



# Hamworthy Purewell VariHeat c

Condensing, Fully Modulating,  
Pre-mix, Gas-Fired,  
Cast Iron Modular boilers

Single Boiler Outputs 70 kW to 180 kW



**Hamworthy**

Heating *at work.*

# Purewell VariHeat c

Condensing Fully Modulating, Pre-mix Gas Fired High Efficiency Cast Iron Modular Boilers

Hamworthy's pedigree in cast iron boiler development, refined over 40 years, stands behind the current range of Purewell VariHeat c boilers. These pre-mix boilers combine cast iron dependability with 21<sup>st</sup> century efficiency. Their highly reliable cast iron heat exchangers are proven tolerant to existing heating circuits and are backed up by Hamworthy's 10-year cast iron warranty.

Purewell VariHeat c boilers are the natural replacement for less efficient atmospheric boilers in existing buildings as well as offering long term peace of mind in new builds. All models comfortably exceed the minimum seasonal efficiency requirements for the Building Regulations Part L 2010 (revised 2013) and ErP directive 2009/125/EC.

The condensing models are the highest efficiency condensing cast iron boilers available in the UK.

Tough, compact, powerful and built to last, the Purewell VariHeat c boiler range is available in five condensing models from 70kW to 180kW.

Purewell VariHeat c boilers feature modern controls and use a LPB (Local Process Bus) communication system. Clip-in modules integrate the boilers and building control systems, with an extensive range of options which include boiler sequencing for up to 16 boilers in a multiple boiler installation.

A range of optional pipework kits are available for 2, 3 or 4 boiler arrangements.

A catalogue of parametric BIM (Building Information Modelling) objects for all Purewell VariHeat c boilers and pipe kits are available to download from our website:

[www.hamworthy-heating.com/bim](http://www.hamworthy-heating.com/bim)

## Options

- Boiler sequencing cascade controller
- Room sensors
- LPB bus communications modules
- Outside air sensor
- DHW cylinder sensor kit
- Pipework header kits
- Site assembly

- Energy saving high efficiency performance
- Models for 11°C ΔT and 20°C ΔT systems
- Robust cast iron heat exchanger
- Proven reliability with 10-year warranty
- Tolerant of older heating systems
- Fully assembled for faster installation
- Close control and accurate load matching
- BIM objects for designers available online

BENEFITS

**Purewell VariHeat c is the highest efficiency cast iron condensing gas boiler available in the UK—the natural replacement for old atmospheric boilers.**



Typical plant room with Purewell VariHeat c highly efficient condensing boilers and a Dorchester DR-FC Evo condensing water heater.

# Specification

## Purewell VariHeat c Natural Gas

Hamworthy have designed the Purewell VariHeat c to retain all the benefits of traditional boilers, but with vastly improved performance to more than meet the efficiency requirements for modern day boilers.

Purewell VariHeat c boilers can be used as single boilers, or as modules in a multiple boiler installation. Each boiler is equipped with a pre-mix down firing burner, cast iron primary heat exchanger and a control panel, all enclosed in a stylish factory fitted casing.

Up to 16 Purewell VariHeat c boilers can be combined, under Merley sequencer control, for up to 2.88 MW output, with up to six boilers sharing a single flue header. Centres are the same as the Purewell and UR predecessors, simplifying replacement.

The boilers are suitable for open vented or pressurised systems and have a maximum working pressure of 6 bar.

### Construction

A down-firing fully modulating gas burner is fitted on top of the primary cast iron heat exchanger and a secondary heat exchanger is positioned in the base of the boiler to maximise heat recovery from the flue gases.

The boilers are delivered fully assembled, but for plant rooms with difficult access, it is a simple task to separate the individual sections for easier handling.

The boilers are finished externally using steel side panels and stylish moulded plastic front and top covers, which give excellent access for servicing and maintenance.

### Performance

Purewell VariHeat c condensing boilers achieve a full load efficiency up to 88.9% gross (98.7% net), whilst at part load the efficiency rises to 98.0% gross (109% net).

This equates to seasonal efficiencies up to 96% gross; easily exceeding the Building Regulations minimum seasonal efficiency requirements of 91% gross or new buildings and 82% for existing buildings.

All boilers achieve European Class 5 performance for NO<sub>x</sub> emissions.

All models comply with the efficiency requirements of the European Union's ErP Energy-Related Products directive.

### 10-Year Guarantee

Hamworthy's confidence in the integrity and durability of the heat exchangers is such that now both the primary cast iron heat exchangers and the secondary condensing heat exchangers carry our full 10-year warranty. For more information see "Warranty" on page 24.

### Easy to Service

Purewell VariHeat c boilers have all major serviceable parts located on the top of the boiler. Quick-to-remove covers provide easy access to the gas valve and fan, and the burner is rigidly secured with just four nuts making disassembly of the gas train and access to the burner for cleaning and servicing fast and efficient. All ignition components can be accessed easily without needing to remove the entire gas train. Cast sections of the primary heat exchanger can be removed individually for inspection or repair. The secondary heat exchanger can be withdrawn from the front of the boiler for fast inspection without dismantling the primary heat exchanger castings.

Other useful features include entirely dry thermowell pockets for all temperature sensors obviating any need for boiler draining for sensor replacement, and a burner back pressure test point is provided to assess burner performance and cleanliness against the original commissioned readings before burner removal.

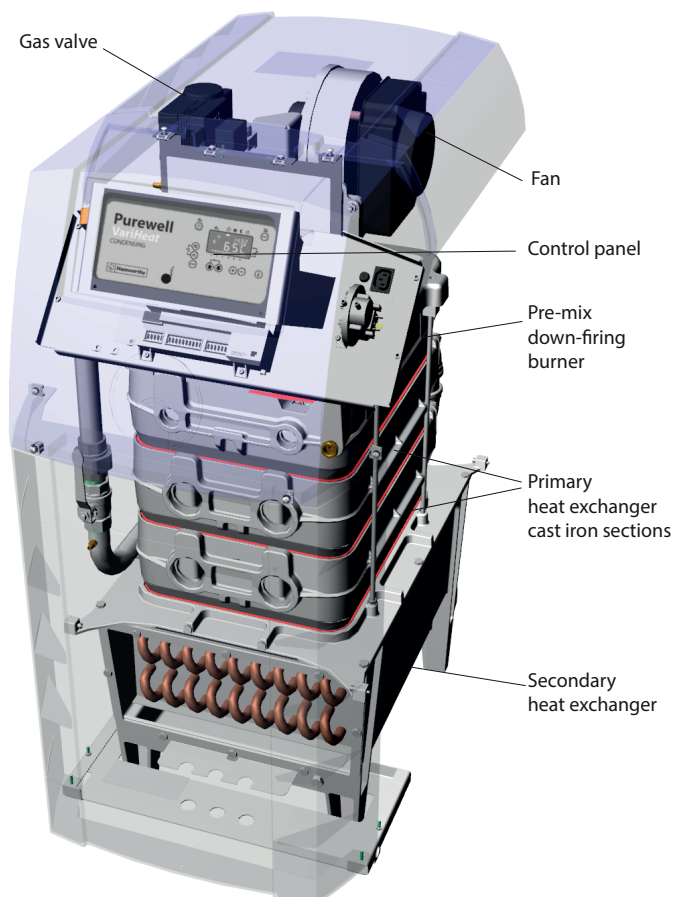

Purewell VariHeat condensing model PV180c—heat exchanger arrangement

# Specification

Purewell VariHeat c  
Natural Gas

## Primary Heat Exchanger

Each boiler has a cast iron primary heat exchanger arranged with horizontal sections, connected at one end only to allow expansion and contraction, retaining a proven horizontal series water flow for even hydraulic distribution.

With waterways typically larger than lightweight wall-mounted boilers, Purewell VariHeat c heat exchangers offer greater resilience to problems associated with older heating circuits.

The primary heat exchanger is fitted on top of the base assembly and encloses the secondary heat exchanger.



Cast iron primary heat exchanger section



Copper/aluminium secondary heat exchanger

## Secondary Heat Exchanger

Condensing performance is achieved by returning the system water through a copper/aluminium composite construction secondary heat exchanger and extracting the latent heat from the flue gases in the base of the boiler. In keeping with most modern high efficiency boilers, the condensing heat exchanger is designed for 20°C ΔT temperature rise, with no minimum flow temperature, maximising the opportunity for condensing performance.

## Operating Pressure

Maximum operating pressure is 6 bar for all models.

## Burner

The Purewell VariHeat c features a fully modulating pre-mix burner control system. An electronic thermostat monitors the boiler operating conditions and automatically adjusts the output to suit these conditions.

The gas/air ratio control system ensures that clean and efficient combustion is maintained throughout the maximum modulation range, down to a minimum of 33% capacity, i.e. a 3.3:1 turndown ratio.

The plaque burner is positioned centrally above the primary heat exchanger and is constructed using a FeCrAl Aconit woven mesh. This design of burner allows for good flame stability at low turndown rates. The woven fibre construction of the burner also results in lower flame temperatures being achieved and lowering NOx emissions.

## Reduced Boiler Weight

Purewell VariHeat c boilers have been reduced in weight significantly, in comparison to traditional atmospheric cast iron boilers, with weights as low as 1.3 kg/kW output. The new casting designs are extremely efficient therefore fewer sections are required to produce the given boiler outputs.

## Flue System

The Purewell VariHeat c is a high efficiency boiler, and like all other high efficiency appliances, requires a water tight flue system that will retain condensate whilst working under positive pressure.

The boiler is fitted with a primary flue connection directly into the base assembly. The connector is fitted as standard with a tri-lip full ring silicone seal which is impervious to water and vapour, ensuring a water tight flue joint. It is suitable for stainless steel flue components in single or twin wall formats.

A fixed draught diverter is not required in the flue system, however, a draught stabiliser is recommended for some installations.

*Refer to pages 20 to 23 for more information about flues.*

## Flue Terminal Location

Purewell VariHeat c condensing boilers will produce condensate due to their high thermal efficiency. The effect of this condensate production is to produce plumbing from the flue terminal, and careful consideration must be given to the location of the flue terminal. Should plumbing be a concern, then the flue system should be designed to discharge at high level so as not to cause a visual intrusion to the building occupants.

# Specification

Purewell VariHeat c  
Natural Gas

## Boiler Thermostats

Purewell VariHeat c boilers are fitted with a manual reset limit thermostat, which has a range of 90-110°C on all models. This will be factory set to 100°C.

Electronic controls allow the flow temperature normally to be set in the range 30°C to 80°C. The electronic temperature control thermostat is preset to regulate the boiler flow temperature up to a maximum setting of 80°C. If higher flow temperatures are required (up to 85°C maximum), please contact Hamworthy.

To accommodate multiple boiler installations, the limit thermostat is adjustable up to a maximum of 110°C, but is factory set at 95°C. Where the boiler control thermostats are to be set higher than 83°C, adequate system pressure must be available either by gravity head or system pressurisation.

*Refer to page 18 for system head calculations in Applications & System Data section.*

The boiler also incorporates a return temperature sensor, which, in conjunction with the flow temperature sensor, governs the modulation set point of the boiler.

## Pipework Kits

To save time and simplify procurement, optional pipework kits are available from Hamworthy. The kits enable multiple boilers to be connected in configurations of 2, 3 or 4 boilers. The pipework kits are factory tested and supplied part-assembled for ease of installation.

Pipework kits include:

- Isolating ball valves for water flow, return and gas inlet connection on each boiler
- Flow and return headers
- Pre-assembled flow and return pipe sub assemblies between boilers and headers.
- Flow line safety relief valve and ½" connection for pressure gauge
- Return line drain valve and ½" connection for expansion vessel in line with BS6644
- Blanking flanges for header ends
- Support legs

## BIM Models

To assist those designing projects using BIM (Building Information Modelling), a catalogue of fully paramatised BIM models is available to download for all Purewell VariHeat c models and pipe kits. For more information please refer to the BIM section on the Hamworthy website:

**[www.hamworthy-heating.com/bim](http://www.hamworthy-heating.com/bim)**

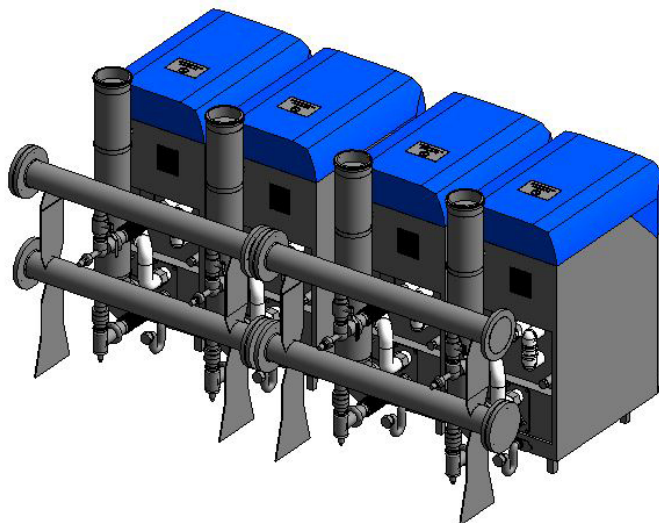

*Rear view of the Purewell VariHeat c BIM model for a 4-boiler arrangement with 2 x 2-boiler pipework kits.*

## Condensing Outputs @ 50/30°C Flow/Return Temperatures

Boiler Model	Min. Output (kW)	Heat Output per Number of Modules Installed (kW)							
		1	2	3	4	5	6	7	8
PV70c	23.3	70	140	210	280	350	420	490	560
PV95c	31.7	95	180	285	380	475	570	665	760
PV110c	36.7	110	220	330	440	550	660	770	880
PV140c	46.7	140	280	420	560	700	840	980	1120
PV180c	60.0	180	360	540	720	900	1080	1260	1440

# Technical Data: c Models

Purewell VariHeat c **Condensing** Boilers  
Performance and General Data Information - Natural Gas

	Boiler Model	PV70c	PV95c	PV110c	PV140c	PV180c
Energy	Building regulations - seasonal efficiency (%) gross	95.35	95.62	95.89	95.74	94.63
	ErP efficiency rating (modules ≤ 70kW only)	A	n/a	n/a	n/a	n/a
	Boiler output 80/60°C	kW 63.5 Btu/hr x 1000 217	86.3 294	99.8 341	134.4 448	172.8 590
	Boiler output 50/30°C	kW 70 Btu/hr x 1000 239	95 324	110 375	140 478	180 614
	Boiler input (gross) Maximum	kW 72.2 Btu/hr x 1000 246	98.4 336	115.0 392	151.3 516	194.6 664
	Boiler input (net) Maximum	kW 65.0 Btu/hr x 1000 222	88.6 302	103.5 353	136.3 465	175.2 598
	Boiler output Minimum 80/60°C	kW 21.2 Btu/hr x 1000 72	28.8 98	33.3 113	44.8 153	57.6 197
	Boiler output Minimum 50/30°C	kW 20.3 Btu/hr x 1000 69	27.6 94	31.9 109	40.6 138	52.2 178
Water	Water content litres	8			11	
	System design flow rate @ 20°C ΔT rise l/s	0.8	1.1	1.3	1.7	2.1
	Water side pressure loss @ 20°C ΔT rise` mbar	32	52	72	134	221
	System design flow rate @ 11°C ΔT rise l/s	1.5	2.1	2.4	3.0	3.9
	Water side pressure loss @ 11°C ΔT rise mbar	96	176	244	442	731
	Maximum water pressure barg	6				
Gas	Gas flow rate natural gas (G20) - maximum m³/hr	6.88	9.37	10.96	14.42	18.54
	Nominal inlet pressure natural gas (G20) - maximum mbar	20				
	Maximum gas inlet pressure natural gas (G20) mbar	25				
Flue	Approx. flue gas volume @ 15°C, 9.3–9.8% CO <sub>2</sub> @ N.T.P m³/hr	86.13	117.37	137.16	180.53	232.12
	Approx. flue gas temperature @ 50/30°C °C	40		45	50	50
	Approx. flue gas temperature @ 80/60°C °C	60		65	70	75
	Pressure at boiler flue spigot @full load Pa mbar	100 1.0				
	Dry NO <sub>x</sub> emission (0% excess oxygen, dry air free) European Class 5 mg/kWh	18.5	57.5	69.2	57.0	67.1
Connection	Water flow/return connections inches	R2"				
	Gas inlet connection pipe thread size inches	R1"				
	Nominal flue diameter (I/D) mm	150				
Electrics	Electrical supply	230 V 1 Ph 50Hz				
	Power consumption @maximum boiler modulation W	94.3			207	
	Start current Amp	0.54			0.60	
	Run current Amp	0.41			0.90	
	Approx shipping weight kg	170			230	
	Noise emission @1 m and @maximum boiler modulation Max dB (A)	53			65	

# Dimensional Details: c Models

Purewell VariHeat c

## Boilers Without Pipe Kits

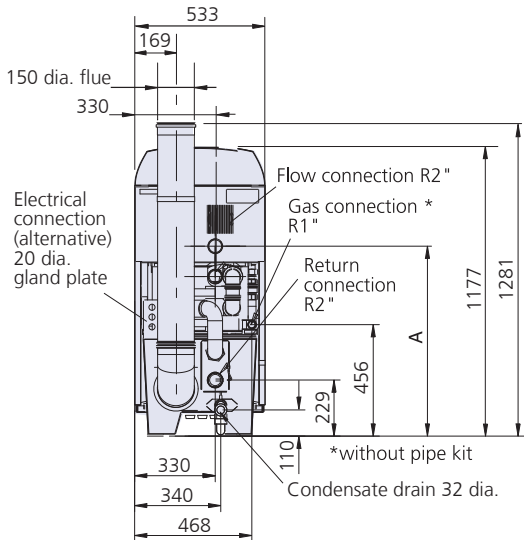

Dimensions mm	Ref.	PV70c, PV95c, PV110c	PV140c, PV180c
Flow connection	A	647	775

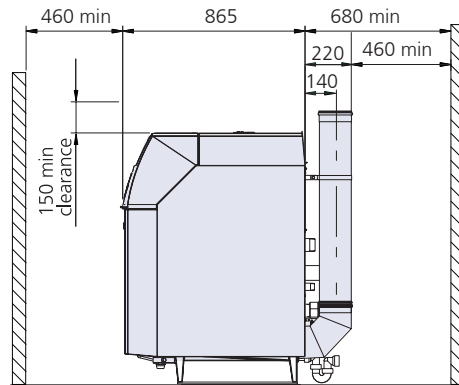

Note: Do not run trunking or pipework across the top of the boiler. Access is required top and front for servicing.

## Boilers With Pipe Kits

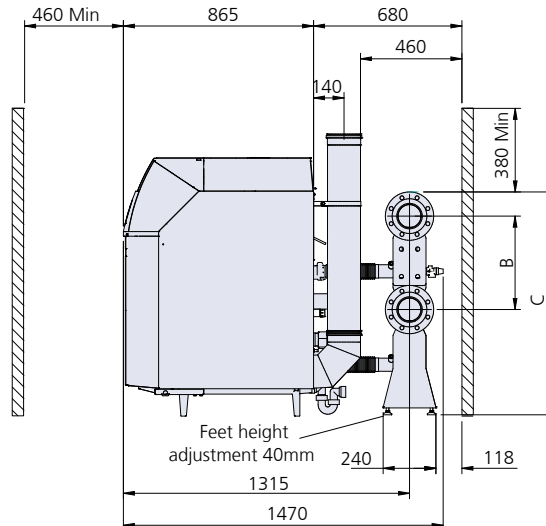
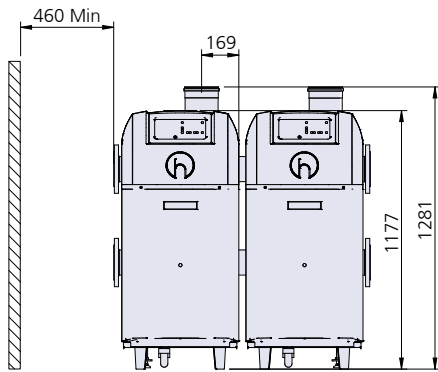

There are two distinct pipe kits available:  
 - a two-boiler pipe kit, and  
 - a three-boiler pipe kit.  
 Each flow and return pipe is a single continuous length of pipe, with flanged connections at each end, and sized for the width of two boilers or three boilers accordingly.  
 Two blank flanges are also included in each kit.  
 For a four-boiler arrangement, use two 2-boiler pipe kits together.  
 Electrical trunking may be run in front of the boiler at floor level, below the front cover. (not HHL supply).

For 4 boilers use 2 x 2-boiler pipe kit, width 2336\*

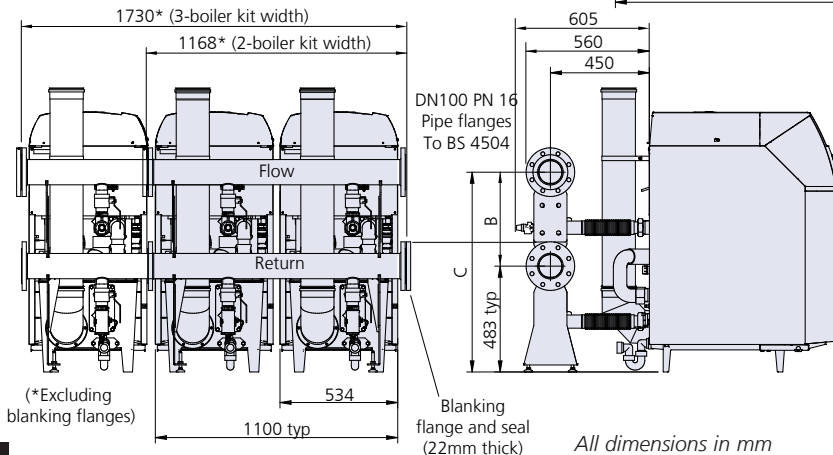

All dimensions in mm

Dimensions mm	Ref.	PV70c, PV95c, PV110c	PV140c, PV180c
Flow/return centres	B	425	550
Header Flow connection	C	908	1033
Pipe flange to BS4504		DN100 (4") NB PNI6	

# Controls Overview

## Purewell VariHeat c

Purewell VariHeat c boilers can be installed in a wide variety of configurations, from single boiler stand alone units to multiple boilers controlled locally or by a building management system. The controls package is extremely versatile and can be tailored to meet the exact needs of the heating system.

### Integrated Systems

The full benefits of installing high efficiency boilers can only be realised if the heating system is equipped with appropriate controls, that integrate the boiler and the other system components, to create a cohesive solution. For that reason, the Purewell VariHeat c range of boilers incorporate a control system that is easy to integrate and communicates with the leading building management system protocols. The microprocessor based boiler control system (LMU) accommodates clip-in modules providing relay contacts for remote alarm and signalling, for external control and LPB bus communications, for use with the boiler cascade controller for multiple boiler installations.



*Clip-in modules on the LMU*

The Purewell VariHeat c boiler incorporates a number of inbuilt and optional controls features that enable the end user to achieve desired operational mode whilst maintaining the optimum efficiency of the system.

The controls are housed within a fabricated steel enclosure, and each module fascia features a visual display allowing the user to monitor the current operating status of the boiler. The panel also displays comprehensive fault code information in the unlikely event of a boiler lockout.

### Volt Free Contacts

All Purewell VariHeat c modules are fitted with a multi-function clip-in module to provide volt free contacts as standard. Remote alarm signalling is provided for a general fault alarm and boiler normal run indication.

### 0-10 Volt DC Analog Input

The standard multi-function clip-in module also provides a 0-10 volt DC analog signal interface to control the modulation level of the burner, or to set the flow temperature set point. The 0-10 volt signal can be used for remote connection of the boilers to a Building Management System, (BMS) to enable modulating control remotely.

### LPB Bus Communications Module

The optional LPB bus communication clip-in kit is used to connect the boiler LMU control unit to the optional cascade sequence control module. Each boiler in a modular installation requires a clip-in LPB bus communications module to communicate with the cascade controller.

### Outside Air Temperature Sensor

Purewell VariHeat c boilers can be supplied with an optional outside temperature sensor to exploit the full functionality of the boiler controls and enable direct temperature compensation on the boiler, maximising the condensing operating conditions. The outside temperature sensor is to be used in conjunction with the optional cascade control module.

When fitted with an outside temperature sensor, the boiler's own thermostat is overridden and the flow temperature is controlled as a function of external temperature conditions. The flow temperature is adjusted according to a preset heating curve built into the standard boiler controls. This slope can be adjusted to suit the needs of individual systems by for example using a steeper slope on underfloor heating systems.

### Programmable Room Sensor

An optional combined room sensor and digital programmer can be connected to the boiler to provide both temperature control of ambient conditions and to programme up to three daily periods for heating or hot water.

Note: An outside sensor must be used when using the room sensor and programmer. Separate ambient temperatures can be set for each time period with an override facility, enabling the user to switch the system either on or off at their request. The programmer will display the current system operating parameters and also indicate any boiler fault conditions that might occur.

### Frost Protection

The boiler control system features a two stage frost protection system. When the boiler is not operating, the frost protection system fires the boiler to maintain a minimum water temperature, to prevent freezing of the heating system water.

Additionally, if an external temperature sensor is connected, the circulation pump will be run intermittently when the outside temperature falls below 1.5°C.

### Cascade Control Module

For use with multiple boilers, the optional cascade controller can sequence up to 16 modules. The controller is supplied with two clip-in LPB bus communications modules as part of the standard cascade kit, and for each additional boiler in the modular installation, further clip-in LPB bus communications modules must be ordered separately, i.e. a four-modules installation with a cascade control kit requires two additional LPB modules.



# Control Details

## Purewell VariHeat c, Single Boiler Installations

On Purewell VariHeat c boilers, the control options for single boilers are different to those for multiple boilers.

*Please refer to page 10 for controls on multiple boilers.*

All controls functions are managed via the 'boiler management unit' Siemens LMU64. Using a combination of options, the level of control is expandable for up to 2 heating circuits and 1 domestic hot water cylinder.

A circulation pump overrun timer is incorporated within the boiler LMU.

### Programmable Room Sensor

A single boiler Purewell VariHeat c system can be fitted with a single programmable room sensor, which should be located in the first heating zone. This room thermostat allows heating circuit management to be based on both the internal and external air temperature. The boiler will manage the heating circuit pump via a contactor according to the program requirements of the programmable room unit.

Features:

- Individual 7-day program with auto summer / winter hour change for heating circuit 1, heating circuit 2 and DHW
- 4 periods per day per time program
- Constant or variable temperature flow
- Compensated flow temperature based on external and room air temperatures
- Building frost protection based on room air temperature
- Summer shutdown based on outside air temperature
- Holiday period with frost protection
- Reduced temperature, night set back for non-occupancy hours
- Pump kick for pumps controlled from boiler
- Programme lock to prevent tampering with different access levels for OEM/Engineer/User
- Individual temperature settings for each zone

To achieve full functionality an outside air sensor must be fitted.

## Options for a Single Boiler Only

- **Programmable room sensor (QAA73)**
- **Outside air sensor (QAC34)**
- **2<sup>nd</sup> heating circuit clip-in relay kit (AGU2.500)**
- **DHW cylinder Sensor Kit (QAZ21)**

### Outside Air Sensor

An optional outside air temperature sensor may be wired directly to the boiler to exploit the direct weather compensation functionality of the boiler controls. This sensor may be connected to the control scheme and should ideally be positioned on an external wall with northerly aspect.

### 2<sup>nd</sup> Heating Circuit Clip-in Relay Kit

To control a second heating circuit, an additional clip-in relay kit is required for fitting directly to LMU. The kit comprises a relay and water temperature sensor complete with pocket.

This kit provides outputs for a pump and mixing valve:

- Mixing valve allows second heating circuit to operate at a different temperature set-point to heating circuit 1.
- Second heating circuit should operate at the same or lower temperature than circuit 1, e.g. underfloor heating.
- Programmed via QAA73 programmable room sensor
- Compensated flow based on outside air temp and using a curve separate to that of heating circuit 1 owing to mixing valve
- Frost protection based on water temperature in second heating circuit

For the second heating circuit, the boiler will manage the circuit pump and/or mixing valve via contactors, according to the program requirements of the programmable room sensor and the water temperature sensor.

Only one programmable room sensor may be connected, therefore the second heating circuit management is derived from time control and external air temperature measurement.

### DHW Cylinder Sensor Kit

This kit is for a domestic hot water (DHW) circuit directly controlled from the boiler, but programmed via the QAA73 programmable room sensor, and features:

- Immersion sensor complete with pocket
- DHW cylinder sensor and pump output directly from boiler LMU
- Frost protection based on stored water temperature
- Reduced storage temperature for non-occupancy hours
- Anti-Legionella function

For the DHW cylinder circuit, the boiler will manage the primary coil pump according to the program requirements of the programmable room unit and the DHW cylinder sensor.

# Control Details

## Purewell VariHeat c, Multiple Boiler Installations

On Purewell VariHeat c boilers, the control options for multiple boilers are different to those for single boilers.

*Please refer to page 9 for controls on a single boiler.*

### Sequence Controller LPB Bus

For use with multiple boilers, the optional Merley sequence controller can control up to 16 modules. The boilers and sequence controller communicate via the LPB bus.

Merley is the latest generation boiler sequence controller for multiple boiler installations. Using the Siemens controls platform, Hamworthy boilers can be controlled to share the load between boiler modules to maximise efficiency and system performance.



*Merley wall mounted sequence controller*

As a standalone device with autonomous control of the boilers, the controller can be extended to sequence control the boilers and also to manage a complete heating circuit as well as a domestic hot water (DHW) cylinder.

A range of room and external air temperature sensors, including wireless options, ensures comfort levels within the building are maintained.

When integrated with a building management system (BMS), the Merley operates only as a boiler sequence controller, receiving the required operating temperature from the building management system via a 0 to 10volt analog signal.

Each sequence control system is supplied with a smart digital interface display allowing the user to monitor the current operating status of the boilers, and also the building where the Merley is used to control a heating zone and hot water cylinder.

*Full details of the Merley sequence controller are provided in publication, 500002524, available to download at [www.hamworthy-heating.com](http://www.hamworthy-heating.com), or to request a printed copy, Tel: 0845 450 2865.*

## Options for Multiple Module Boilers

- **Boiler sequencing cascade controller**
- **LPB bus communications clip-in module**
- **Choice of room sensors**
- **External air sensor**
- **Hard wired or wireless controls**
- **DHW Cylinder Sensor Kit**

The Merley boiler sequence controller can be supplied within a dedicated housing for wall mounting or as a loose kit for integrating within a plant room control panel.

### Wall Mounted Controller

Merley sequence controllers are available factory assembled within a robust steel enclosure suitable for wall mounting, with the digital interface display pre-mounted to the housing door.

The sequence controller is mounted to a DIN rail attached to the panel back plate assembly, with electrical trunking to simplify routing for site cables to the appropriate wiring terminations.

A cable gland plate is located on the underside of the control panel with 6 loose cable glands supplied for fitting on site.

### Loose Kit Controller

For installations where the sequence controller will be integrated within an existing or new plant room control panel, the Merley sequence controller can be supplied in loose kit form.

A suitable space must be allocated within the plant room control panel for mounting the sequence controller to the back plate and for mounting the digital display to the control panel door.

### Boiler Sequence Control Strategies

The Merley sequence controller can be configured to sequence boilers in traditional cascade mode or in unison mode.

#### Cascade Control

Steps a boiler module on at its lowest rate and then modulates it to its maximum rate, before switching on the next boiler module to match the system load. Maintains the lowest number of boiler modules in operation for a given heat load.

This control strategy is particularly suited to boilers operating in constant temperature systems where there is no great efficiency advantage to be gained from operating boilers at part load.

#### Unison Control

Steps each boiler module on in turn at its lowest rate, and then modulates all boiler modules simultaneously to higher rates to match the system load. This method of sequencing can offer higher operating efficiencies, taking advantage of the higher part load efficiencies available at low firing rates.

This control strategy is particularly suited to condensing boilers operating in variable temperature systems where low water temperatures and part load boiler operation allows optimum boiler operating efficiency to be achieved.



# Boiler Efficiency and Load Matching

Purewell VariHeat c, Multiple Boiler Installations with Merley sequencer

## Improved Efficiencies

Hamworthy's expertise in cast iron boiler development over the last forty years is reflected in the continual improvement in boiler efficiency, with consequent benefits to our customers: reduced fuel consumption, lower running costs, and a corresponding reduction in carbon emissions.

Compare today's condensing Purewell VariHeat models' excellent seasonal efficiency of around 95% with our early atmospheric boilers: UR and Purewell On/Off models (~78%) or Purewell Classic High/Low models (~82%); a saving of up to 17%.

But that is only part of the story. Seasonal efficiency is calculated using part load and full load data, per individual boiler. The overall efficiency of a multiple boiler plant depends also on how close its total output can be controlled to match the load profile of the building.

## Improved Load Matching

Consider a system designed for a peak demand of 280kW using four 70kW boilers as shown in the example diagram. With old UR On/Off boilers, the plant's maximum turndown ratio is 4:1 i.e. the plant can be turned down from 280kW to 70kW, but in this case, only in 70kW increments.

If there is an off-peak demand period, requiring ideally a constant 95kW of power to maintain a heating circuit at a set temperature, then to meet that demand two boilers would need to run together. The plant would then produce 140kW, i.e. 45kW more than necessary. When the required temperature is attained, one boiler would turn off, the other would continue alone at 70kW until the circuit temperature dropped to a point which triggered the second boiler to turn on again.

With Purewell Classic High/Low boilers the plant's turn-down ratio increases to 8:1. For a demand of 95kW, one boiler could fire at full load (70kW) and another at part load (35kW) producing 105kW.

This arrangement gets closer to the required 95kW than with the UR boilers but still uses 10kW more power than necessary. With both On/Off and High/Low boiler examples, the plant's output power switches between levels above and below the ideal power required, reducing the overall plant efficiency and increasing wear and tear on the second boiler as it would need to cycle on and off.

## Benefits: Purewell VariHeat + Merley

- Closer matching of plant output to load
- Greater plant turn-down ratios
- Higher overall efficiencies
- Greater fuel savings and reduced emissions
- Opportunity to reduce total number of boilers

Using today's fully modulating 70kW Purewell VariHeat boilers with individual turndown ratios of 3.3:1 the example plant's turndown ratio increases to around 12:1. Moreover, due to infinite fan speed burner control, the incremental adjustment of each boiler's output power between part and full load settings is far more precise. Under Merley sequencer programmable control, this allows for very accurate load matching and so greater overall plant efficiency.

The example 95kW requirement could be achieved by firing two, three or four Purewell VariHeat boilers and modulating these together to achieve 95kW. Four boilers running at 23.75kW each would be the most fuel efficient as boilers run most efficiently at lowest loads. Alternatively, one boiler could be run at 70kW (full load) and a second boiler could be run at 25kW (near fully modulated).

Choosing the right control strategies for multiple boiler plant e.g. using unison or cascade operation, boiler firing order, etc., will depend on the application priorities and the planned maintenance regime. Please contact Hamworthy for guidance in making the right choices for your application.

Improved turn-down ratios and typically higher outputs of Purewell VariHeat models over their predecessors, as well as better insulated buildings, means that when refurbishing a plant room there is often the opportunity to reduce the total number of boilers used and so make savings in the overall cost of purchase and installation. With fewer units to maintain, reductions in annual maintenance can also be realised. In the example below, 3 x 95kW Purewell VariHeat models are shown as an alternative to 4 x 70kW models; together these satisfy the 280kW peak load requirement in the example system, and the 95kW off-peak load could be met by a single boiler module.

### Existing Multiple Boiler Plant

UR boilers	High Fire or Off	4 x 70kW On/Off atmospheric boilers (UR)				Max. plant output 280kW Min. plant output 70kW Seasonal efficiency ~78% Turndown ratio 4:1
		70kW Off	70kW Off	70kW Off	70kW Off	

Purewell and Purewell Classic boilers	High Fire or Low Fire	4 x 70kW High/Low atmospheric boilers (Purewell Classic)				Max. plant output 280kW Min. plant output 35kW Seasonal efficiency ~82% Turndown ratio 8:1
		70kW 35kW	70kW 35kW	70kW 35kW	70kW 35kW	

### Purewell VariHeat Refurbishment

One-for-one swap out	High Fire to Low Fire	4 x 70kW Fully modulating condensing boilers (Purewell VariHeat)				Max. plant output 280kW Min. plant output 21kW Seasonal efficiency ~95% Turndown ratio 12.1:1
		70kW 21kW	70kW 21kW	70kW 21kW	70kW 21kW	

or Reduce no. of boilers	High Fire to Low Fire	3 x 95kW fully modulating condensing boilers (Purewell VariHeat)			Max. plant output 285kW Min. plant output 28kW Seasonal efficiency ~95% Turndown ratio 9.1:1
		95kW 28kW	95kW 28kW	95kW 28kW	

# Hydraulic Schemes 1 & 2

Purewell VariHeat c Boilers  
Hydraulic Schematics

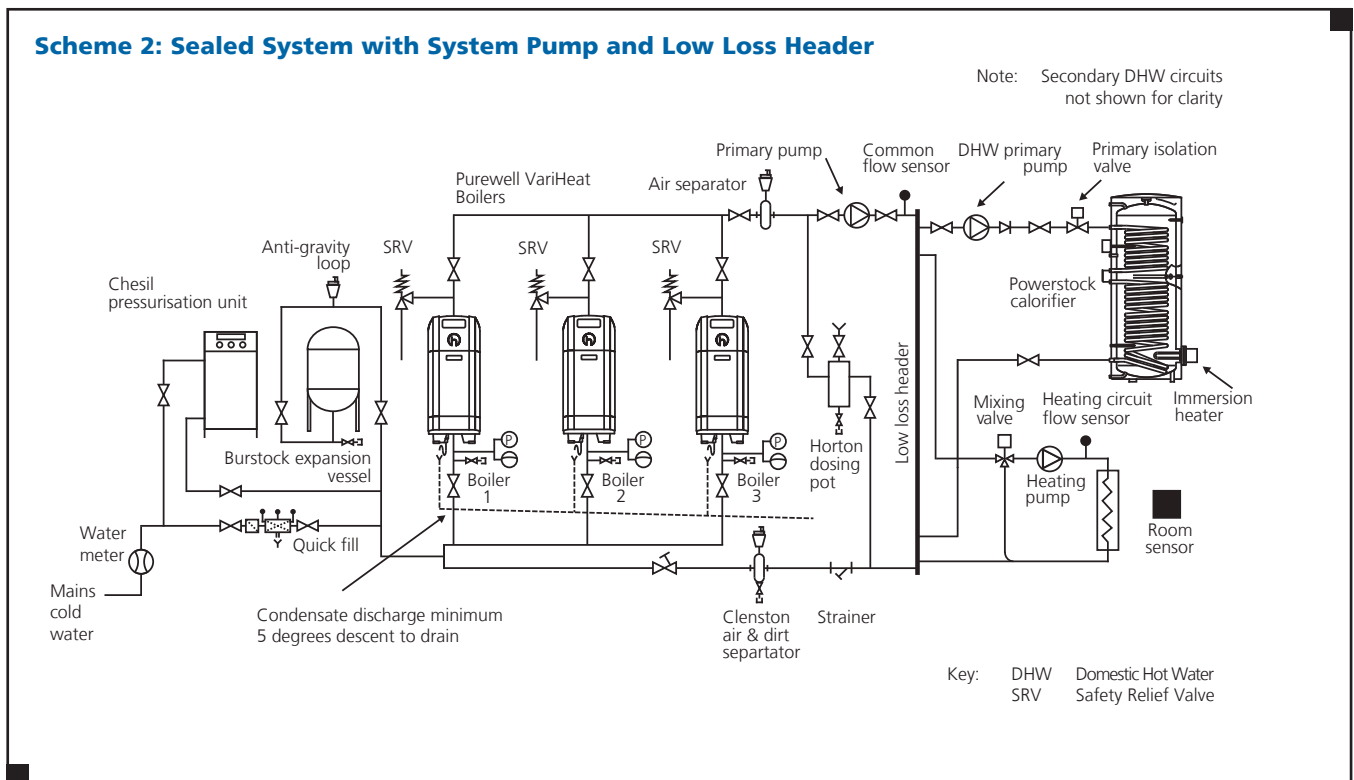
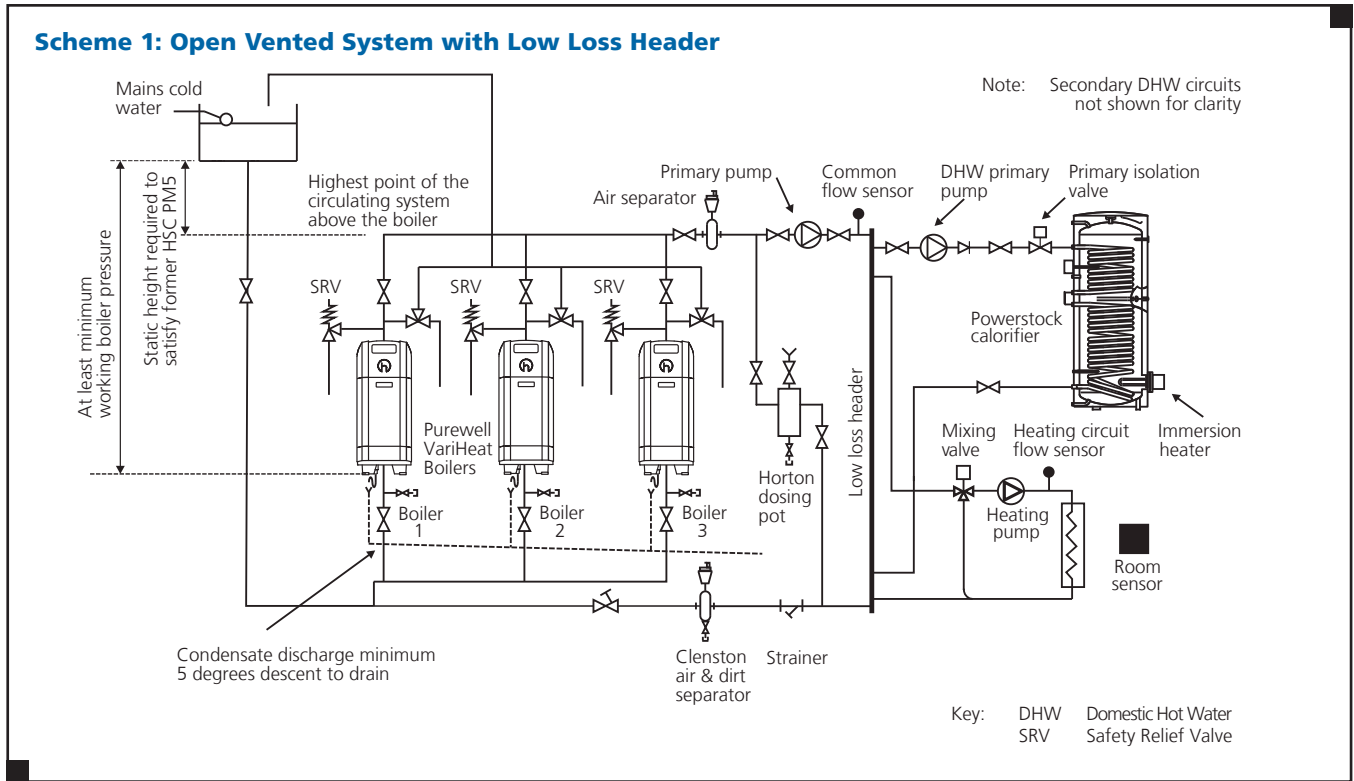

These schematics are available to download at [www.hamworthy-heating.com](http://www.hamworthy-heating.com)

# Hydraulic Schemes 3 & 4

Purewell VariHeat c Boilers  
Hydraulic Schematics

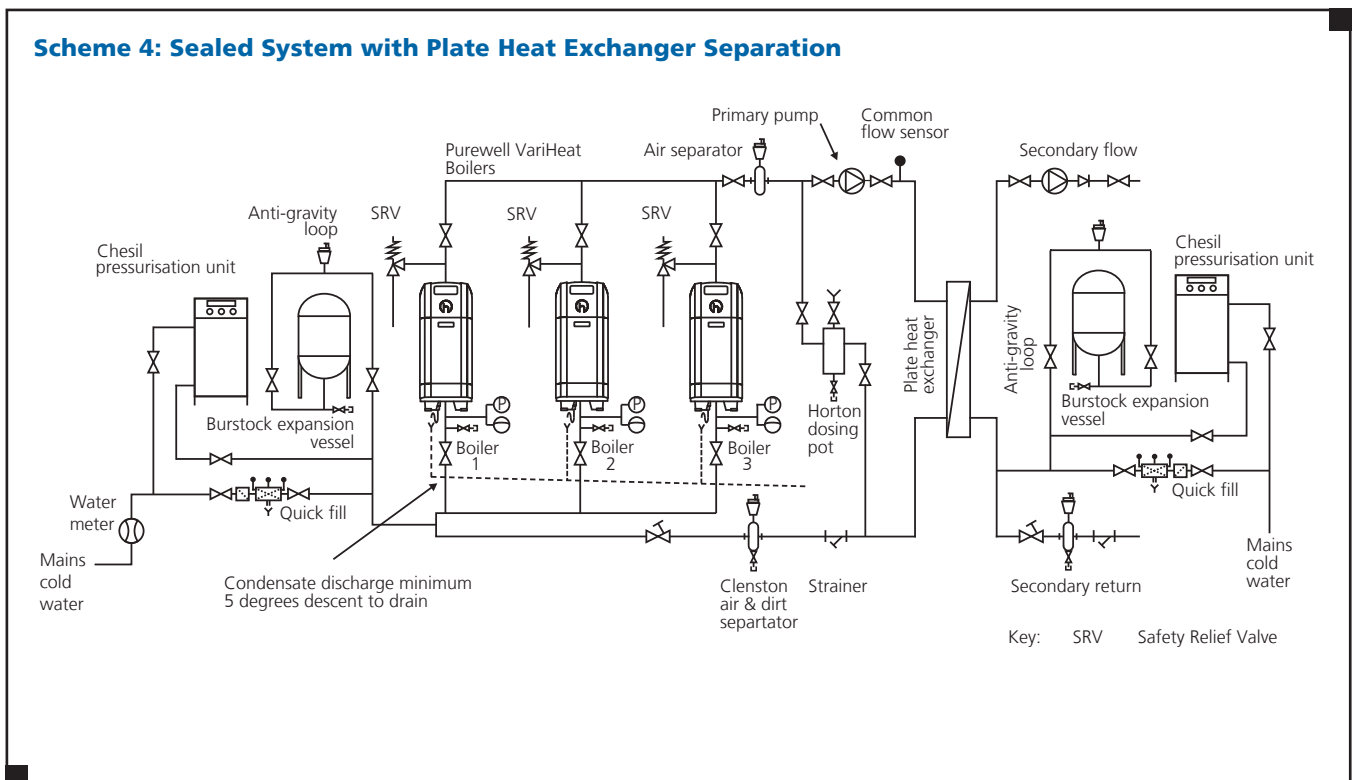
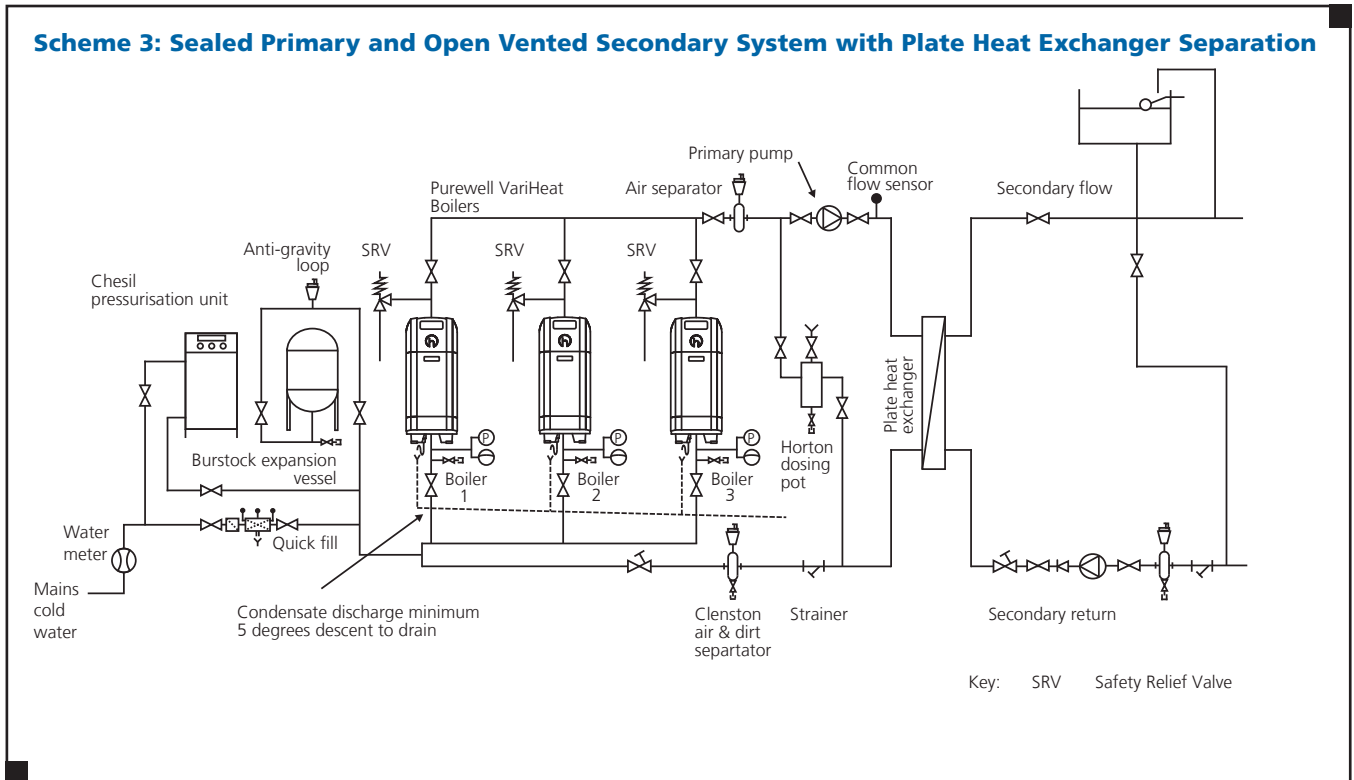

These schematics are available to download at [www.hamworthy-heating.com](http://www.hamworthy-heating.com)

# Hydraulic Schemes 5 & 6

Purewell VariHeat c Boilers  
Hydraulic Schematics

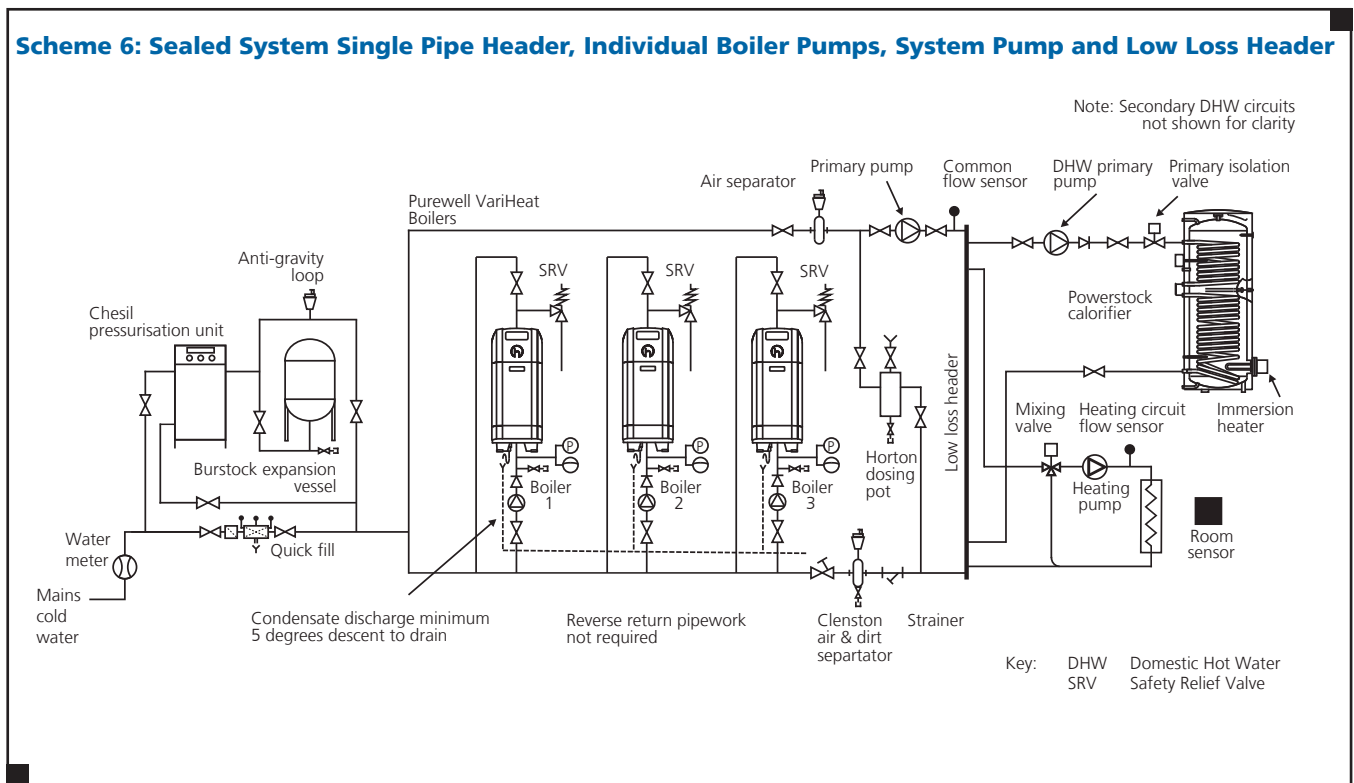
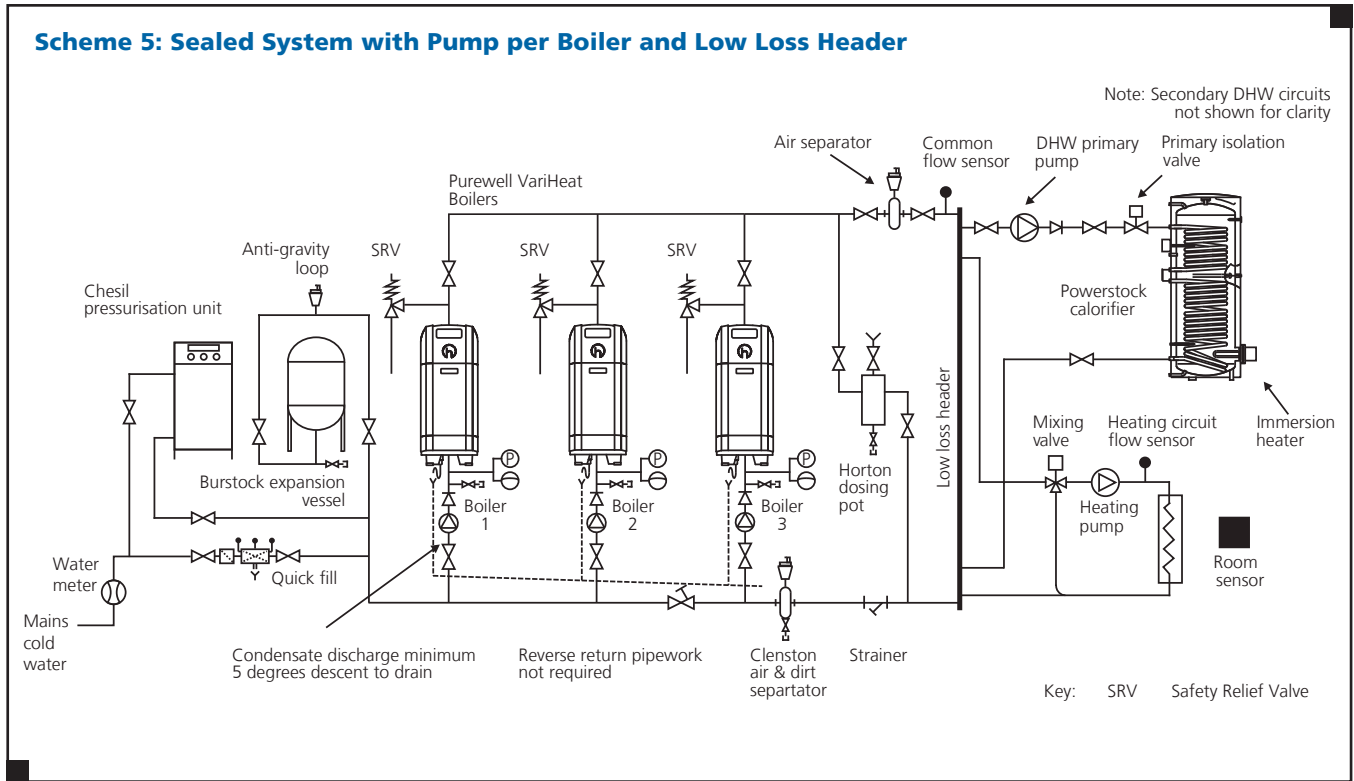

These schematics are available to download at [www.hamworthy-heating.com](http://www.hamworthy-heating.com)

# Hydraulic Schemes 7 & 8

Purewell VariHeat c Boilers  
Hydraulic Schematics

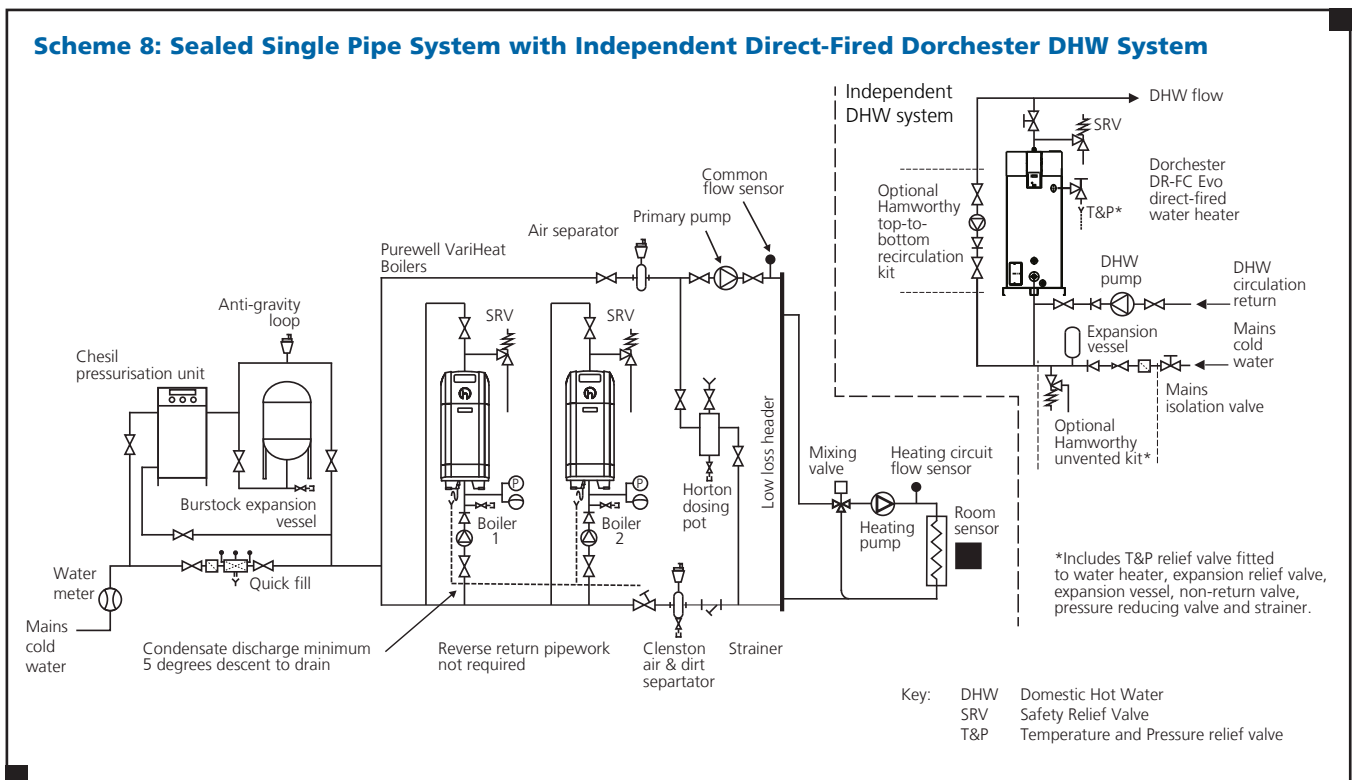
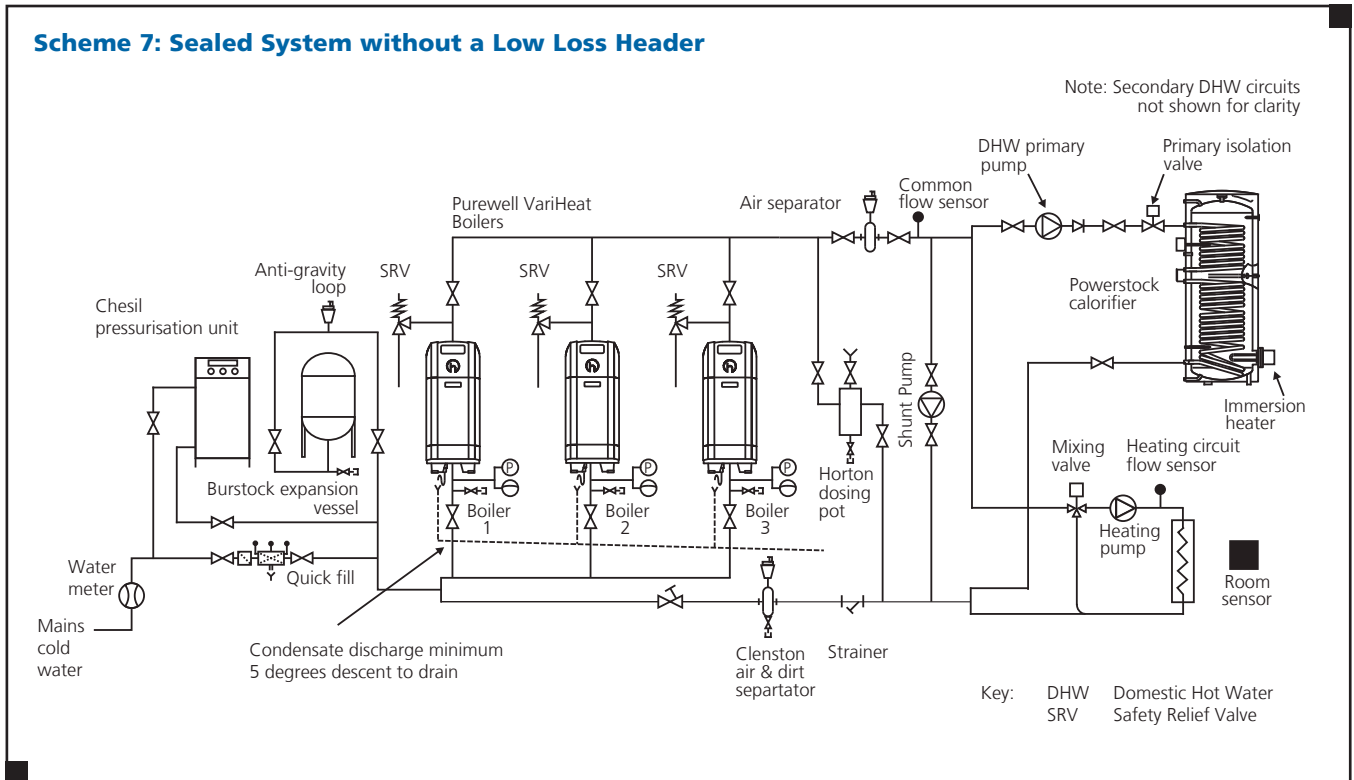

These schematics are available to download at [www.hamworthy-heating.com](http://www.hamworthy-heating.com)

# Application & System Data

## Purewell VariHeat c Boilers

The installation of the boiler MUST be in accordance with the relevant requirements of the Gas Safety Regulations, Building Regulations, IET Regulations and the bylaws of the local water undertaking. It should also be in accordance with any relevant requirements of the local gas region and local authority and the relevant recommendations of the documents below.

The following British Standard Codes of Practice and Regulations have relevant recommendations regarding the installation of Purewell VariHeat c boilers.

### British Standards

**BS 5440** Part 1 Installation and maintenance of flues for gas appliances of rated input not exceeding 70kW net.

**BS 5440** Part 2 Installation and maintenance of ventilation for gas appliances of rated input not exceeding 70kW net.

**BS EN ISO 4126-1** Safety devices for protection against excessive pressure. Safety valves.

**BS 6798** Installation of gas appliances rated input not exceeding 70kW net.

**BS 6644** Installation of Gas Fired Hot Water Boilers, 70kW to 1.8MW net input.

**BS 6700** Design, installation, testing and maintenance of services supplying water for domestic use.

**BS EN 806-2** Specification for installations inside buildings conveying water for human consumption – Part 2: Design.

**BS 6880** Part 1,2 & 3 Code of practice for low temperature hot water heating systems of output greater than 45kW.

**BS 6891** Installation of low pressure gas pipework up to 35mm (R1¼) in domestic premises.

**BS 7074** Part 1 Application, selection and installation of expansion vessels and ancillary equipment for sealed water systems.

Part 2 Code of practice for low and medium temperature hot water systems.

**BS 7671** Requirements for electrical installations. IET Wiring Regulations. Seventeenth edition.

### I. Gas E. Publications

**IGE/UP/1** Soundness testing and purging of industrial and commercial gas installations.

**IGE/UP/1A** Soundness testing and direct purging of small low pressure industrial and commercial natural gas installations.

**IGE/UP/2** Gas installation pipework, boosters and compressors in industrial and commercial premises.

**IGE/UP/10** Installation of gas appliances in industrial and commercial premises, Part 1 Flued appliances.

### Health and Safety Executive (HSE)

**INDG436** Safe management of industrial steam and hot water boilers.

**BG01** Guidance on Safe Operation of Boilers.

### CIBSE Publications

**CIBSE Guide B** Heating, ventilating, air conditioning and refrigeration.

**CIBSE Guide H** Building Control Systems

**CIBSE Guide Energy Efficiency in Buildings**

**CIBSE Commissioning Code B: 2002**

### UK Legislation, UK Public General Acts

**Clean Air Act 1993**

### Location

The location chosen for the boiler must permit the provision of a satisfactory flue system and an adequate air supply. The location must also provide adequate space for servicing and air circulation around each unit.

This includes any electrical trunking laid along the floor and to the appliance.

Any combustible material adjacent to the boiler and the flue system must be so placed or shielded to ensure that its temperature does not exceed 65°C. Further details regarding boiler location are given in BS 6644 & BS 5440 part 2.

Purewell VariHeat c boilers should be positioned on a level non-combustible surface that is capable of supporting the boiler weight when filled with water, plus any ancillary equipment. Adequate space should be allowed for installation and servicing. *Refer to dimensional drawings on pages 7 for more details.*

### Adequate Water Flow

The Purewell VariHeat c boiler is designed as a quick response, low water content unit to run continuously with minimal operating problems. Care should be taken in the initial design and layout, having due regard for adequate water flow through the boilers, and the influence of the control system. Hamworthy strongly recommend that Purewell VariHeat c boilers are installed using the primary circuit design to ensure adequate water flow regardless of secondary circuit operating conditions. Refer to technical data tables for minimum water flow requirements.

The control system and valves, where fitted, should be regulated to avoid lower flows occurring. Condensing models are designed to operate with systems operating at 20°C differential temperatures and with no minimum design return temperature, although the return temperature will be limited by frost protection settings. Increased flow rates may be used for lower temperature differentials with due regard for the increased pressure loss through the boiler.



# Application & System Data

## Purewell VariHeat c Boilers

### Water Systems

Purewell VariHeat c boilers are suitable for both open vented or sealed pressurised systems. For safe operation (formerly a requirement of the Health and Safety Document PM5; now withdrawn) Hamworthy recommends sealed systems to have a fuel supply cut off in the event of low and high pressure conditions. Hamworthy also recommend for sealed systems to use a Chesil pressurisation unit with correctly sized Burstock expansion vessels.

In multiple boiler installations, the flow and return headers should be connected in a "reverse return" arrangement, i.e. the water flow in each header follows the same direction, thus providing equal flow through each boiler. This also ensures that the pressure loss across any number of boilers will never be greater than the head loss across one boilers plus local pipework losses.

### System Feed Water Quality

If the boiler feed water has a high degree of hardness, it is recommended that the water be treated to prevent precipitation of scale or sludge in the boiler water passageways. Details of additives can be obtained from any reliable manufacturer of water treatment products or the local water authority.

### Open Vent Pipe and Cold Feed Pipe Data

Boiler	Open Vent Size	Cold Feed Size
<60kW	25mm (1 in)	19mm (3/4 in)
60kW - 150kW	32mm (1 1/4 in)	25mm (1 in)
150kW - 300kW	38mm (1 1/2 in)	32mm (1 1/4 in)
300kW - 600kW	50mm (2 in)	38mm (1 1/2 in)
601kW - 800kW	65mm (2 1/2 in)	50mm (2 in)
801kW - 1200kW	80mm (3 in)	50mm (2 in)

### Condensate Discharge

The condensate drains safely into the base assembly and a 32 mm diameter drain connection is provided, to run in standard plastic waste piping.

This condensate drain must be connected to a suitable drainage system, typically as shown below. The material should be a suitable PVC plastic system with sealed joints to prevent the escape of condensate.

Drain traps and an open tundish should be incorporated into the design, and the pipework given appropriate protection from physical damage.

The pipework should be installed with at least a 3 degrees fall (approximately 50mm per metre).

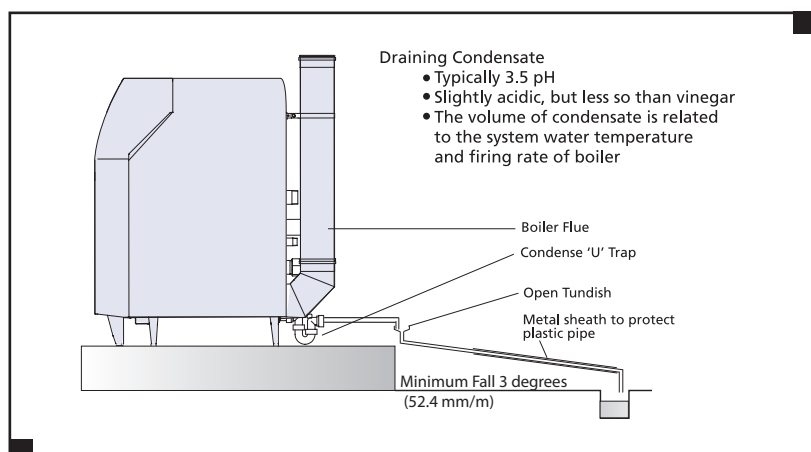

### Pressure Relief Valve

Each boiler, or in the case of a modular installation, each bank of boilers, must be fitted with a pressure relief valve to BS EN ISO 4126-1, and sized as shown in BS 6644.

Hamworthy can supply Purewell VariHeat c pipe kits which have isolation valves for each boiler, to enable individual boilers to be shut down from the system. The pipe kit includes a three-port valve on the flow connection for each boiler, enabling a single safety valve to be fitted to the connection on the header pipework. Safety valves are not included.

Where these pipe kits are not used, each boiler must be fitted with a safety valve in the flow pipework, positioned before any other valve in the system. BS 6644 provides comprehensive information for the selection and location of safety valves and attention is drawn to the higher capacity requirements of safety valves for pressurised hot water systems.

### Boiler and System Pumps

Purewell VariHeat c boilers should be installed within a primary circuit having a dedicated primary pump and low loss header to ensure adequate boiler flow regardless of flow conditions within the secondary circuits.

With modern, high efficiency, low water content boilers such as the Purewell VariHeat c the hydraulic resistance is likely to be higher than traditional atmospheric boilers that might be being replaced and so increasing the pumping effort required.

To assist with reducing energy costs associated with running the boiler circulating pumps, it is possible to configure a dedicated pump to each boiler module in a multiple boiler arrangement, and to control each pump directly by its associated boiler's controller. Then the electrical energy required for the pumps to circulate water through the boilers will be a function of the number of pumps that are switched on, which in turn is determined by the number of boilers the system controller signals to run at any given time.

Due to seasonal variations in load it is unlikely that all boilers will be required to fire together except in exceptionally cold winters, and so such a pump scheme will result in lower pumping requirements and associated energy costs for the majority of the season.

Pump energy usage is a factor to consider when deciding on unison or cascade boiler control when using the Merley sequence controller.

# Application & System Data

## Purewell VariHeat c Boilers, System Head

### Guidance (based on PM5\* Health and Safety Executive)

PM5\* stated that "hot water boilers should have an automatic control apparatus to cut off fuel to the burners of gas fired plant when the water at or near the boiler flow outlet rises to a predetermined temperature. This should provide a margin of at least 17°C below the temperature of saturated steam corresponding to the pressure at the highest point of the circulation system above the boiler." To comply with this recommendation, the minimum system pressure is dependant on system design flow temperatures and in the case of modular installations, the temperature rise across each module.

**\*Note PM5 has now been withdrawn however Hamworthy still recommend this guidance as sound engineering practice.**

### Single Installations

The minimum pressure must be equal to the gauge pressure equivalent to the saturated steam temperature obtained by adding 17°C to the required boiler flow temperature.

The highest point of the circulation system above the boiler should never be less than 2 m (6.5 ft)

Required flow temperature	90°C
Safety margin	17°C
Equivalent saturated steam temperature	107°C

From steam tables the corresponding gauge pressure is **0.3 bar (3.0m head of water)**.

### Modular Installations

The minimum pressure should be equal to the gauge pressure equivalent to the saturated steam temperature. This is obtained by adding 17°C to the sum of the required mixed flow temperature plus the temperature rise across the modules.

System $\Delta T$	11°C	20°C
Required mixed flow temperature	82°C	80°C
Temperature rise across modules at minimum flow rate	11°C	20°C
Safety margin	17°C	17°C
Equivalent saturated steam temperature	110°C	117°C

From steam tables the corresponding gauge pressure at 11°C  $\Delta T$  is **0.43 bar (4.4m head of water)**.

From steam tables the corresponding gauge pressure at 20°C  $\Delta T$  is **0.80 bar (8.2m head of water)**

### Air Supply and Ventilation

An adequate supply of fresh air for combustion and ventilation must be provided in accordance with BS 6644.

The air supply should be achieved using:

- Natural ventilation supplying air with a low level opening and discharge through a smaller sized high level opening.
- A fan to supply air to low level with natural discharge through a high level opening.

A fan to supply air to low level and discharged by means of a fan at a high level.

**Note: Fans must be selected such that a negative pressure is not created in the boiler house relative to outside air pressure.**

The air supplied for boiler house ventilation should be such that the maximum temperatures within the boiler house are as follows:

- At floor level: 25°C (or 100 mm above the floor level)
- At mid level: 32°C (1.5 m above floor level)
- At ceiling level: 40°C (or 100 mm below ceiling level)

**The air supply should be free from contamination such as building dust. To avoid unnecessary cleaning and servicing, we recommend that the boilers are not fired whilst building work is being undertaken.**

Where natural ventilation is used suitable permanent openings at low level and high level connected directly to the outside air should be provided. These openings must be fitted with grilles that cannot be blocked or flooded.

The free area of the grilles should be as follows:

- At low level (Inlet) 4 cm<sup>2</sup> per kW of net heat input.
- At high level (Outlet) 2 cm<sup>2</sup> per kW of net heat input.

Where a boiler installation is to operate throughout the summer months, then additional ventilation allowances are required. Refer to BS 6644 for more detailed information.

### The Building Regulations 2010 (Revised 2013)

**Approved Document L2A 2013 Edition: Conservation of fuel and power (New buildings other than dwellings), Approved Document L2B 2010 Edition: Conservation of fuel and power (Existing buildings, other than dwellings), and Amendments to the Approved Documents, November 2013.**

These regulations came into force 6th April 2014. Compliance with the latest regulations now requires a whole building approach to reduction in carbon emissions. The 2013 edition requires the use of heat generating plant as detailed in the supporting 2nd tier guide - Non Domestic Building Services Compliance Guide: 2013 Edition.

### Minimum Gross Boiler Seasonal Efficiencies

For natural gas single boiler installations, gross boiler seasonal efficiency\* must be no less than 91% for new builds (82% for existing builds). For multiple boiler installations, the combined boilers' gross seasonal efficiency must not be less than 86% for new builds (82% for existing builds), with no individual boiler at less than 82% for new builds or existing builds; however for existing builds only, the installation's effective boiler seasonal efficiency\*\* must be no less than 84%.

**All Purewell VariHeat c models exceed these minimum efficiency requirements; individual boiler figures can be found on page 6.**

\*Gross boiler seasonal efficiency is calculated using a combination of part load and full load gross operating efficiencies.

\*\*Effective boiler seasonal efficiency = gross boiler seasonal efficiency plus any applicable heating efficiency percentage credits (up to max. 4%).

# Wiring Diagram

## Purewell VariHeat c Boilers

### Electrical Connections

The following electrical connections are provided on each module:

- Supply live neutral and earth
- Supply input for boiler fault and normal run signals
- Boiler fault alarm system signal output
- Boiler normal run signal output
- 0-10V analogue control signal input
- Remote on/off control input
- Boiler shunt pump output
- Safety interlock circuit input

There is a gland plate fitted to the front of the boiler, at floor level, to accept cables for power supply and controls. A single terminal rail is fitted inside the front cover, and all external connections are made to this terminal rail. The plug-in terminal rail facilitates easy removal for improving access during servicing and maintenance.

### Power Supply

An independent isolator and fused 230V, 50Hz, single phase electrical supply is recommended for each boiler as its permanent supply. For normal operation (not maintenance), boiler enable/disable should be carried out via the remote On/Off function which requires a volt-free contact (not HHL supply) to make a connection between terminals 15 and 16. Making the connection switches on the internal 24V DC control circuit which enables the boiler. Breaking the connection switches off the control circuit and disables the boiler.

Wiring external to the boiler must be installed in accordance with IET Regulations and any local regulations which apply. Wiring must be completed in heat resistant 3-core cable, (size 1.0mm<sup>2</sup> c.s.a.). Fascia fuse rating is 2 amp. External fuses should be 6 amp for all single boiler sizes.

To prevent drawings excessive current (>1 amp) through the boiler control panel, it is recommended that pumps are connected via contactors.

### Terminal Rail Connections

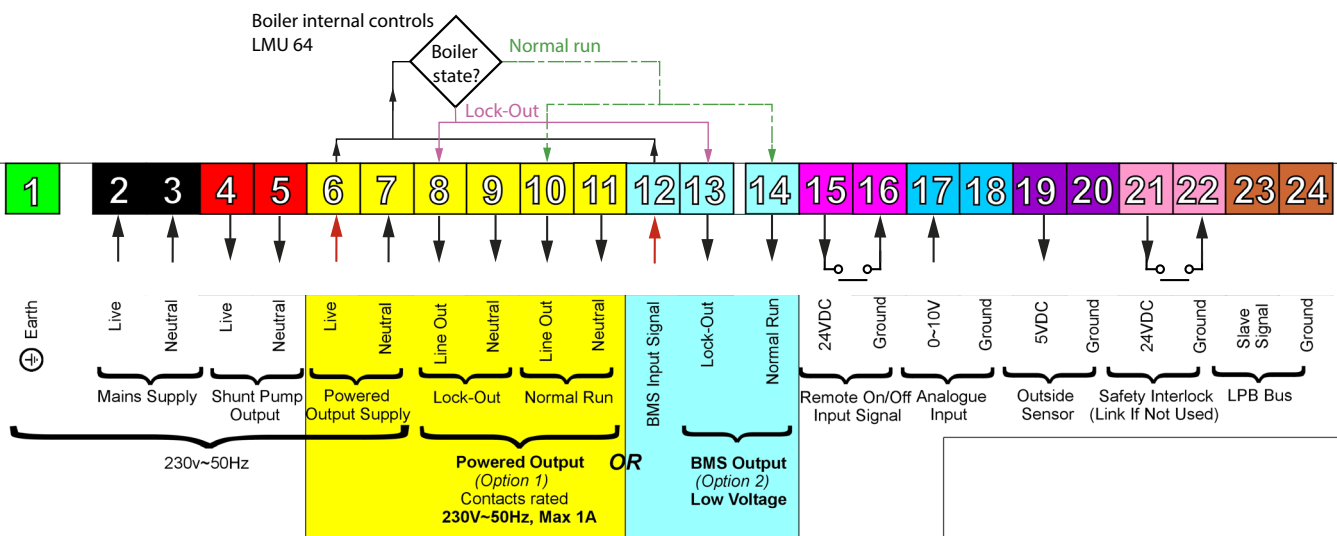

The Purewell VariHeat provides options for powering the Lock-Out/Normal Run indication function by a choice of either 230VAC mains or by a low voltage (typically 12V or 24V DC) supplied from a BMS. A choice of two sets of terminals, Option 1 (yellow terminals 6 to 11) for 230V AC mains signalling and Option 2 (pale blue terminals 12 to 14) for Low Voltage signalling have been provided for the Lock-Out/Normal run indication function. Note that only one option may be selected.

#### Caution:

**For safe operation, ensure to connect to only one of these sets of terminals, and not to both. This will prevent any risk of mains voltages being unintentionally supplied via the "Low Voltage" outputs to any BMS equipment connected to them.**

#### Notes:

1. Shunt pump output terminals 4 and 5 should be connected via contactors to the separately supplied pumps.
2. Any voltage applied on linked terminals 6 or 12 will return, via the LMU 64, the same voltage as output on terminals 8 and 13 with the boiler in lockout state, or will produce the same voltage as the output on terminals 10 and 14 with the boiler in normal run state.
3. For remote On/Off control, a volt free contact is required across terminals 15 and 16, and must be closed to enable the boiler.
4. Terminal 17 is for an analog 0-10V input signal from the BMS to remotely control the boiler modulation.
5. Terminal 19 is a 5V DC output for an outside sensor.
6. Terminals 21 and 22 are for safety interlock circuit. An open circuit across terminals 21 and 22 will disable the boiler.
7. A link must be fitted between terminals 21 and 22 if safety interlock circuit is not used.

# Flue System

## Purewell VariHeat c Boilers

Purewell VariHeat c boilers have a pressurised flue outlet, enabling a flue installation to be designed using smaller diameter components.

The following points should be noted:

- A suction condition within the flue is not required, so it may be possible to achieve a lower chimney terminal height, however all installations must still comply with the requirements of the Clean Air Act 1993 Chimney Memorandum, BS 6644, BS 5440 and IGE/UP/10.
- Draught conditions: the flue must be designed to limit the maximum suction at the flue connection to the boiler to be no greater than 0.3 mbar negative (boilers cold), and with all boilers firing no greater than 1.0 mbar negative.
- Where draught conditions at the boiler flue outlet are likely to become negative it is recommended that a draught stabiliser is fitted.
- All models have a fan assisted burner to overcome boiler resistance. The flue must be designed taking into account that there may be a positive pressure generated by the boiler combustion fan. The maximum permitted positive pressures (flue resistance) at the flue connection to the boiler are given in the tables to the right.
- The flue system must be capable of handling saturated flue gases in a positive pressure system.
- The boilers may be flued individually.  
*Details of flue sizes and length of flue runs are shown on page 21.*
- Multiple boilers may be installed using a common flue header. The maximum number of boilers firing into a common chimney is 8. Please consult with our flue technical team for further advice.
- The flue components should be fully welded and CE marked for positive pressure application.
- The flue system must be self supporting and facilitate access for cleaning and maintenance near the boiler connection.

- When designing the flue system, care must be taken to ensure that any condensate that may form within the system can be drained safely to a suitable waste point, and that the flue and drain materials are resistant to the corrosive effect of condensate.
- Purewell VariHeat c boilers are suitable for installation in a balanced compartment in accordance with the requirements of BS 6644.
- Due to low flue gas temperatures (50°C to 70°C in condensing models), condensation will occur in the flue, therefore flue materials must be non-corrosive and use fully sealing joints.
- Twin-walled flue construction is recommended, with adequate facilities provided for draining the flue condensate.

Purewell VariHeat c Condensing Boilers			
Model	Units	Max. Positive Flue Back Pressure at Boiler Spigot	Max. Negative Flue Pressure (Suction) at Boiler Spigot
All models	mbar	+1.0	-0.3 (cold), -1.0 (hot)

### Flues from Hamworthy

Hamworthy can provide modular, twin-walled, insulated, fully welded flue solutions, optimised for condensing Purewell VariHeat c boiler applications, via our flue partners Midtherm. These feature:

- Leak proof, high temperature seals, impervious to water and vapour.
- Premium grade stainless steel construction for inner and outer walls.
- 87 degree elbows and tees to ensure condensate drains effectively.
- Fast, push-fit/clamped assemblies with no need for additional sealants.
- Fire resistant - 4 hour fire rated.
- Stress-free thermal expansion.
- CE mark accredited to meet 2005 legislation.

### Design & Install or Supply Only

Hamworthy works in partnership with Midtherm Engineering to provide a comprehensive flue design and installation package for all of the Purewell VariHeat c boilers.

Alternatively, flue components can be provided on a supply only basis for the contractor to install.

*Please contact your Hamworthy Area Sales Manager about your bespoke flue requirements, and get peace of mind on your next project.*

**Tel: 0845 450 2865**

**Email: [sales@hamworthy-heating.com](mailto:sales@hamworthy-heating.com)**

# Flue System

## Purewell VariHeat c Boilers

### Flue System for Individually Flued Single Boilers Only

The table below provides a guide to the maximum flue length allowed for each boiler using 150mm diameter components on condensing boilers.

Purewell VariHeat c Condensing Boilers				
Boiler Model	Flue Diameter (mm)	Maximum Flue Length (m)	Equivalent Length (m)	
			90° Elbow	45° Elbow
PV70c	150	131	2.1	1.6
PV95c	150	114	2.2	1.7
PV110c	150	114	2.2	1.7
PV140c	150	79	2.3	1.8
PV180c	150	57	2.3	1.8

### Open Flue

Purewell VariHeat c boilers are designed for type B23 open flue systems.

**Type B:** An appliance intended to be connected to a flue that evacuates the products of combustion to the outside of the room containing the appliance. The combustion air is drawn directly from the room.

**Type B2:** A type B appliance without a draught diverter.

**Type B23:** A type B2 appliance incorporating a fan upstream of the combustion chamber/heat exchanger.

For details of the full range of classifications refer to BSI publication PD CEN/TR 1749:2005.

### Equivalent Length Components

The maximum flue length is the sum of all the vertical and horizontal sections plus the equivalent lengths of all the 90 degree and 45 degree elbows.

The tables opposite provide details of the flue system maximum lengths, and the equivalent lengths for the elbows.

### Flue System for Multiple Boilers

Multiple boilers may be installed using a common flue header. For more information see pages 22 and 23.

#### NOTES

1. As the flue coupled to these boilers will be pressurised and the flue gases wet, leading to running condensation within the flue, it is important that the flue components used are fully sealed and resistant to the aggression of condensate.

2. 45° and 90° bends are based on slow radius components. Alternative bends and components will have differing performance characteristics leading to a final performance that does not match the details in the charts.

3. If the flue system intended is not covered by the details in the charts then contact Hamworthy Heating for advice. Using different sizes and diameters will effect the equivalent length of flue that may be used.

# Flue System

## Multiple Purewell VariHeat c Boilers

### Multiple Boilers—Same Appliance Type

Up to 6 Purewell VariHeat c boilers may be installed using a common flue header, with a maximum of 8 boilers connecting to the same riser or chimney via two or more flue headers. The use of swept connections from appliances into a common flue is recommended to assist the flow of gases into the common flue in the intended direction of flow. The combustion circuit within Purewell VariHeat c boilers is equipped with a back flow prevention device to prevent flue gases spilling through non-firing appliances.

### Flue Liners

When replacing atmospheric boilers and appliances it may be possible to install a continuous stainless steel flue liner within the existing flue riser as atmospheric appliances typically have larger diameter flue systems than modern fan-assisted pre-mix appliances. At the base of any such flue riser the flue header is likely to require replacement using fully sealed and pressure tight components that have been sized for the installed appliances.

### Flue System Condensate Discharge

In addition to the boiler condensate discharge it is important that the flue header and riser used with multiple appliance systems is drained independently to avoid flue condensate draining back through the boiler or other appliance.

### Draught Generated by Flue Risers

- 4 Pa (0.04 mbar) per metre height @140°C
- 2 Pa (0.02 mbar) per metre height @80°C
- 0 Pa (0.00 mbar) per metre height @40°C

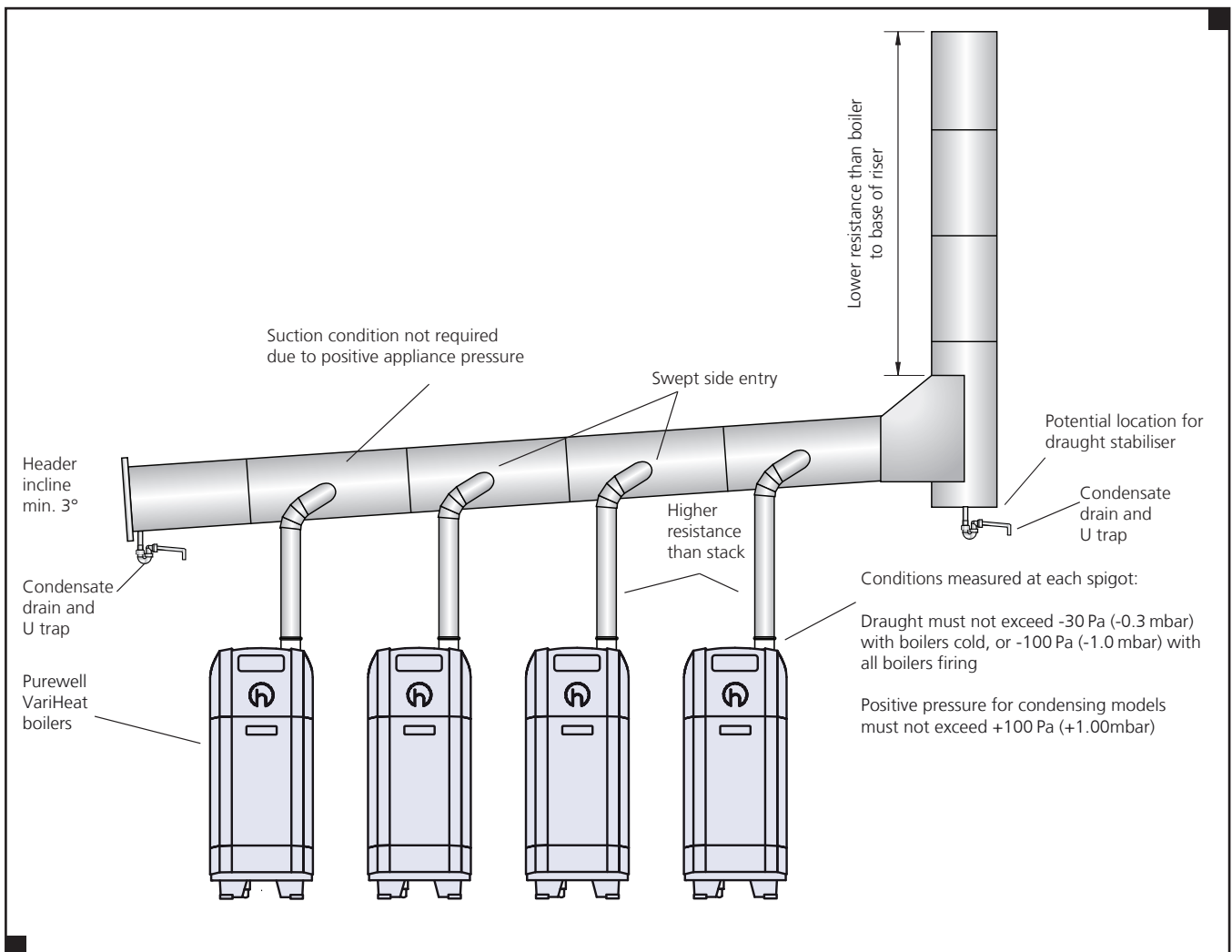

Multiple Purewell VariHeat c boilers sharing a common flue header and B23 type flue

# Flue System

## Multiple Mixed Appliances

### Multiple Appliances—Different Appliance Types

Purewell VariHeat c boilers may be installed with other similar pre-mix pressurised flue outlet appliances in a common flue header arrangement with natural draught flue systems. Where Purewell VariHeat c boilers are installed in a combined flue system along with direct-fired water heaters (high efficiency or condensing, pre-mix pressurised flue outlet type), then it is recommended to locate the water heaters closest to the flue riser for improved summer operation when the boilers may be switched off.

Please note that the Hamworthy Dorchester range of direct-fired water heaters must not be installed on a common flue header; each Dorchester direct-fired water heater must be individually flued.

Where additional appliances are not equipped with a back flow prevention device, it is imperative that flue systems for multiple and mixed appliances are designed to prevent the possibility of flue gases spilling through to non-firing appliances.

### Draught Stabilisers

Flue systems on both multiple boiler and mixed appliance type systems should be designed to prevent negative flue draught conditions from occurring at the boiler/appliance flue outlets or within the flue header for multiple appliances.

Where this is not possible and negative flue draught conditions are likely to occur then draught stabilisers should be fitted. In the case of a multiple boiler flue system this should be fitted at the base of the main flue riser to help prevent negative flue conditions within the flue header.

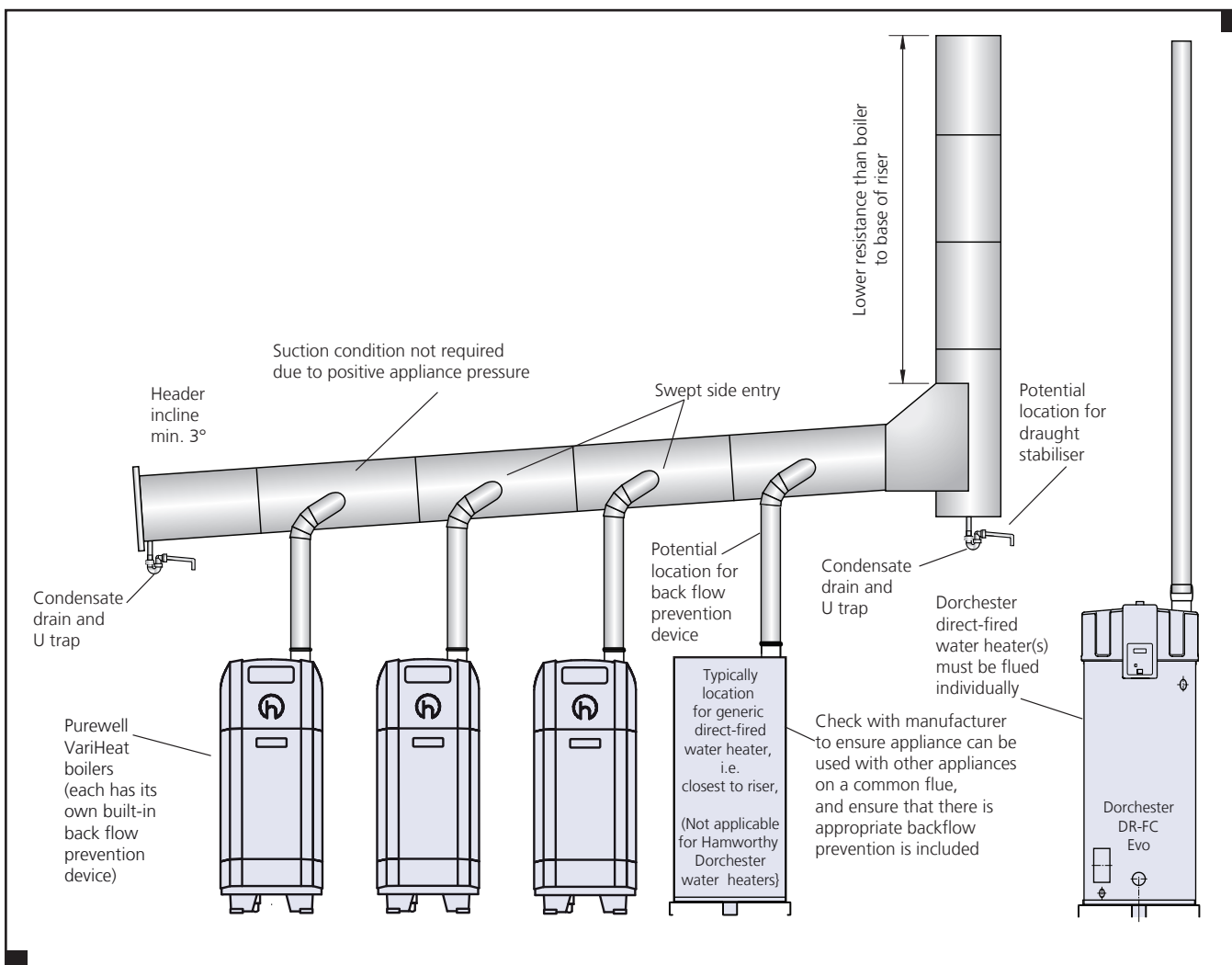

Multiple Purewell VariHeat c boilers and generic water heater sharing a common flue header and B23 type flue

# Services and Warranty

## Purewell VariHeat c Boilers

### Delivery

Each boiler is despatched fully assembled and factory tested with the casing and control panel fitted. The boiler base has been designed to accept a pallet truck allowing easy manoeuvrability. The assembly is protected with cardboard edging and shrink wrapped for transportation.

The primary flue pipe is supplied separately for fitting on site.

All Hamworthy products are delivered to site on a tail-lift vehicle, and deliveries are closely co-ordinated with the customer, to suit the site construction programme. Standard delivery is to ground level from the tail-lift of the vehicle.

To enquire about special delivery services, please contact our customer services team.

### Commissioning and Service

Hamworthy Heating strongly recommend that all boilers are commissioned by our service department. On completion, Hamworthy will issue a boiler log book which will provide details of the initial operating settings. The log book should be used to record any future maintenance and service work.

Hamworthy can also provide a range of servicing options tailored to your requirements.

*For more information on commissioning and service please contact Hamworthy Heating Service Department: Tel 0845 450 2866.*

### Warranty

Both the primary and secondary heat exchangers carry a 10 years' parts-only warranty from date of despatch, or, if hamworthy commission the boilers and carry out commissioning within 6 months of the delivery date, then they carry a 10 years' parts and labour warranty from the date of commissioning.

All other Purewell VariHeat c parts carry Hamworthy's standard two years' warranty (except for consumables in line with our Terms and Conditions), and where the product is commissioned by Hamworthy service engineers, then the two years' warranty covers parts and labour from date of commissioning if the commissioning is carried out within 6 months of delivery date.

In offering flexible solutions for after sales support, Hamworthy can tailor packages to suit individual customer requirements, many of which include extended warranty benefits.

Full details of warranty terms and conditions are available on request.





# Heating and Sustainable Hot Water

Purewell VariHeat c Boilers with Renewables

## Why Choose Hamworthy?

Hamworthy has extensive knowledge and over 40 years of experience of heating and hot water systems for commercial buildings, including supply of gas fired boilers for peak-load delivery alongside solar hot water systems. We can advise on the optimum boiler, water heater and solar thermal equipment selection for each project .

Whether it's for a new build, or for a refurbishment project, and whatever level of solar thermal integration is required for the building, we have the knowledge and expertise to help

guide you through every stage of the process, from site survey to completed installation and on-going support.

For advice on making the right choice for your heating and hot water systems, talk to Hamworthy.

**Tel: 0845 450 2865**

**Email: [sales@hamworthy-heating.com](mailto:sales@hamworthy-heating.com)**

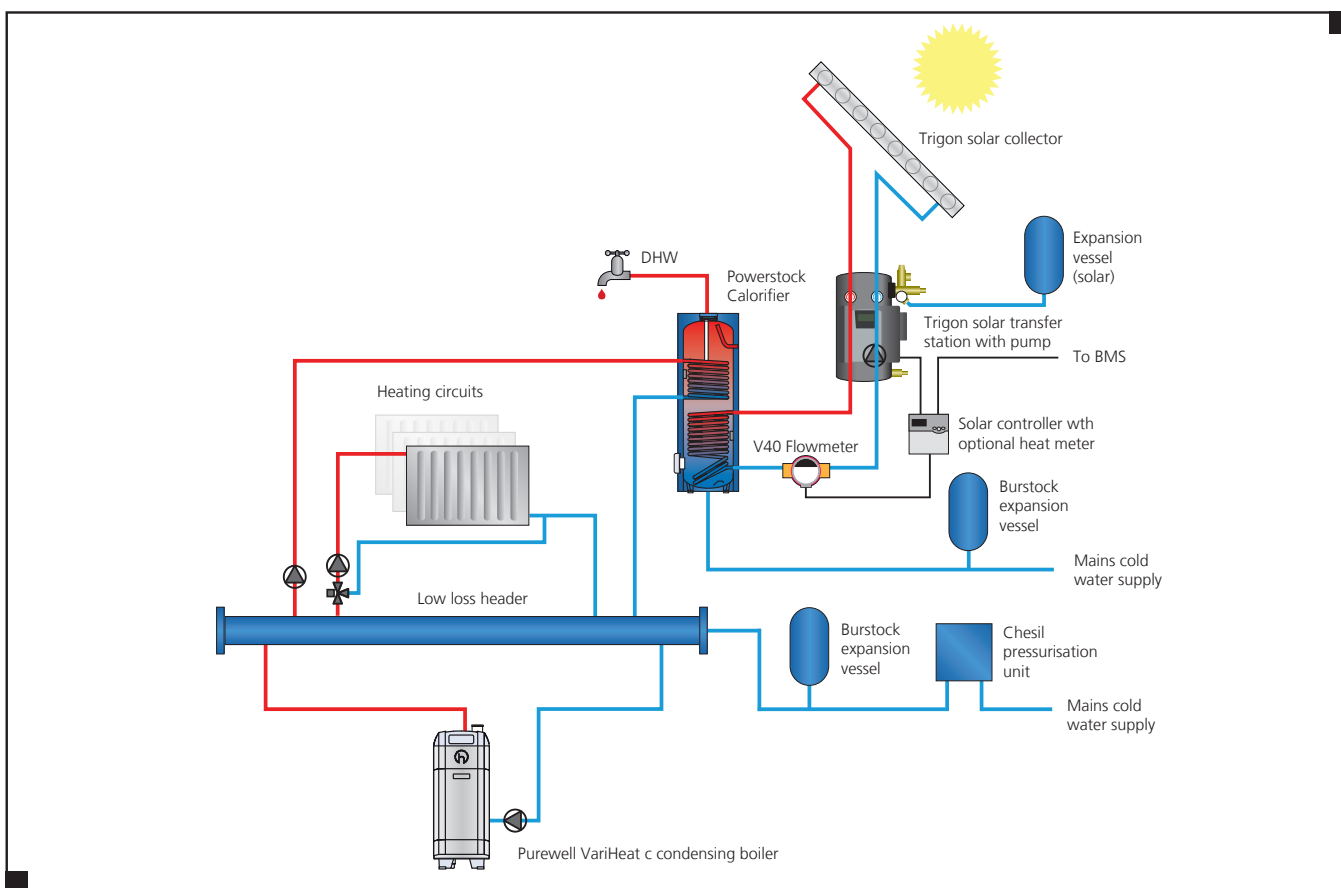

*Hamworthy renewable capability with combined heating and DHW systems.*

A typical Hamworthy combined traditional and renewable solution for heating and DHW is shown above in simplified form, and includes the following main items of equipment:

**Heating System:** Purewell VariHeat c condensing boiler, low loss header, Chesil pressurisation unit and Burstock expansion vessel.

**Renewable and/or Indirect-fired DHW System:**

Field of solar collectors feeding a twin-coil calorifier via a solar transfer station and controller, with flowmeter and separate expansion vessels for the solar and DHW circuits.

Additional valves and safety equipment required for the unvented Purewell VariHeat c and Powerstock hydraulic circuits are not shown for clarity. An unvented kit is available for the Powerstock which includes a Burstock expansion vessel and the necessary valves.

For Hamworthy boilers and direct-fired water heaters, Hamworthy can supply a comprehensive range of flue solutions to complete the package.

# Case Study

Project: Purewell VariHeat c Upgrade at the Menzies Carlton Hotel, Bournemouth

**This four star hotel in Bournemouth upgraded its heating system from atmospheric boilers to modern condensing boilers for its 76 bedroom hotel, timeshare apartments and leisure club.**

## Products

- Purewell VariHeat boilers
- Merley sequence controller

## Sector

- Hotel & Leisure
- Building
- Hotel
- Apartments
- Refurbishment

## Application

- Space heating 1260kW
- Modular boilers
- Domestic hot water



## The Old System: 16 x Purewell Classic Boilers (~80% Efficient)



Hamworthy Heating's Purewell VariHeat boilers were the natural choice to enable a seamless heating upgrade at the Menzies Bournemouth Carlton Hotel, a four star hotel on the east cliff of Bournemouth.

Cedar Green Commercial Heating and Building Solutions installed seven Purewell VariHeat 180kW condensing boilers in place of the existing sixteen Purewell Classic 70kW atmospheric boilers. The new boilers plus five remaining calorifiers provide the space heating and hot water for the entire seventy six bedroom hotel and adjoining timeshare apartments, including a leisure club with indoor pool and spa and outdoor swimming pool.

Danny Bulch, Director at Cedar Green commented, ***"We pride ourselves on giving customers continuity of their heating and hot water systems throughout refurbishment projects. It is vital for commercial premises such as hotels and hospitals to have no system downtime due to the services being critical to their business. With the number of boilers reducing from two rows to just one, we could keep a row of old boilers running whilst we installed the new equipment alongside."***

The Purewell VariHeat boilers are commonly used in refurbishment projects as they fit on the same footprint as old atmospheric boilers, and can easily be connected to existing pipework and make use of existing flue runs to speed up installation.

Midtherm, Hamworthy's flue partner, installed the new flue and lined the existing chimney to enable it to cope with a system that produces condensate.

# Hamworthy Solution

Project: Purewell VariHeat c upgrade at the Menzies Carlton Hotel, Bournemouth

## The New System: 7 x Purewell VariHeat c Boilers (~96% Efficient)



With older plant rooms access can inevitably be one of the main issues. The stairs to the Carlton Hotel's basement plant room are fairly steep and required the use of a crane to lift out the old boilers and install the new ones. Purewell VariHeat boilers can also be supplied for site assembly when access is problematic.

Danny went on to say, ***"It's always a pleasure to work with Hamworthy and their staff through the entire process from sales and technical assistance to despatch and commissioning. I only ever install Hamworthy boilers; they are easy to fit and reliable. The Carlton Hotel has seen their system upgraded from the early Hamworthy UR boilers through to the Purewell VariHeat boilers of***

***today. The upgrades have been straightforward due to the ease of replacement between old atmospheric and newer condensing models in Hamworthy's range. The newer models also provide benefits to the hotel of better efficiencies and lower service and maintenance costs, since the number of boilers have more than halved."***

For enhanced control of the multiple boiler system a Merley Sequence Controller was installed as well as an external air sensor to allow for weather compensation.

The Purewell VariHeat boiler's cast iron heat exchanger is complemented by an integral secondary condensing heat exchanger to provide exceptional seasonal efficiencies up to

108% net. The boiler range consists of 5 condensing models with outputs from 70kW to 180kW, and 4 non-condensing, high efficiency models, 65 kW to 125 kW.



*The existing chimney was lined to enable it to cope with condensate*

Your local contact is:

**British engineering excellence from Hamworthy Heating;  
the commercial heating and hot water specialists.**



Hamworthy Heating Limited  
Wessex House,  
New Fields Business Park,  
Stinsford Road,  
Poole, Dorset BH17 0NF

Tel: **01202 662500**  
Email: [sales@hamworthy-heating.com](mailto:sales@hamworthy-heating.com)  
[www.hamworthy-heating.com](http://www.hamworthy-heating.com)



**Hamworthy Heating Accreditations**  
ISO 9001 Quality Management System  
OSO 14001 Environmental Management System  
OHSAS 18001 Health & Safety Management System



The printed version of this brochure is produced using environmentally friendly print solutions in partnership with our suppliers.

Every effort has been taken to ensure the details in this guide are accurate. Hamworthy Heating does not, however, guarantee the accuracy or completeness of any information nor does it accept liability for any errors or omissions in the information.

Hamworthy Heating reserves the right to make changes and improvements which may necessitate alteration to product specification without prior notice.