

DECENTRALISED MECHANICAL EXTRACT VENTILATION (dMEV - System 3)

Decentralised Mechanical Extract Ventilation (dMEV) provides continuous background extract ventilation to a property.

The dMEV system works under the same principle as whole house mechanical extract ventilation (MEV) but with individual fans installed directly in the kitchen and every wet room in the property.

dMEV complies with current building regulations, is listed on the Product Characteristics Database and will help you achieve Code Level 3 in the Code for Sustainable Homes.

dMEV How does it work?



Decentralised MEV (dMEV) (whole home mechanical extract ventilation)

dMEV is a flexible solution offering three installation options; through the wall, wall/ceiling mounted with ducting to outside, as well as allowing the fan to be mounted inline and ducted to both the room and outside wall. dMEV is SAPQ listed for all three options.

A quiet, energy efficient 2 speed continuous ventilation system designed for wet room applications, the compact dMEV range of fans measure no more than a mini tablet device.



Technical

Typical dMEV installation with fan mounted through ceiling.

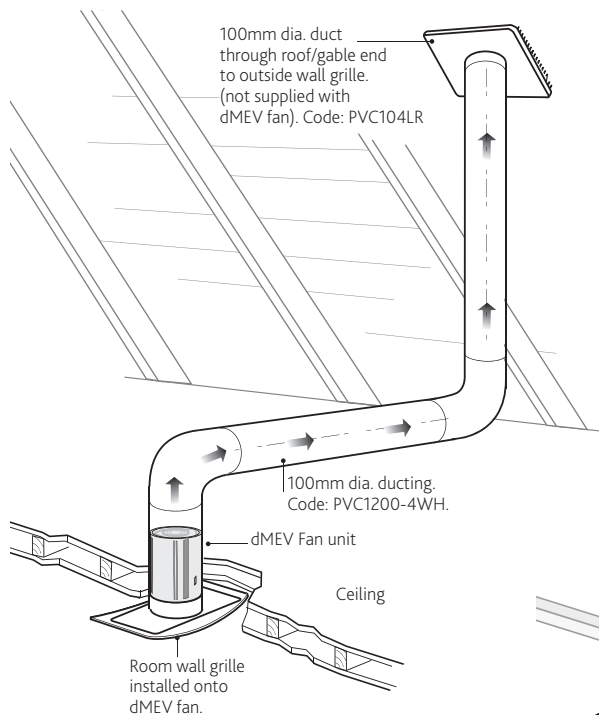

Typical dMEV installation with fan mounted through wall.

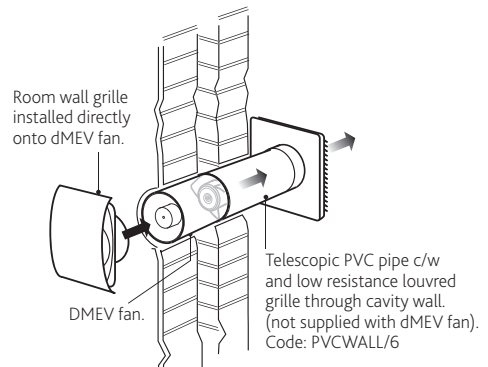

Typical dMEV induct/inline installation.

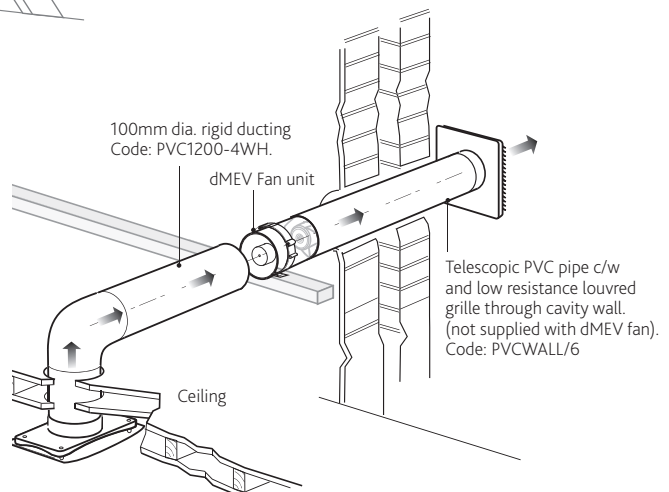

Performance

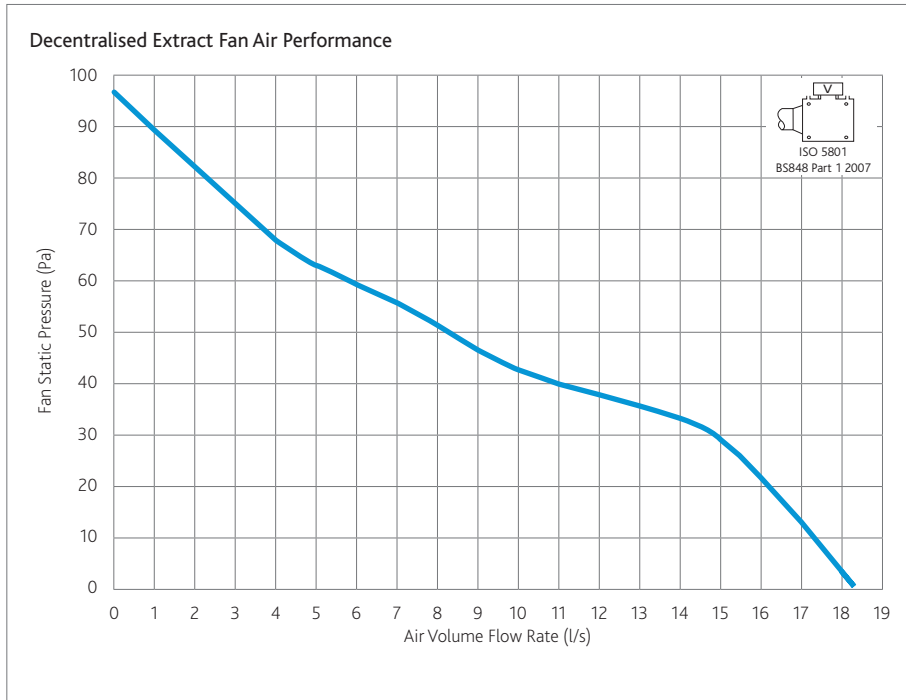

CODE DESCRIPTION

dMEV+ H

1 2 3

1. Decentralised Mechanical Extract Ventilation Unit
2. Decentralised Mechanical Extract Ventilation Unit with higher duty set points
3. Integral Humidistat (wall and ceiling mounted only)



Sap Appendix Q Test Results

	dMEV
Application	Specific Fan Power (W/l/s)
In-room fan - kitchen	0.20
In-room fan - other wet room	0.24
In-duct fan - kitchen	0.19
In-duct fan - other wet room	0.24
Through wall fan - kitchen	0.19
Through wall fan - other wet room	0.25

Performance, Electrical & Sound

	Extract setting (l/s)				Power consumption (Watts)				dBA @3m			
	Wet Room		Kitchen		Wet Room		Kitchen		Wet Room		Kitchen	
	Normal	Boost	Normal	Boost	Normal	Boost	Normal	Boost	Normal	Boost	Normal	Boost
dMEV	4	8	6	13	1	2.5	1.1	3	10	21	14	26
dMEV+	6	13	8	18	1.1	3	2.5	3.8	14	26	21	35
dMEVH	4	8	6	13	1	2.5	1.1	3	10	21	14	26
dMEV+H	6	13	8	18	1.1	3	2.5	3.8	14	26	21	35

General Arrangement

DIMENSIONS (MM) - FAN UNIT AND GRILLE

View of fan unit without grille

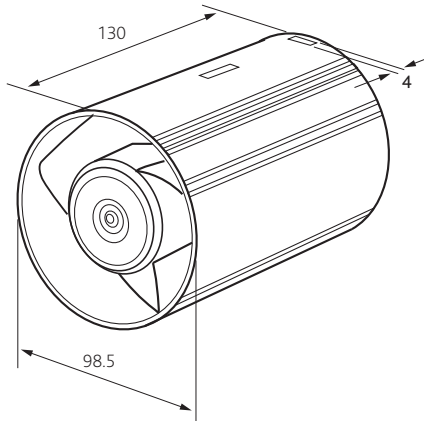

Unit weight: 0.5kg

Back view of fan unit and grille

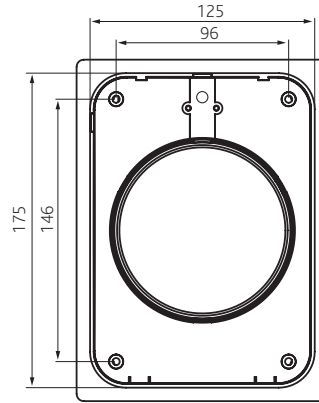

Side view of fan unit and grille

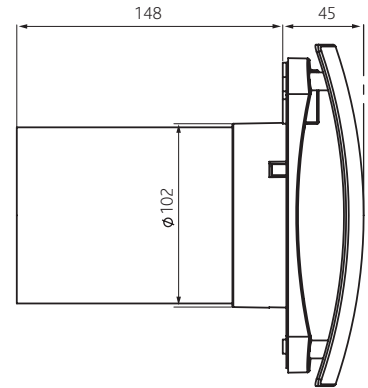

View of grille and fan unit

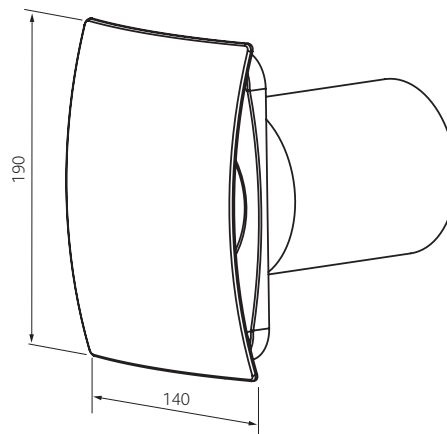

Top view of fan unit and grille

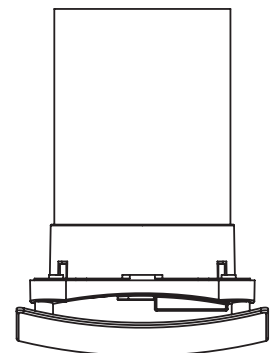

Ancillaries Available



Wall Kit

Code: (dMEV-WALLKIT)



Inline Installation Kit

Code: (dMEV-INLINE-KIT)



In-room Installation Kit

Code: (dMEV-INROOM-KIT)

Electrical Details

Voltage	230V	
Frequency	50Hz	
Operating Temperature	50°C	
Speed	Low (l/s)	Boost (l/s)
dMEV/H (Low)	4	8
dMEV/H (High)	6	13
dMEV+/H (Low)	6	13
dMEV+/H (High)	8	18

Wiring

UNIT SERVING BATHROOM OR KITCHEN (OPTIONAL BOOST)

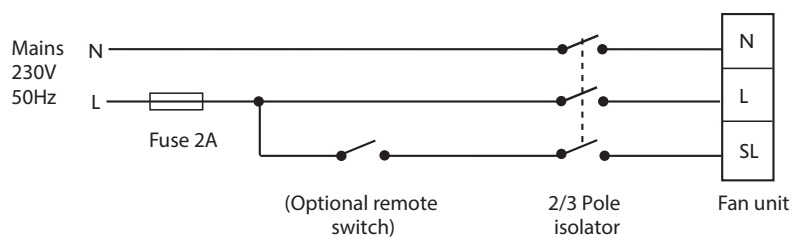

UNIT SERVING BATHROOM (VIA LIGHT SWITCH)

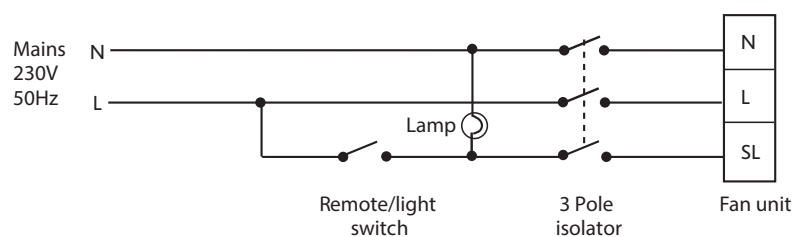

Consultants Specification

dMEV(H) / dMEV+(H) KITCHEN AND WET ROOM FAN

The unit shall be manufactured by Nuaire.

The National Calculation Method (SAP) identifier for this product is Decentralised Mechanical Ventilation Equipment (dMEV).

The unit shall be surface mountable or duct mounted using optional fixing kit. For duct mounting the fan section shall be removable and the fascia used as the inlet cowl.

The unit shall have 2 speed settings - low or high.

- The dMEV(H) unit set at low speed shall achieve 4 l/s and 8 l/s (Boost).
- The dMEV(H) unit set at high speed shall achieve 6 l/s and 13 l/s (Boost).
- The dMEV+(H) unit set at low speed shall achieve 6 l/s and 13 l/s (Boost).
- The dMEV+(H) unit set at high speed shall achieve 8 l/s and 18 l/s (Boost).

Unit noise level shall not exceed 21dBA @3m for kitchens and 14dBA for wet rooms (normal running).

The unit shall incorporate an injection moulded, 3 blade axial impeller.

The impeller shall be directly driven by a low energy, high efficiency EC motor, fitted with sealed, self-lubricating ball bearings.

IPX4 rated.

Suitable for bathroom zone 1 applications.

Motors shall have locked rotor protection to prevent overheating in the event of fan failure.

Each unit is capable of being set to comply with new edition (2010).

Part F – ventilation building regulations for (System 3) continuous mechanical extract (MEV) and new edition (2010) Part L - conservation of fuel and power.

The unit will meet the requirements of Part F for the following installations:

- Fan mounted within room with a maximum of 2.5m of rigid PVC ducting (Nuaire part number PVC1200-4WH),
2 off 90 Deg bends (Nuaire part number PVC490WH),
1 off low resistance extract grille (Nuaire part number PVC104LR).
- Fan mounted through a wall with 300mm rigid PVC ducting,
1 off low resistance extract grille. (Nuaire part number PVCWALL/6).
- Fan mounted in-duct with a maximum of 2.5m of rigid PVC ducting (Nuaire part number PVC1200-4WH),
2 off 90 Deg bends (Nuaire part number PVC490WH),
1 off low resistance extract grille (Nuaire part number PVC104LR).

Unit can comply with BRE digest 398 under continuous mechanical extract ventilation.

Meets the minimum fan power requirement of 0.5w/l/s in the 'Domestic Building Services Compliance Guide' (2010 edition).

The unit shall be designed for quietest operation to ensure occupant satisfaction.

The unit shall incorporate electrical connections to allow for the unit's "boost" airflow to be triggered by switched live.

The unit shall be supplied with a 5 year warranty. 1 Year parts and labour, additional 4 year parts.

dMEVH mounting options

Humidistat option available through wall and through ceiling mounted. Fully adjustable humidistat from 50-100RH.