

FLASH

ELECTRIC STEAM GENERATOR

Nominal pressure 4.5 bar



Main features

FLASH is an instantaneous steam generator. Its features make the FLASH generator an ideal steam producer for laundries and ironing machines, able to meet dry steam small and medium requests, preventing thermal plant overloads.

The generator is ready for a quick and easy installation, it's only needs are a connections to a power, hydraulic, steam lines and drain connection.

Electrical connections are made according to the safety norms, and converge to a single centralized panel.

The generator is provided with a level control, automatic water feed. Simple and effective utilization, thanks to the front control panel.

Electric and automatic steam generator, with variable power from 7 to 24 KW. The generator can be fed directly from the mains or from a special stainless steel reservoir.

The electric automatic steam generator is particularly suitable for polished surface ironing press operations (indicated for cotton material ironing) or equipped with a steam gun, and indicated for fur tapering and ironing. Available with a single group of resistors (three elements) or with two groups of independent resistors (six elements).

The boiler body is built according to PED rules in force, and equipped with INAIL safety devices.

Standard equipment:

- level indicator
- steam stop valve for flow start
- safety valve
- manometer
- pressure gauges
- automatic level regulator
- feed water pump
- non return valve
- drain valve

Optional accessories:

- condensate recovery stainless steel tank

Special versions:

- power delivery without neutral phase
- Nominal pressure 7 bar
- stainless steel AISI 304 version
- stainless steel AISI 304 water contact components

INDUSTRIAL RANGE
STEAM
FLASH

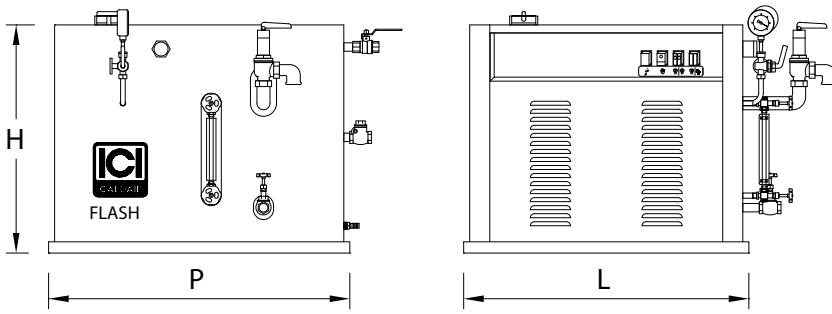

Characteristics	Code product	Effective capacity	Production steam*	Total volume	Total weight	Dimensions		
						H	L	P
Model		kW	kg/h	lt	kg	mm	mm	mm
FLASH 16	86930016	15	20,3	16	78	960	445	445
FLASH 24	86930024	20	27,1	24	78	765	550	488,5
FLASH 60	86930060A	60	81,4	55	113	568	710	750
FLASH 60 COMBI	86930120	60 x 2	81,4 x 2	55 x 2	230	1394	710	750
FLASH 180	86930180	60 x 3	81,4 x 3	55 x 3	315	1670	950	1160

* production with 80°C feed water