

## ES-OPUSDC EXTRACT FANS

ENERGY EFFICIENT, LOW NOISE, FLEXIBLE EXTRACT SOLUTION.



## BENEFITS

### QUIETEST SOLUTIONS

Advanced fan motor and impeller technology providing the quietest unit available.

### CONTINUOUS VENTILATION

Twin fans allow for automatic changeover to stand by fan in the event of fan failure. They also feature auto duty share.

### MOST EFFICIENT SYSTEMS

Latest DC motor design providing high performance with the lowest possible Specific Fan Power available in its class.

### SIMPLE COMMISSIONING

Integrated speed control enabling minimum and maximum fan speed to be easily adjusted giving an accurate, efficient site set up.

### QUICK & EASY INSTALLATION

Unique self locating mounting bracket enables the unit to be quickly and efficiently installed without additional fittings.

### INCREASED LIFECYCLE

Accurate speed control reduces wear and heat losses combined with the automatic change over in the twinfan version increase overall life of the units.

### HEALTHY ATMOSPHERE

Ecosmart sensors accurately control the ventilation levels ensuring that the rooms design requirement is met without wasting motor power or needlessly extracting conditioned air. Trickle function means that a background ventilation rate can be accurately set to keep rooms fresh when there is low occupancy.

### CONTROLLABILITY

A choice of 'on-board' and 'remote' control options are available and are completely interchangeable.

### ECOSMART SPEED CONTROL

All units have inbuilt energy efficient Ecosmart control included as standard to provide an easily commissioned packaged solution.

### REMOTE FAILURE INDICATOR

Visual and audible failure indicator  
Code: ES-AVI2.

### WARRANTY

The Ecosmart Opusdc has a 5 year warranty.

## TYPICAL INSTALLATION

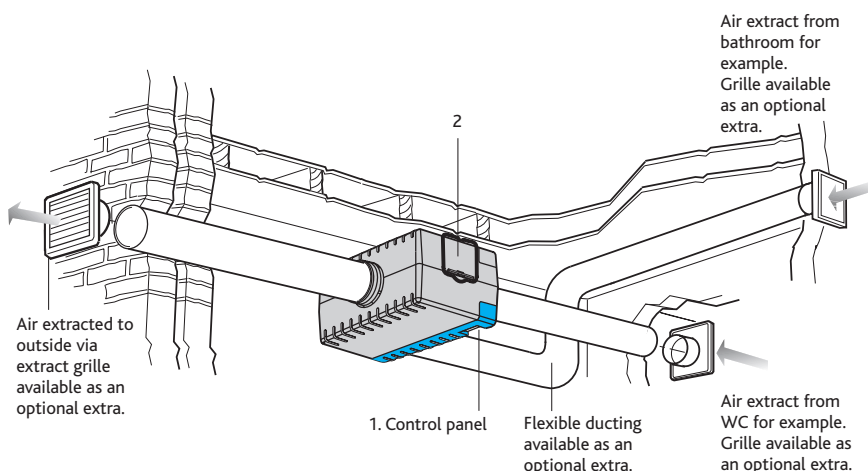

Easy control access.



Quick release bracket.



Plug-in connections.

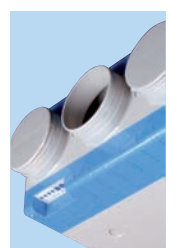

3 inlet connections.

PERFORMANCE - ES-OPUSDC EXTRACT FANS

Opus DC Single and Twinfan Units

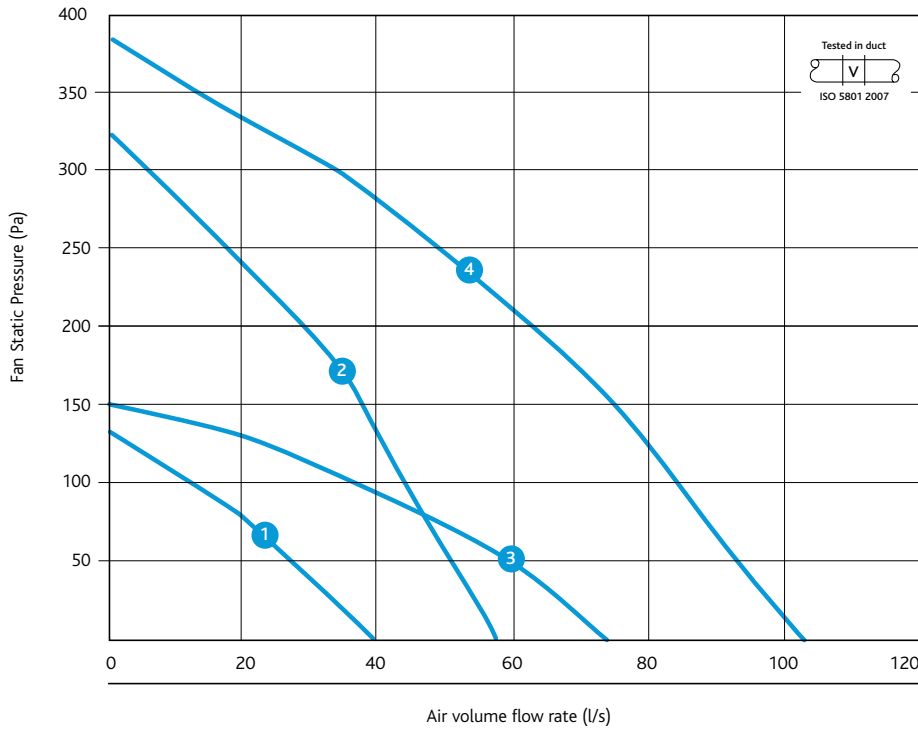

Casing

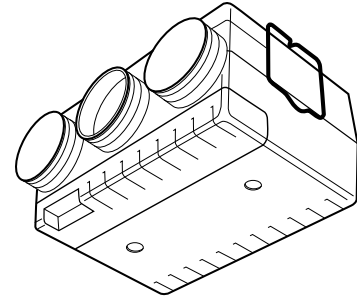

Code descriptions

ES - OPUSDC 40 - 2 M

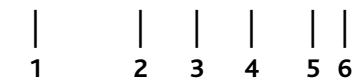

1. Ecosmart control
2. Opus range
3. DC=direct current, low watt
4. 40 = unit size
5. 2 = Twin model (See note\*)  
No reference = Single fan
6. M= Duct mounted

ES-OPUSDC EXTRACT FANS

ELECTRICAL & SOUND

Curve	Code	Input Power Watts	FLC amps	Induct Inlet/outlet noise	Sound Power Levels dB re:10-12w							Breakout dB(A)@3m
					Frequency Hz							
					125	250	500	1K	2K	4K	8K	
<b>Single Fan</b>												
1	ES-OPUSDC40-M	18	0.13	Induct inlet	65	52	45	41	36	24	25	29
				Induct outlet	64	56	53	52	49	42	34	
				Breakout sound levels	45	52	45	40	29	25	25	
2	ES-OPUSDC60-M	44	0.31	Induct inlet	72	58	53	50	45	33	30	34
				Induct outlet	75	67	62	61	60	55	49	
				Breakout sound levels	45	51	51	46	42	34	27	
<b>Twin Fan</b>												
1	ES-OPUSDC40-2M	18	0.13	Induct inlet	65	52	45	41	36	24	25	29
				Induct outlet	64	56	53	52	49	42	34	
				Breakout sound levels	45	52	45	40	29	25	25	
2	ES-OPUSDC60-2M	44	0.31	Induct inlet	72	58	53	50	45	33	30	34
				Induct outlet	75	67	62	61	60	55	49	
				Breakout sound levels	45	51	51	46	42	34	27	
<b>Dual Fan</b>												
3*	ES-OPUSDC75-M	33	0.23	Induct inlet	68	55	49	48	38	27	27	30
				Induct outlet	69	58	54	52	48	42	33	
				Breakout sound levels	52	48	49	44	31	28	25	
4*	ES-OPUSDC110-M	90	0.6	Induct inlet	76	68	61	54	49	40	37	37
				Induct outlet	76	71	63	63	62	58	52	
				Breakout sound levels	52	54	54	50	44	37	27	

\*Note: Unit sizes 75 and 110 have 2 fans running simultaneously as standard. In the event of failure the remaining fans performance will be reduced to approximately 2/3rds. Fully Ecosmart compatible with low voltage plug in control.

### INSTALLATION - ES-OPUSDC EXTRACT FANS

Integral mounting bracket screws into position on ceiling.

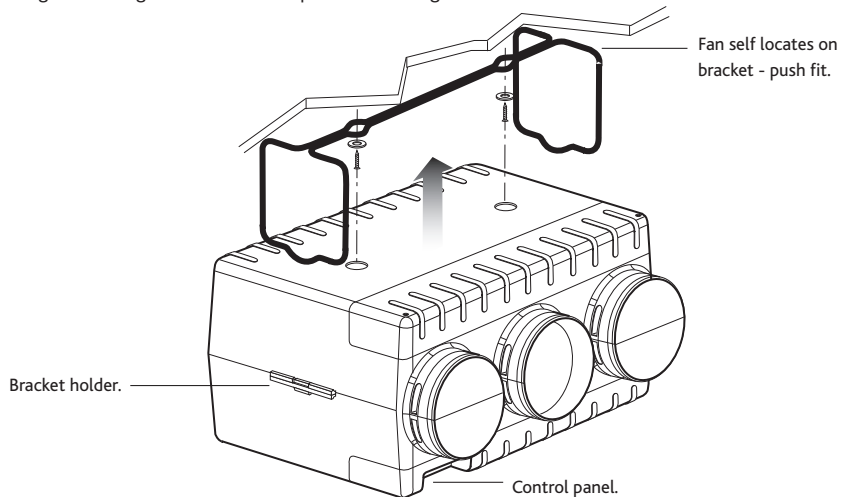

### DIMENSIONS (MM)

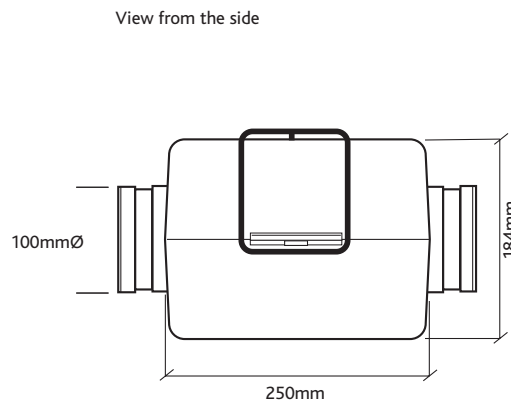
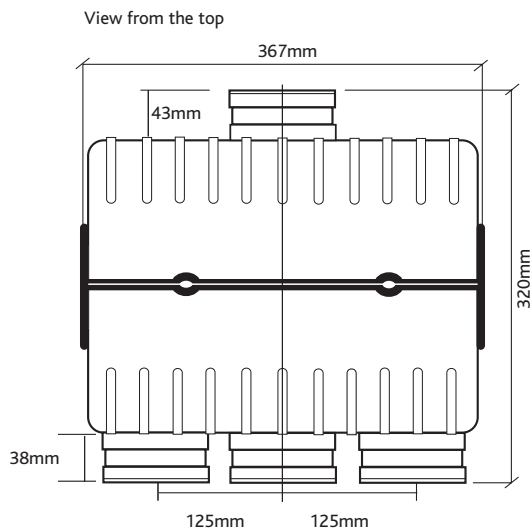

All spigots 100mm dia.  
Unit weight = 3kg

WIRING ES-OPUSDC

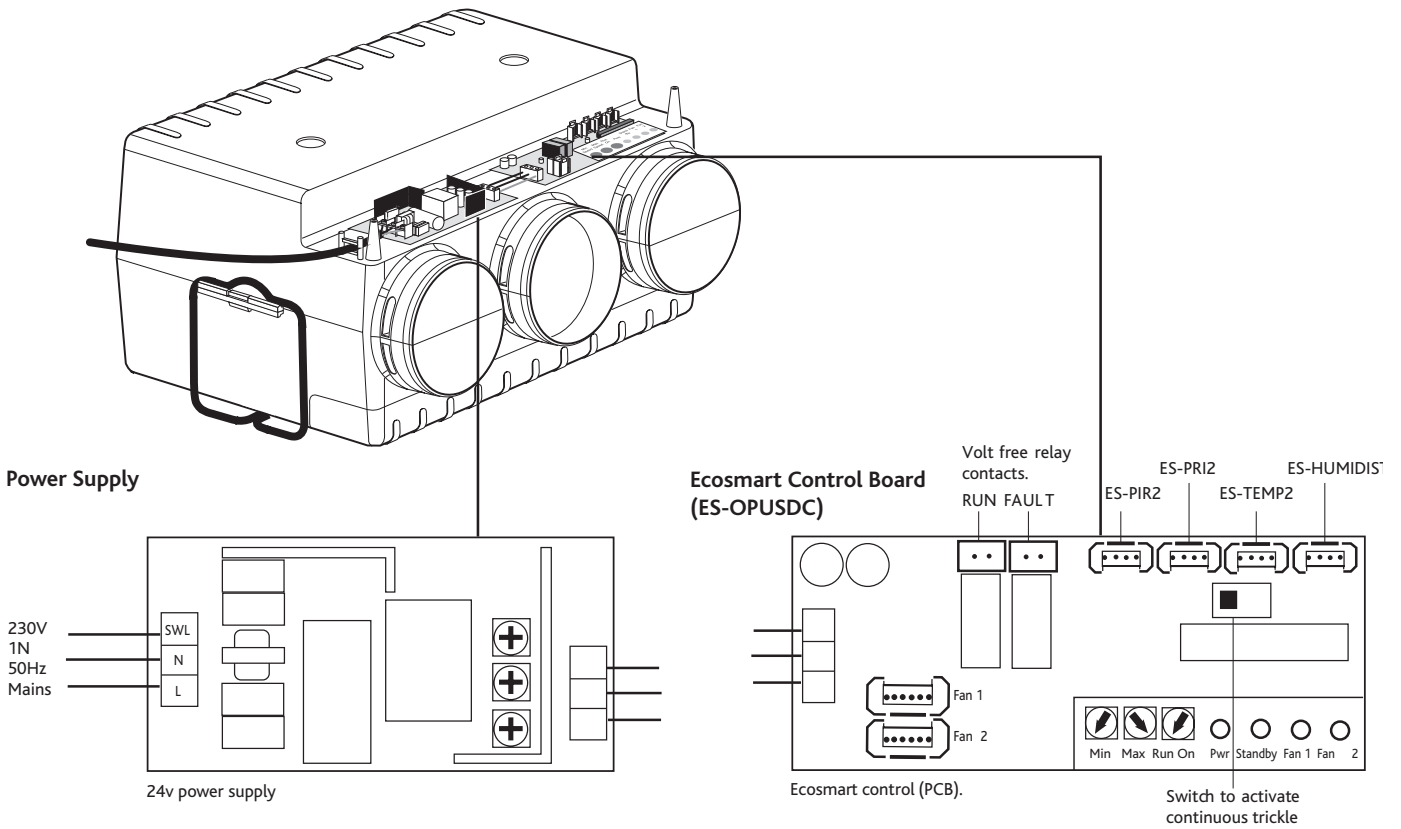

Unit ventilating one room

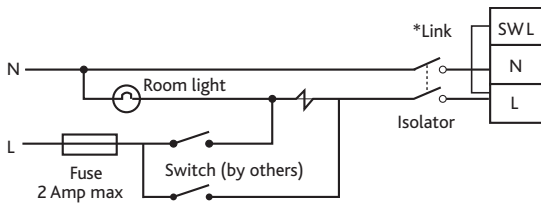

Unit ventilating two rooms

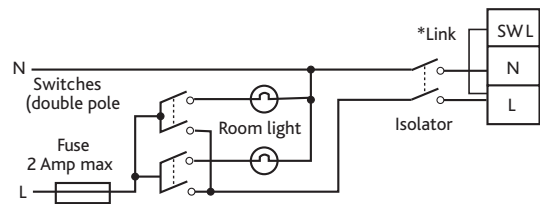

Unit ventilating one room (Using run on circuit)

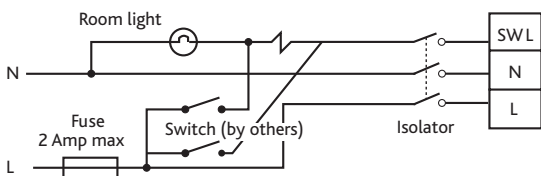

Unit ventilating two rooms (Using run on circuit)

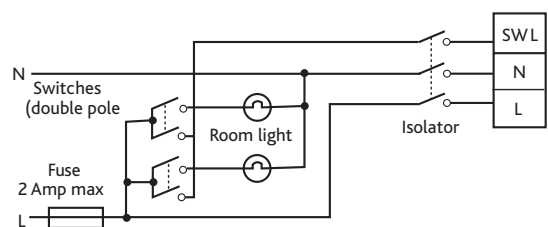

## CONSULTANTS SPECIFICATION

### OPERATION

The extract fans shall be as indicated on the drawings and shall be in accordance with the fan schedule in the specification. The vitiated air shall be extracted from each area via ductwork as shown. All necessary ductwork fittings and ancillaries shall be allowed for by the mechanical sub contractor. The extract fan shall automatically vary its speed as it receives signals from one of the interconnected sensors sited in the rooms being ventilated. When the signal is received the fan shall have the ability to increase speed gradually until the required level is achieved or it will work on a trickle and boost principle i.e. increase ventilation rate from the continuous background rate to the design maximum in one step.

### FAN SPECIFICATION

The fans shall have low energy, high efficiency DC fan/motor assembly with sealed for life bearings, mounted within an acoustically lined, 100% recyclable plastic case, ensuring a very efficient quiet solution. It shall have noise levels and power requirements as detailed in the specification and in accordance with the manufacturers details.

The unit shall incorporate a quick release mounting bracket. The bracket shall enable the unit to be mounted horizontally or vertically, enabling the unit to be removed without the aid of specialist tools. The depth of the unit shall not be greater than 190mm (including mounting bracket). The unit shall be constructed with one removable panel allowing quick and easy access to the electrical connections.

For commissioning purposes the unit shall have a miniature control panel mounted in its fascia facilitating high and low speed adjustment (trickle and boost) together with run on timer (1- 60minutes) and shall be accessible without the need of removing any access panels or the unit itself. Any adjustments shall be quickly and easily achieved with a standard screwdriver. The control panel shall also have status indication lamps on the underside of the unit.

Run and standby versions shall have autochangeover and duty share as standard, the fan shall changeover every twelve hours of run time to maximise the units effective life span.

Three number 100 diameter circular spigots on the system side of the unit are available to allow the ventilation of a number of rooms or points from a single unit. Two of the spigots have blanks fitted which are easily removed to facilitate the interconnection of ductwork.

### CONTROL SPECIFICATION

The fan unit shall have the following functions integrally mounted within the fan unit on a purpose made PCB, all such components pre-wired and factory fitted by the manufacturer: -

### ES-OPUSDC

- Integrated Infinitely variable speed control.
- Integral background ventilation commissioning facility.
- Integral boost ventilation commissioning facility.
- Autochangeover and duty share (twin fan unit only).
- Integral adjustable run on timer.
- Integral S/L terminal for boost trigger from remote switch, e.g. light switch.
- 4no. IDC sockets for interconnection of Ecosmart fans or low voltage sensors using pre-plugged 4-core low voltage cable. Multiple fans can be interconnected and run from one or more sensor or controller.
- Remote volt free run and fail status indication.
- Facia mounted fan failure, system status indication as follows:
  - Fan 1 status.
  - Fan 2 status.
  - Power to fan.
  - System standby.
  - 5 year warranty.

Fan shall be the ES-Opusdc type unit as manufactured by Nuaire.

The user control and low voltage sensors are supplied complete with a 10m length of low voltage, pre-plugged cable to facilitate their interconnection (other length of cables available).

The manufacturer's recommendations should be observed at all times.