

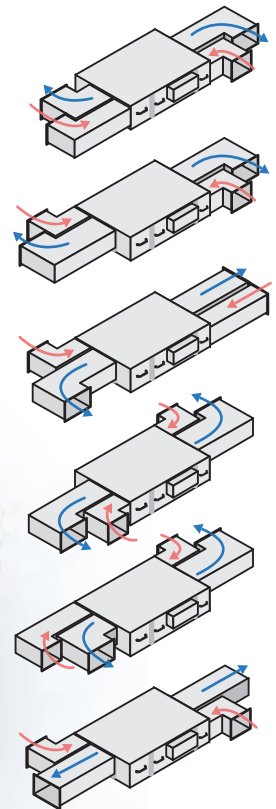

NOW AVAILABLE WITH NEW BEND SILENCERS



# XBOXER XBC

HEAT RECOVERY SOLUTIONS  
ENERGY EFFICIENT PRODUCT RANGE

WITH NEW **ecosmart** CONTROL PLATFORM



FOR THE COMPLETE VENTILATION SOLUTION

















# XBOXER XBC HEAT RECOVERY SOLUTIONS, OFFER THE MOST EFFICIENT, COMPACT DESIGN & QUIETEST SOLUTION AT THE LOWEST INSTALLED COST

▼XBC85-V-LCO  
Vertical fan unit shown. Ecosmart Connect control panel fitted internally.

HIGH EFFICIENCY UP TO 92%

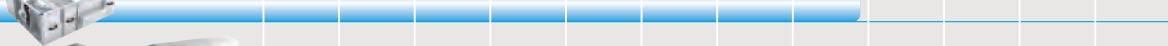

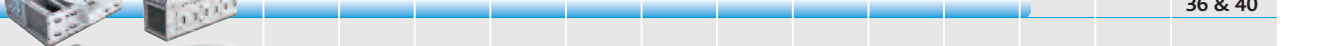
## WHICH UNIT DO YOU REQUIRE?

Model	m <sup>3</sup> /s	0	0.1	0.2	0.3	0.4	0.5	0.6	0.7	0.8	0.9	1	2	3	Page No.
XBC10															16
XBC15															18
XBC25															20
XBC45															22
XBC55															24
XBC65															26
XBC75															36 & 40
XBC85															38 & 42

- UK's No. 1 - Energy efficient range of packaged heat recovery units
- **LOWEST NOISE** - Patented construction
- **HIGHEST EFFICIENCY** - Exceeding Part L and Section 6 requirements aiding energy modelling and BREEAM
- **COMPACT AND FLEXIBLE** - Allows for quick and simple onsite installation
- **EXTENSIVE CONTROL SOLUTION** - Ecosmart Control Platform can provide optimum building efficiency (BMS/BEMS)
- **PACKAGED SOLUTION** - Lowest installed cost available on the market
- **UK DESIGNED, DEVELOPED AND MANUFACTURED** - Stocked and available in 10 days\*
- **5 YEAR WARRANTY\*** - Peace of mind

\*Contact Nuaire for details.

▼ XBC75-H-LAT Horizontal fan unit shown.  
Unit has **Adapt Trend** control.



▼ XBC45-H-LES Horizontal fan unit  
with **Ecosmart Classic** control.

**HIGH  
EFFICIENCY  
UP TO  
96%**

## XBC MARKET LEADING HEAT RECOVERY - CONTENTS

<b>XBC10-85 RANGE</b>	<b>3</b>	<b>XBC10-65 TECHNICAL DATA</b>	<b>16</b>	<b>CONSTANT PRESSURE</b>	<b>50</b>
1. XBC10-65 features & benefits	4	1. XBC10	16	1. How Constant Pressure works	50
2. XBC75-85 features & benefits	6	2. XBC15	18	2. Constant Pressure Dampers	51
<b>ECOSMART CONTROL PLATFORM</b>	<b>7</b>	3. XBC25	20	3. Constant Pressure Performance and Technical Information	52
1. History & Pedigree	7	4. XBC45	22	<b>OUR CUSTOMERS</b>	<b>54</b>
2. Overview of Ecosmart Control Platform	8	5. XBC55	24	1. Project Specific Solutions	54
3. Basic Control (BC)	9	6. XBC65	26	2. Alternative Heat Recovery Solutions	56
4. Ecosmart Classic Control (ES)	9	7. XBC10-65 Ancillaries	28		
5. Ecosmart Connect Control (CO)	9	8. XBC10-65 <b>NEW</b> Bend Silencers	30		
6. Ecosmart Adapt Control (AT)	9	9. XBC10-65 Consultant Specifications	32		
7. Features of Ecosmart Platform	10	10. XBC10-65 Unit Wiring	34		
8. Ecosmart Sensors & Enablers	12	<b>XBC75-85 TECHNICAL DATA</b>	<b>36</b>		
<b>SELECTION &amp; REGULATIONS</b>	<b>14</b>	1. XBC75 Horizontal	36		
1. BIM support & library	14	2. XBC85 Horizontal	38		
2. Building regulations	15	3. XBC75 Vertical	40		
		4. XBC85 Vertical	42		
		5. XBC75-85 Ancillaries	44		
		6. XBC75-85 Consultant Specifications	46		
		7. XBC75-85 Unit Wiring	48		

# XBOXER XBC10-65 ENERGY EFFICIENT HEAT RECOVERY UNITS WITH SPECIALIST ACOUSTIC TREATMENT PROVIDING LOW NOISE LEVELS

**CIBSE BUILDING PERFORMANCE AWARDS 2014**  
Winner

UP TO  
**96%**  
EFFICIENCY

XBC65-H-LCO ▶



◀ XBC45-H-LES

## LOWER NOISE & ENERGY CONSUMPTION

■ **GUARANTEED LOW SOUND LEVELS** - Units have Asymmetric, high mass, double skinned wall construction (patented) with integral acoustic barrier mat (XBC10 units contain specialist acoustic treatment) ensuring low breakout noise levels.

■ **LATEST EC TECHNOLOGY** - Performance optimised backward curved impellers and IP54 EC motors provide low specific fan powers and stepless speed control without tonal noise generation.

■ **MEETS CURRENT LEGISLATION AND BUILDING REGULATIONS** - Lower energy consumption and better SBEM score.

■ **CONTINUOUS ACOUSTIC HOUSING** - Matched silencers reduce breakout and provide a superior acoustic solution.

■ **CLASS L2 LEAKAGE** - Units are tested to meet Class L2 leakage requirements.

## ACHIEVES BUILDING REGULATIONS

■ **HIGH EFFICIENCY HEAT EXCHANGER** - Counterflow heat exchanger (Eurovent certified) with efficiencies of up to 96% with segmented 100% bypass (patent applied for) automatic control and actuator.

■ **BUILT IN ECOSMART CLASSIC, CONNECT OR ADAPT (TREND) CONTROL OPTIONS**

Ecosmart Energy efficient demand control ventilation solution. Ecosmart Connect control option delivers extensive flexibility and capability and uses Ethernet technology to integrate into supervisory control networks using BACnet. See page 8 for further details. Ecosmart Adapt allows for project specific controls i.e. Trend or Siemens. Contact Nuair for details.

■ **SPACE SAVING SOLUTION** - Low casing height from 260mm for ceiling/under floor/slab mounted applications. Most compact case by duty size.

■ **AIR QUALITY** - Optional duct or surface mounted sensors to monitor CO<sub>2</sub> levels as required in BB101. Refer to pages 12 - 13.

## UNIQUE INTELLIGENT DESIGN PRACTICE

■ **100% INTEGRATED SUMMER BYPASS** - The bypass operates automatically via integrated temperature sensors and pre-defined control algorithm/ programme.

■ **QUICK COMMISSIONING** - Integrated supply and extract fan allows precise system duty which can be quickly and accurately set. (Ecosmart models only).

■ **UNIQUE LAYOUT DESIGN** - Provides flexibility in unit ductwork connections – Supply/Discharge connections are on unit centreline. Intake/Extract connections are configurable on site to either side of the unit.

■ **FLEXIBLE ACOUSTIC COMPACT SUPPLY & EXTRACT SECTION** - Double skinned acoustically lined compact section with supply and discharge channel ready for ducting to be attached. Ideal for space restricted ceiling voids.

BASIC CONTROL OPTIONS

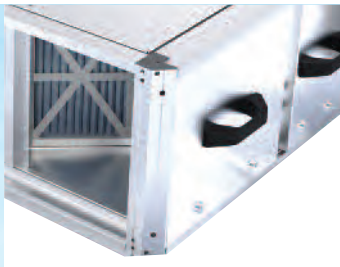

▲ Lowest depth (from 260mm) units available, ideal for space restricted ceilings.

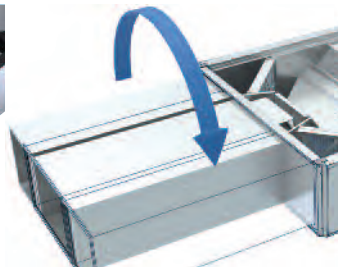

▲ Matched silencers are separate and can be fitted to suit left/right side. (1050/1250/1600mm lengths).

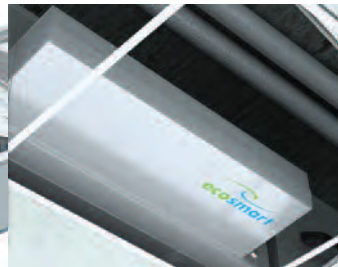

▲ All Ecosmart Control Platforms have a 90° pivoting control box for easy commissioning.



▲ Double skinned wall construction (patented) integral acoustic barrier mat.

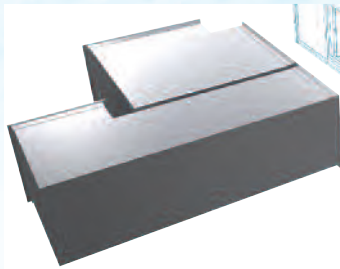

▲ Bend silencers are available for projects where straight matched silencers cannot be fitted.



▲ Optional exhaust and intake terminals for all models. Code examples: XBC15-EXHAUST-RT & XBC15-INTAKE-RT.



▲ Only 260mm clearance required for filter access (Ecosmart models). 2 spare filters included (G4).



▲ Mounting brackets incorporated into the unit. Units fit flush to slab.

FLEXIBLE SOLUTION

■ **HEATING COIL OPTIONS** - Units are fitted with LPHW heater battery, 4-port valve and actuator or Electric heater battery and burst fired temperature controller. No heater option is also available. (For DX & cooling modules contact Nuairé).

■ **BASIC CONTROL OPTION AVAILABLE** - Allowing for a control system to be designed, specified, fitted & tested by others.

■ **WEATHER PROTECTION** - Weather roof can be selected as an ancillary on all models and fitted on site.

■ **MANUFACTURED IN UK** - All units are manufactured in the UK. Contact Nuairé for details of availability.

■ **ENERGY EFFICIENT DEMAND CONTROL** - Ecosmart control compatibility provides a simple 'plug & go' control solution for stand-alone control with trickle & boost operation as standard. A variety of BMS interface options are available.

SAVES TIME & MONEY ON SITE

■ **MANUFACTURED FROM CORROSION RESISTANT ALUZINC** - Aluzinc can last 5 times longer than galvanised steel providing higher wear resistance.

■ **HIGH CAPACITY FILTERS** - Units are fitted with four high capacity pleated G4 filters (spare filters are included in unit). F7 filters are available. (Note: XBC10 has G3 filters).

■ **NEW ECOSMART CONNECT CONTROL SYSTEM** - Stand-Alone control and full BMS via BACnet (MS/TP). The system controller is augmented by application specific unit interface and diagnostic circuits. Controller software is pre-configured and the unit/control assembly is functionally tested at works (Refer to Ecosmart Control brochure for technical details).

■ **EASY MAINTENANCE** - Side access as standard will provide full access to components and for quick filter removal and replacement. Bottom access is available for filter only. Example code is XBC15-H-LES-BA. (Only on sizes 10-45).

MAKES LIFE EASIER

■ **EASY FIT DOUBLE SKINNED MATCHED SILENCERS WITH QUICK FIT BRACKET** - Can be easily incorporated into existing drop rod supporting systems. 3 lengths of matching silencers are available, 1050, 1250 and 1600mm. Fixing kit included. **All XBC matched silencers are double skinned.**

■ **ADVANCED CONDENSATE REMOVAL** - Miniature condensate pump fitted as standard and incorporates an alarm function. **If alarm is triggered unit will automatically be placed in bypass mode preventing further condensate production. Unit operation will otherwise be unaffected.**

■ **WIDE RANGE OF ANCILLARIES & FILTERS** - Includes matched silencers, weather roof, F7 filters, roof terminals and NEW bend silencers.

■ **5 YEAR WARRANTY** - On Ecosmart Classic, Ecosmart Connect and Adapt models for peace of mind. Basic control models have a 2 year warranty.

# XBOXER XBC75-85 ENERGY EFFICIENT HEAT RECOVERY UNITS

## WITH DUTY UP TO 1.5m<sup>3</sup>/s

**NEW**  
HIGH EFFICIENCY  
COUNTERFLOW  
HEAT EXCHANGER  
UP TO 92%



XBC85-V-LCO ▶  
Vertical unit fitted with  
Ecosmart Connect control.



▲ XBC75-H-LAT  
Horizontal unit fitted with  
Ecosmart Adapt Trend control.

### LOWER NOISE & ENERGY CONSUMPTION      ACHIEVES BUILDING REGULATIONS      UNIQUE INTELLIGENT DESIGN PRACTICE

- **VERY LOW SOUND LEVEL SOLUTION -**  
Units have a rigid pentapost framework with 25mm infill panels containing inert high density acoustic infill ensuring low breakout noise levels.
- **LATEST EC TECHNOLOGY -** Performance optimised backward curved impellers and IP54 EC motors provide low specific fan powers and stepless speed control without tonal noise generation.
- **MEETS CURRENT LEGISLATION AND BUILDING REGULATIONS -** Lower energy consumption and better SBEM score.
- **CONTINUOUS ACOUSTIC HOUSING -** Matched silencer modules help reduce breakout and provide a superior acoustic solution.
- **CLASS L2 LEAKAGE -** Units are tested to meet Class L2 leakage requirements.

- **HIGH EFFICIENCY HEAT EXCHANGER -** Counterflow heat exchanger (Eurovent certified) with efficiencies of up to 92% with segmented 100% bypass (patent applied for) automatic control and actuator.
- **BUILT IN ECOSMART CLASSIC, CONNECT OR ADAPT (TREND) CONTROL OPTIONS**  
Ecosmart Energy efficient demand control ventilation solution. Ecosmart Connect control option delivers extensive flexibility and capability and uses Ethernet technology to integrate into supervisory control networks using BACnet. See page 8 for further details. Ecosmart Adapt allows for project specific controls i.e. Trend or Siemens. Contact Nuair for details.
- **CONSTANT PRESSURE OPTION\* -** Improves the energy performance of a building using a centralised ventilation system, and guarantees lower energy costs for the end user. (Applies to ES CO & AT models only). Refer to page 50 for further details on Constant Pressure.

- **SPACE SAVING SOLUTION -** Ideal for plant room/roof top applications. Most compact case by duty size.
- **AIR QUALITY -** Optional duct (ES-CO<sub>2</sub>) or surface (ES-CO<sub>2</sub>RM) mounted sensors to monitor CO<sub>2</sub> levels as required in BB101.
- **100% INTEGRATED SUMMER BYPASS -** The bypass operates automatically via integrated temperature sensors and a pre-defined control algorithm/programme.
- **ECOSMART PRE-PROGRAMMED SOFT START FUNCTION -** Helps prevent electrical overloading and minimises mechanical wear.
- **QUICK COMMISSIONING -** Integrated supply and extract fan allows precise system duty which can be quickly and accurately set. (Ecosmart Classic, Connect & Adapt models only).

BASIC CONTROL OPTIONS



▲ Integral base frame (76mm high) with slots for forklift arms ensure easy manoeuvrability on site.



▲ Fans slide out for ease of maintenance.



▲ Wide range of frost coils and dampers. LPHW heater battery supplied with 2 port PICV valve and actuator.

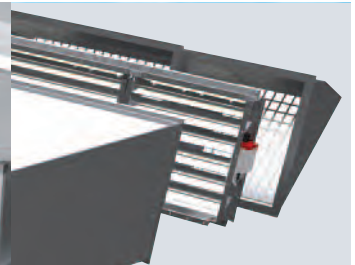

▲ Range of weather kits, exhaust / intake and roof terminals available.

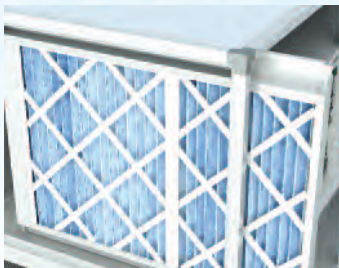

▲ G4 filters as standard other options available, contact Nuair.



▲ Weather roof's are factory fitted only. Code example XBC85-V-LESWP.



▲ Double deck silencer modules 900mm length incorporate base frame.



▲ Quick access to fans, heat exchangers, condensate and control panel.

FLEXIBLE SOLUTION

■ **HEATING COIL OPTIONS** - Units are fitted with LPHW heater battery, 2-port valve and actuator or Electric heater battery (contact Nuair for details). No heater option is also available as standard. (For DX, cooling and chilled water modules contact Nuair).

■ **BASIC CONTROL OPTION AVAILABLE** - Allowing for a control system to be designed, specified, fitted and tested by others.

■ **WEATHER PROTECTION** - Weather roof is factory fitted only. Code example XBC85-V-LESWP.

■ **MANUFACTURED IN UK** - Contact Nuair to ensure your required project deadlines are met.

■ **ENERGY EFFICIENT DEMAND CONTROL** - Ecosmart control compatibility provides a simple 'plug & go' control solution for stand-alone control, with trickle and boost operation as standard. A variety of BMS interface options are available.

SAVES TIME & MONEY ON SITE

■ **NEW ECOSMART CONNECT CONTROL SYSTEM** - Allows Stand-Alone control and full BMS integration via BACnet (MS/TP). The system is augmented by application specific unit interface and diagnostic circuits. Controller software is pre-configured and the unit/control assembly is functionally tested at works (Refer to Ecosmart Control brochure for technical details).

■ **HIGH CAPACITY FILTERS** - Units are fitted with two high capacity G4 panel filters. F7 filter modules are available.

■ **MANUFACTURED FROM CORROSION RESISTANT ALUZINC** - Aluzinc can last 5 times longer than galvanised steel providing higher wear resistance.

■ **EASY MAINTENANCE** - Side access as standard providing full access to internal components.

■ **MATCHING SILENCERS** - Quick and easy to fit on site.

MAKES LIFE EASIER

■ **ADVANCED CONDENSATE REMOVAL** - Miniature condensate pump fitted as standard and incorporates an alarm function. If alarm is triggered unit will automatically be placed in bypass mode preventing further condensate production. Unit operation will otherwise be unaffected.

■ **WIDE RANGE OF ANCILLARIES & FILTERS** - Includes matched silencers, F7 filters and roof terminals.

■ **5 YEAR WARRANTY** - On Ecosmart Classic and Ecosmart Connect models for peace of mind. Basic control models have a 2 year warranty.

# ECOSMART CONTROL PLATFORM - IT'S SO SMART IT'S SIMPLE

## DEMAND VENTILATION SOLUTIONS – DESIGNED FOR EFFICIENCY AND PERFORMANCE

Nuair have a pedigree for designing and manufacturing energy efficient ventilation equipment and matched control systems. Our very first control was produced in the late 1980's.

Nuair was the first ventilation manufacturer to introduce low voltage energy saving control systems. Its fans with 'Ecosmart' technology varied the ventilation rate to suit occupant levels. Ecosmart was launched in 2002 and was revolutionary within the industry by providing the first "plug and play" control system.

Nuair continues to lead in the industry with the expansion of their Ecosmart Controls Platform.



Energy efficient demand based control fitted with Trend IQ422 controller. Allows for unitary control and full BMS integration via BACnet IP (by others).  
Controller software is basic and ready for 'project specific' program to be loaded.  
**Ecosmart Adapt with Trend has a 5 year warranty.**  
For other options of Ecosmart Adapt contact Nuair.



NEW Energy efficient demand based control providing a network connectivity and advanced functionality. Full BMS integration via BACnet (MS/TP). (Upgrade to IP network available). **Ecosmart Connect has a 5 year warranty.**



UK's leading Energy Efficient 'plug and play' solution for over 20 years. Provided with BMS interface, trickle and boost as standard.  
**Ecosmart Classic has a 5 year warranty.**

**THE MOST SUCCESSFUL ENERGY CONTROL EVER -  
DEMAND VENTILATION AT YOUR FINGER TIPS**

## BASIC CONTROL

Supplied with terminal box for supply and extract fan motor wiring and for interfacing to custom built control panels (by others). **Basic control has a 2 year warranty.**



# ECOSMART CONTROL PLATFORM - IT'S SO SMART IT'S SIMPLE

## ECOSMART ADAPT

TREND IQ422/12/LAN/BAC/230 INSIDE WITH FULL BMS INTEGRATION VIA BACNET.

*"The management and control of modern buildings grow ever more sophisticated. A Building Energy Management system (BEMS) must be tailored to suit each customer's specific control requirements. It must provide efficient HVAC control, coupled with the flexibility to accommodate changes in occupancy status and staff relocation at short notice; whilst simultaneously delivering improved comfort conditions. A BEMS must also provide real time management information and control, enabling customers to achieve significant energy savings". (TREND)*

Ecosmart Adapt with Trend provides control of the ventilation including the heating, or cooling allowing unitary control and full BMS integration via BACnet IP. The Ecosmart Adapt with Trend control system includes an IQ422/12/LAN/BAC/230 controller which is pre-configured and the unit and control assembly is functionally tested at Nuair before customer delivery.

### REDUCED INSTALLATION & ON-SITE COMMISSIONING TIME ON NEW & RETROFIT PROJECTS -

Advanced tools within the control automate many tasks, simple to use displays minimise data input, whilst reducing commission time and potential human error.

- **Ease of use** - Using Ecosmart Adapt with Trend will deliver substantial savings on utility costs.
- **Peace of mind** - Ecosmart Adapt with Trend has a 5 year warranty. **(Example Code: XBC75-H-LAT)**

## ECOSMART CONNECT

Ecosmart Connect provides control of the ventilation including the heating, or cooling allowing unitary control and full BMS integration via BACnet (MS/TP). (Upgrade to IP network available).

The Ecosmart Connect controller is pre-configured and the unit and control assembly is functionally tested at Nuair before customer delivery.

### REDUCED INSTALLATION & ON-SITE COMMISSIONING TIME ON NEW & RETROFIT PROJECTS -

Advanced tools within the control automate many tasks, simple to use displays minimise data input, whilst reducing commission time and potential human error.

- **Ease of use** - Using Ecosmart Connect will deliver substantial savings on utility costs.
- **Peace of mind** - Ecosmart Connect has a 5 year warranty. **(Example Code: XBC75-H-LCO)**

## ECOSMART CLASSIC

Varying the ventilation rate in a building to suit changing occupant levels used to be an expensive option – Ecosmart brings this within everyone's pocket.

Minimising energy losses through re-heating (or cooling) the air replaced through ventilation is at the top of the agenda; building regulations make this a necessity. Ecosmart not only saves energy and carbon emissions it prolongs the life of the heat recovery unit.

Choosing Ecosmart is your reliable option, used by design engineers for many years and is now an integral feature of most Nuair fans.

- **Saves time on site** - Ecosmart controls are all pre-assembled, configured and installed directly into the heat recovery units, this includes valves and actuators, pipework etc. which helps significantly reduce the time spent on site.
- **Simpler system** - No need for VCD (directly on the fan) no wasted energy or noise generation because air volume can be precisely set via integrated speed control.

**(Example Code: XBC75-H-LES)**

- **Simple & precise commissioning** - As recommended in Part L, Ecosmart enables the system to be accurately commissioned via integrated speed control. If the unit is controlled by 0-10V BMS the system's response to a 0-10V dc BMS signal is given in the table below.

	Ventilation mode	Cooling mode*	Heating mode*
Local control	0.00	-	-
OFF / trickle	0.25	-	-
Speed 1	0.50	0.75	1.00
Speed 2	1.50	1.75	2.00
Speed 3	2.50	2.75	3.00
Speed 4	3.50	3.75	4.00
Speed 5	4.50	4.75	5.00
Speed 6	5.50	5.75	6.00
Speed 7	6.50	6.75	7.00
Speed 8	7.50	7.75	8.00
Speed 9	8.50	8.75	9.00
Speed 10	9.50	9.75	10.00

\* Only available on relevant unit.

## BASIC CONTROL

Basic control is fan speed only and are suitable for 2-10V adjustment (by others). The heat recovery unit will have a side mounted terminal box for connection to the fans (230V, 50Hz LNE and 2-10V\*) and bypass actuator (where applicable). Basic control is for BMS by others.

Basic control has a 2 year warranty. \*For XBC 75 and XBC 85 (400V 3ph, 50Hz LNC and 2 - 10V).

**(Example Code: XBC75-H-LBC)**

# ECOSMART CONTROL PLATFORM - IT'S SO SMART IT'S SIMPLE

	BASIC CONTROL (BC)	ecosmart classic (ES)	ecosmart CONNECT (CO) BACnet (MS/TP)	ecosmart adapt (AT) Based on TREND IQ44 BACnet (IP)
<b>CONTROLLER SOFTWARE</b>				
Controller Software		N/A	Advanced Software	Basic Software (Can be re-written by others)
Heat Exchange Bypass Control Strategy		Basic	Optimised	Basic
Supply Temperature Control Strategy		Yes	Yes	Yes
Room Temperature Control Strategy		No	Yes	No
Switched Live Enable Input		Yes	Yes	Yes
Switched Live Fan Boost		No	No	Yes
Switched Live Configurable Input (Heat or Fan Boost)		No	Yes	No
Volt Free Enable Input		No	Yes	Yes
Volt Free Fan Boost		No	No	Yes
Volt Free Configurable Input (Heat or Fan Boost)		No	Yes	No
Trickle Mode		Yes	Yes	Yes
Fan Run-On		Yes	Yes	Yes
Fan Run-On (Intelligent)		No	Yes	No
Run/Fault/Heat/Cool Volt Free Outputs		Yes	Yes	Yes
I/O Damper control		Yes	Yes (via run relay)	Yes (via run relay)
Heat Dissipation Run-on		Yes	Yes	Yes
Frost Protection Routine		Yes	Yes	Yes
Low Supply Temp Fan Cut-out		No	Yes	Yes
Scheduling		Yes via ES-LCD	Yes	Yes
CO2 Based Fan PID Loop		ES-CO2	Yes	Yes
Humidity Based Fan PID Loop		ES-HUMIDISTAT2	Yes	No
Pressure Based Fan PID Loop		CP version available	Yes	No
Night Cooling Mode		No	Yes	Yes
Purge Mode		No	Yes	Yes
Hibernate Mode (Open all valves)		No	Yes	No
Fan Speed Adjustment		Yes	Yes	Yes
Fan Speed Control only	Yes	No	No	No
0 - 10V Fan speed Input		Yes	Yes	Yes
0 - 10V Temperature Sensor Input		No	Yes	No
0 - 10V Humidity Sensor Input		No	Yes	No
0 - 10V Pressure Sensor Input		No	Yes	No
0 - 10V CO2 Sensor Input		No	Yes	No
<b>CONTROLLER HARDWARE</b>				
Fail safe thermal trip		Yes	Yes	Yes
Condensate Pump Monitoring		Yes	Yes	Yes
Din Rail Mounted Control		No	Yes	Yes
Quick Connect Terminals		No	Yes	Yes
24VAC Auxiliary		No	Yes	Yes

# ECOSMART CONTROL PLATFORM - IT'S SO SMART IT'S SIMPLE

	BASIC CONTROL (BC)	ecosmart classic (ES)	ecosmart CONNECT (CO) BACnet (MS/TP)	ecosmart adapt (AT) Based on TREND IQ44 BACnet (IP)
<b>HMI</b>				
Commissioning Display		Yes only Via commissioning PCB	Yes	By Others
BACnet LCD Touch Screen Display		No	Yes	By Others
<b>ROOM MODULES</b>				
Plug & Play Sensors		Yes	Yes	No
Max Number of Sensors		32 devices on any system	4 sensor modules*	By Others
Quick connect plugs		Yes	Yes	By Others
Twisted pair cable compatible		No	Yes	By Others
Commissioning Port		No	Yes	By Others
Temperature		Yes	Yes	By Others
CO2		Yes	Yes	By Others
Humidity		Yes	Yes	By Others
3-Speed Override		No	Yes	By Others
PIR		Yes	Yes	By Others
Setpoint Adjust		Yes (on sensor)	Yes	By Others
Multiple Setpoints Supported		No	Yes	By Others
Room Temperature Display		No	Yes	By Others
Room Humidity Display		No	Yes	By Others
Fan Speed Display		No	Yes	By Others
Occupancy Status Display		No	Yes	By Others
Network Error Display		Yes	Yes	By Others
<b>NETWORKING</b>				
BEMS compatible		No	Yes	Yes
BMS compatible		0-10V Input	BACnet via MS/TP (BACnet via IP optional)	(BACnet via IP)
<b>MONITORING</b>				
Web connectivity		NA	Yes	Yes
Energy Monitoring		NA	Yes	Participation via Trend network
Energy Metering		NA	Yes	Participation via Trend network

\*Each sensor module can have multiple sensors.

For further details of Ecosmart Controls Platform, refer to website: [www.nuaire.co.uk](http://www.nuaire.co.uk)

# ECOSMART CONTROL PLATFORM - IT'S SO SMART IT'S SIMPLE

## ecosmart classic SENSORS & ENABLERS

All Ecosmart Classic Systems must include at least one enabler.  
(N.B. when used, BMS control and time clocks take over all other enablers).

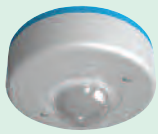

### ES-PIR2 (Enabler)

Detects movement and activates system. Incorporates a system status LED, overrun timer and timer adjustment.

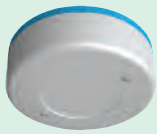

### ES-TEMP2 TEMPERATURE (Sensor)

Modulate fan speed based on room temperature. Incorporates two system status LEDs. (Green = OK, Red = Failure) and temperature set point level adjustment.



### ES-THERMOSTAT2 (Enabler)

Activates the system when the temperature is above set point. Incorporates two system status LEDs. (Green = OK, Red = Failure) and temperature set point level adjustment.



### ES-RH2 RELATIVE HUMIDITY (Sensor)

Modulate fan speed based on RH level. Incorporates two system status LEDs. (Green = OK, Red = Failure) and RH set point level adjustment.

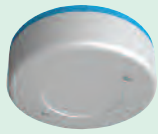

### ES-AVI2 (Enabler)

When fan failure occurs the AVI will flash a warning. Supplied with pre-plugged 10m length of communication cable.

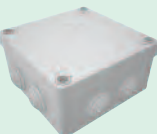

### ES-CI SEMI-AUTOMATIC USER CONTROL

Fan, heating & cooling selected by external volt free switch, speed selected by 0-10V signal.



### ES-HUMIDISTAT2 (Enabler)

Activates the system when the RH level is above set point. Incorporates two system status LEDs. (Green = OK, Red = Failure) and RH set point level adjustment.



### ES-JB JUNCTION BOX

Designed to be compatible with Ecosmart System this unit is supplied with a pre-plugged 10 metre length of communications cable and has 8 further ports.

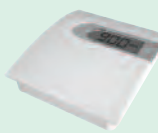

### ES-CO2RM (Sensor) ES-CO2RMPP (Sensor)

Surface mounted room carbon dioxide (CO<sub>2</sub>) sensors incorporate a temperature sensor. RM = SELV option, RMPP complete with SELV AC powers supply.

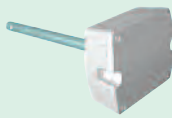

### ES-CO2 (Sensor)

Duct mounted sensor to modulate fan speed based on CO<sub>2</sub> levels. Connect to fan directly. Pre-wired with 2m cable (not adjustable).

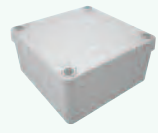

### ES-HTCSIG (Enabler)

Signal conditioning circuit for humidity, temperature and CO<sub>2</sub> sensors.



### SWITCHED LIVE (by others)

Any mains voltage signal connected to the switched live terminal (S/L) in the unit. This affects the connected fan only.

## ecosmart ROOM MODULES CONNECT



### ESCO-TPL

Ecosmart Connect Room Module - Temperature and PIR.



### ESCO-THS

Ecosmart Connect Room Module - Temperature and Humidity.



### ESCO-TDPL

Ecosmart Connect Room Module - Temperature, Display and PIR.



### ESCO-TDHL

Ecosmart Connect Room Module - Temperature, Display and Humidity. (Displays either temperature or humidity).



### ESCO-TDHS

Ecosmart Connect Room Module - Temperature, Display and Humidity. (Humidity is not displayed).

## TOUCH SCREENS & MANUAL USER CONTROLS



**ES-LCD (Enabler)** Touch screen user control in white incorporating time clock facility. This can control the function of the fan by manual setting or using a set of timed programs.



**ES-UCF** Manual 'on' and 'off' system user/speed control. Incorporates two system status LEDs (Green = OK, Red = Failure).



### ESCO-LCD

Touch screen display. The ESC-LCD is a user friendly operator interface featuring BACnet® communication and a colourful, graphic display with touch-screen interface. It is powered by 12-24VAC / VDC.

# ECOSMART CONTROL PLATFORM - IT'S SO SMART IT'S SIMPLE



**ESCO-TDS**  
Ecosmart Connect Room Module - Temperature and Display.



**ESCO-TS**  
Ecosmart Connect Room Module - Temperature.



**ESCO-CL**  
Ecosmart Connect Room Module - CO2.



**ESCO-TDFS**  
Ecosmart Connect Room Module - Temperature, Display and Fan Speed Override.



**ESCO-THPL**  
Ecosmart Connect Room Module - Temperature, Humidity and PIR.



**ESCO-IPN**  
The BACnet IP to MS/TP Router exchanges information between networks and allows the controller to communicate on an IP network. One router is required for each MS/TP network.

## THERMISTOR TEMPERATURE SENSORS



Code: TB/T1/S – For duct or immersion use. Short 150mm.  
TB/T1/L – For duct use only. Long 400mm

Low cost thermistor sensors comprising insertion, clamp-on, and outside air versions. The insertion sensor may be used for duct or immersion purposes. It has a 6 mm diameter brass probe which is suitable for retrofit immersion applications and will fit most existing pockets (universal fitting kit option).

### FEATURES

- Low cost
- High quality thermistors
- Brass probes
- M20 conduit entry with M16 cable gland
- IP67 housing
- Quarter turn quick release lid
- Easy to wire
- Universal kit option for retrofit of immersion sensors
- Adjustable insertion depth flange option for duct sensors

## DUCT HUMIDITY & TEMPERATURE SENSORS



Code: HT/D – Duct and thermistor sensor (+/-3%).

Duct mounted relative humidity and temperature sensors for HVAC applications. The certified 2% high accuracy (±2%) and standard 3% versions offer excellent linearity and stability over a wide humidity range (10 to 90 %RH).

### FEATURES

- Pre-calibrated for ease of commissioning
- IP65
- Operates over 10 to 100 %RH non-condensing
- ± 3% accuracy versions
- 2 part connectors for ease of installation
- Humidity sensor element protected by replaceable filter
- Capacitive humidity sensing element provides excellent long term stability
- Adjustable depth duct mounting flange option

## CO2 SENSORS



Code: CO2/T/D – Duct sensor.  
Code: CO2/T/S – Space carbon dioxide concentration and temperature sensor.

The CO2 duct and space sensors monitor the carbon dioxide concentration and temperature of the air. The space sensors have additional options of humidity monitoring and a 4 digit display. The display will show the measured values in succession. The duct sensor has a quick-release lid to facilitate installation.

### FEATURES

- Low cost, high quality thermistor temperature sensor
- Humidity monitoring option for space sensor
- Optional digital display for space sensor
- IP67 housing (duct sensor)
- Quarter turn quick release lid (duct sensor)
- Two part terminals to facilitate wiring
- 24 Vac/dc supply
- Adjustable depth duct mounting flange option



**IQVIEW4** Touch screen display, (6 x 4 inch). FPK/Plate – Mounting plate.  
IQVIEW4/SM BOX – Surface mount box for wall or panel.  
Transformer for IQVIEW4 included.  
ACC/24V - 230/24 VAC, 36 VA



**IQVIEW8** Touch screen display. (10 x 6 inch). IQVIEW8/SM BOX – Surface mount box for flat surfaces.  
Transformer for IQVIEW8 included.  
ACC/24V – 230/24 VAC, 36 VA



**SDU** Display. RD/SDU-IQ2COMMSCABLE/3m – RJ11 plug to RJ11 plug cable (3m) for SDU.

## PRODUCT SELECTION

**NUAIRE'S CUSTOMERS ARE INVOLVED IN THE DEVELOPMENT OF EVERY TYPE OF EDUCATIONAL ENVIRONMENT WITH VARYING COMPLEXITY** INCLUDING THE DEVELOPMENT OF NEW BUILD AND REFURBISHMENT PROJECTS IN LIVE ENVIRONMENTS

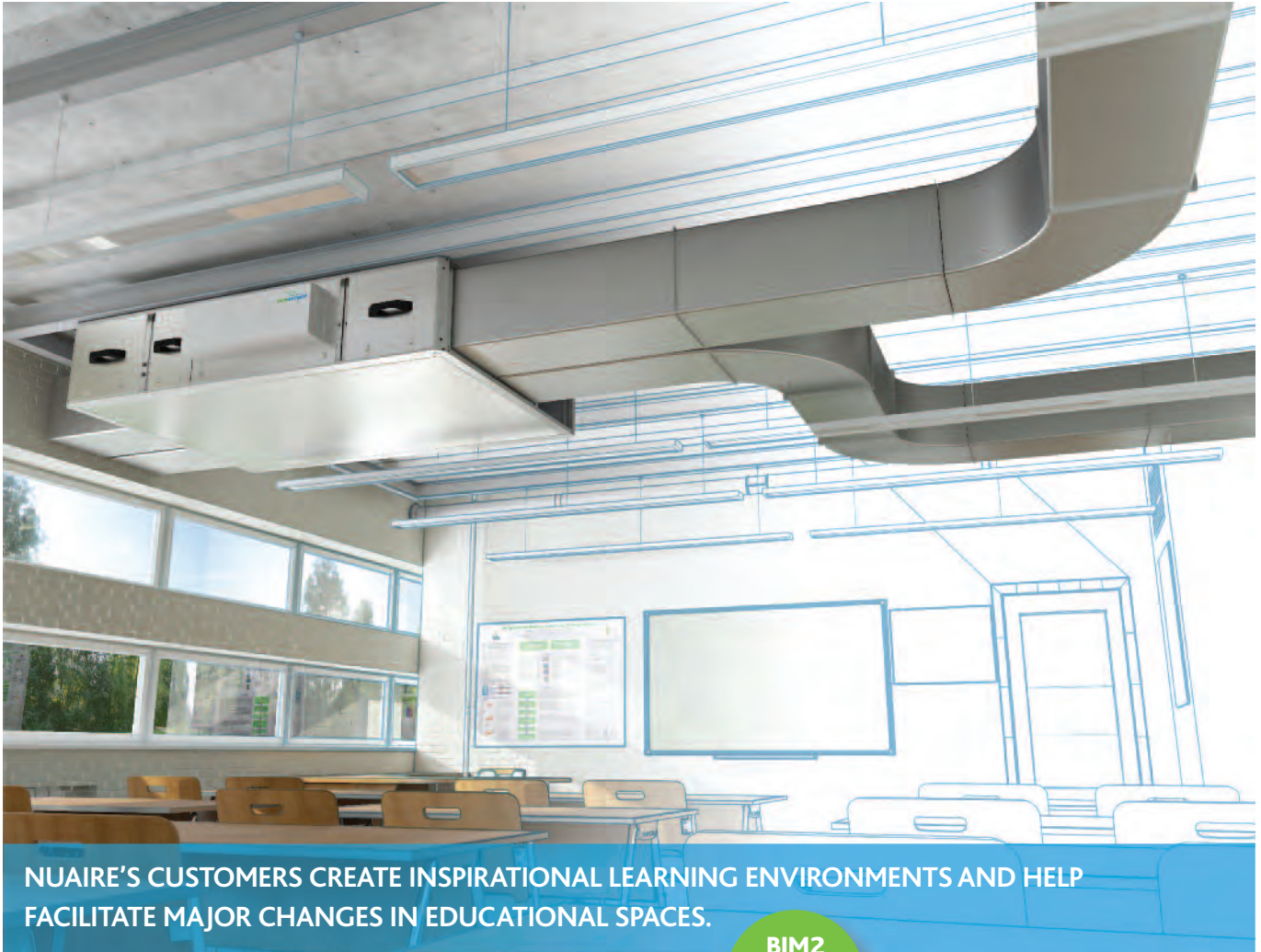

Nuaire assists its customers to deliver their projects and to keep within their project programme, quality and cost.

Over the years Nuaire's knowledge and understanding of current government education legislation has grown significantly.

The Priority School Building Programme (PSBP) Facilities Output Specification launched by the Education Funding Agency (EFA) has proposed some significant, positive and welcome changes to school ventilation specifications. To find out more visit: [www.gov.uk/government/collections/priority-school-building-programme-psbp](http://www.gov.uk/government/collections/priority-school-building-programme-psbp).

**We understand the many challenges and regulations that modern building ventilation must meet... and our technical team are on hand to assist with product selections.**

Building Information Modelling (BIM) is both a new technology and a new way of working. BIM is a term that has been around for a while in manufacturing and engineering industries, and is now beginning to make an impact in the construction sector.

**BIM2  
COMING  
SOON**



Nuaire has a dedicated BIM Team offering libraries of Revit® compatible BIM models to meet customers' exact specification.

Nuaire's libraries offer collision detection through geometry, connection positions and weights.

Project specific performance criteria and support for design, project management and building operations can be requested which will result in improved design efficiency.

To download Nuaire's Revit® compatible BIM models simply visit [www.nuaire.co.uk/BIM](http://www.nuaire.co.uk/BIM) and click on the library. Alternatively, simply email the team [BIM@nuaire.co.uk](mailto:BIM@nuaire.co.uk) with your request.



Scan here for BIM Library.

# COMPLYING WITH BUILDING REGULATIONS

The following information is relevant to the selection of fans for Ventilation Systems, indicating the maximum specific fan powers allowed under Part L (Refer to the Non-domestic Building Services Compliance Guide: 2013 Edition for further details).



The SFP for the entire system (including both supply & extract fans) shall be less than that allowed by these figures. The following tables are the maximum values allowed under Building Regulations when finally commissioned.

Air distribution system	Specific fan power (W/(l/s))	
	New Buildings	Existing Buildings
Central balanced mechanical ventilation system with heating and cooling	1.6	2.2
Central balanced mechanical ventilation system with heating only	1.5	1.8
All other central balanced mechanical ventilation systems	1.1	1.6
Zonal supply system where the fan is remote from the zone, such as ceiling void or roof mounted units	1.1	1.4
Zonal extract system where fan is remote from zone	0.5	0.5
Zonal supply and extract ventilation system such as ceiling void or roof units serving a single room or zone with heating and heat recovery	1.9	1.9
Local balanced supply and extract ventilation system / such as wall roof units serving a single area with heating and heat recovery	1.6	1.6
Local supply or extract ventilation units such as window / wall / roof units serving a single area (e.g. toilet extract)	0.3	0.4
Other local ventilation supply or extract units	0.5	0.5
Fan assisted terminal (VAV) unit	1.1	1.1
Fan coil units (rating weighted average*)	0.5	0.5
Kitchen extract, fan remote from zone with grease filter	1.0	1.0

\*Note: The weighted average is calculated by the following formula:

$$\frac{P_{\text{mains},1} \cdot \text{SFP}_1 + P_{\text{mains},2} \cdot \text{SFP}_2 + P_{\text{mains},3} \cdot \text{SFP}_3 + \dots}{P_{\text{mains},1} + P_{\text{mains},2} + P_{\text{mains},3} + \dots}$$

where  $P_{\text{mains}}$  is useful power supplied from the mains in W

### Extending SFP for additional components in new and existing buildings

Component	(SFP (W/(l/s)))
Additional return filter for heat recovery	+0.1
HEPA filter	+1.0
Heat recovery - thermal wheel system	+0.3
Heat recovery - other systems	+0.3
Humidifier / dehumidifier (air conditioning system)	+0.1

**Example:** For a central mechanical ventilation system with heating and cooling, and heat recovery via a plate heat exchanger plus return filter:

$$\text{SFP} = 1.6 + 0.3 + 0.1 \text{ W/(l/s)} = 2.0 \text{ W/(l/s)}$$

### Recommended minimum dry heat recovery efficiency for heat exchangers in new and existing buildings

Heat exchanger type	Dry Heat recovery efficiency
Plate heat exchanger	50%
Heat pipes	60%
Thermal wheel	65%
Run around coil	45%

## SECTION 6 (2015 EDITION)

Permissible maximum specific fan power and pressure drop in air distribution systems.



Maximum specific fan powers in air distribution systems new and existing buildings.

System type	Specific fan power (W/(l/s))	
	New Buildings	Existing Buildings
Central balanced mechanical ventilation system with heating and cooling	1.6	2.2
Central balanced mechanical ventilation system with heating only	1.5	1.8
All other central balanced mechanical ventilation systems	1.1	1.6
Zonal supply system where fan is remote from the zone, such as ceiling void or roof mounted units	1.1	1.4
Zonal extract system where fan is remote from zone	0.5	0.5
Zonal supply and extract ventilation units, such as ceiling void or roof units serving single room or zone with heating and heat recovery	1.9	1.9
Local balanced supply and extract ventilation system such as wall/ roof units serving single area with heat recovery	1.6	1.6
Local supply or extract ventilation units such as window/ wall/ roof units serving single area (e.g. toilet extract)	0.3	0.4
Other local ventilation supply or extract units	0.5	0.5
Fan assisted terminal VAV unit	1.1	1.1
Fan coil unit (rating weighted average*)	0.5	0.5
Kitchen extract, fan remote from zone with grease filter	1.0	1.0

\*The weighted average is calculated by the following formula:

$$\frac{P_{\text{mains},1} \times \text{SFP}_1 + P_{\text{mains},2} \times \text{SFP}_2 + P_{\text{mains},3} \times \text{SFP}_3 + \dots}{P_{\text{mains},1} + P_{\text{mains},2} + P_{\text{mains},3} + \dots}$$

where  $P_{\text{mains}}$  is useful power supplied from the mains in W

### Extending SFP for additional components in new and existing buildings

Component	SFP (W/(l/s))
Additional return filter for heat recovery	+0.1
HEPA filter	+1.0
Heat recovery – thermal wheel system	+0.3
Heat recovery – other systems	+0.3
Humidifier/ dehumidifier (air conditioning system)	+0.1

### Recommended minimum dry heat recovery efficiency for heat exchangers in new and existing buildings

Heat exchanger type	Dry heat recovery efficiency
Plate heat exchanger	50%
Heat pipes	60%
Thermal wheel	65%
Run around coil	45%

# XBC10 HORIZONTAL HEAT EXCHANGE UNITS

## PERFORMANCE & TECHNICAL INFORMATION

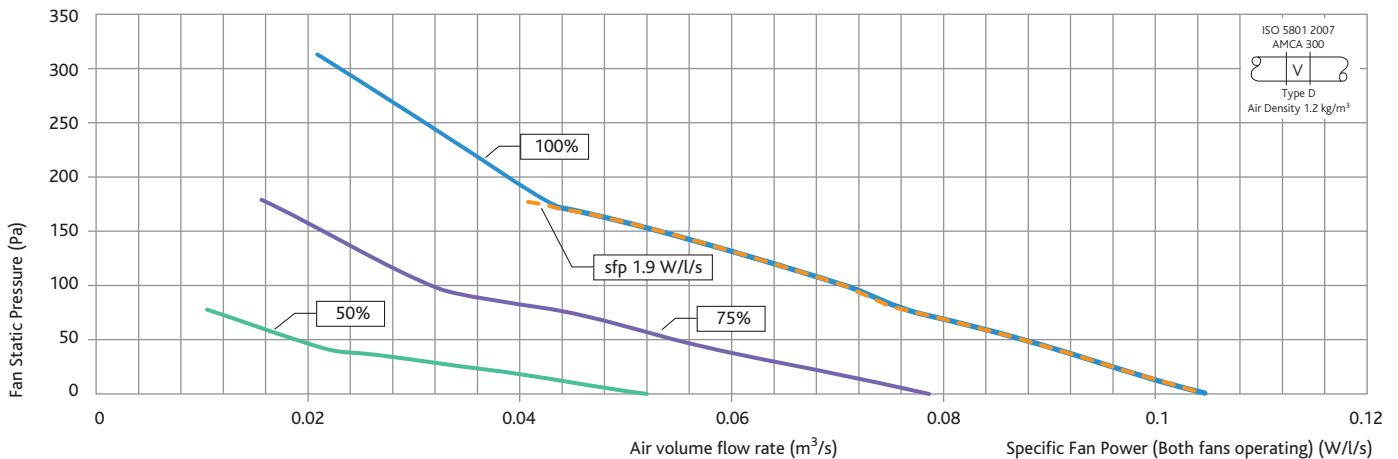

### XBC10 UNIT PERFORMANCE

Fan Speed	External Static Pressure (Pa)	Fan Speed					Fan Speed	External Static Pressure (Pa)	Fan Speed		
		0	50	100	200	300			0	50	100
100%	Airflow (m³/s)	0.105	0.088	0.070	0.039	0.023	50%	Airflow (m³/s)	0.052	0.020	0.003
	sfp (W/l/s)	0.786	0.938	1.179	2.115	3.587		sfp (W/l/s)	0.288	0.750	5.000
	dB(A)@3m	24						dB(A)@3m	< 20		
75%	Airflow (m³/s)	0.078	0.055	0.032	0.010						
	sfp (W/l/s)	0.449	0.636	1.094	3.500						
	dB(A)@3m	<20									

Specific Fan Power figures are the total for both fans operating.

For accurate figures, please refer to Nuair Fan Selection Programme at [www.nuair.co.uk](http://www.nuair.co.uk)

Unit Code	Voltage / Phase / Frequency	Input Power (W)	FLC / SC (A)	Max Operating Temperature	Fan Speed (rpm)	Unit Weight (kg)	Packed Weight (kg)	Pallet / crate dimensions (mm)
XBC10-H-L**	230 / 1 / 50	160	1.5 / 1.5	40°C	3200	147	197	1850L x 1400W x 505H
XBC10-H-E**	230 / 1 / 50	160	9 / 9	40°C	3200	155	205	1850L x 1400W x 505H
XBC10-H-N**	230 / 1 / 50	160	1.5 / 1.5	40°C	3200	143	193	1850L x 1400W x 505H

\*\*Add relevant code ie: BC, ES, CO or AT for control type. \*Includes 1.5kW Electric Heater.

### FAN UNIT DIMENSIONS (mm)

Note: All models (BC, ES, CO or AT) have a fold down (90°) pivoting control box for easy commissioning.

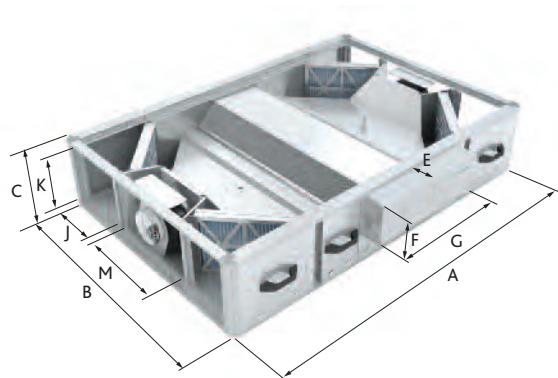

### XBC10 FAN CONFIGURATION

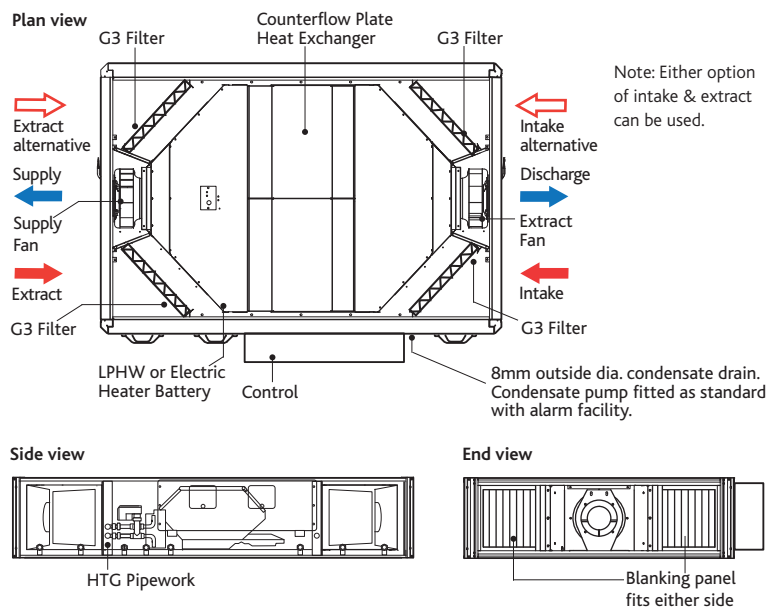

Fan Unit Dimensions (mm)			Control for all Models Dimensions (mm)			Rectangular Aperture Dimensions (mm)			Weather Roof for all Models Code XBC10-H-WP			Service & Maintenance Requirements	
A	B	C	E	F	G	J	K	M	H	x	W		x
1600	1000	260	120	200	670	242	218	351	65	1000	1600		

The unit is designed for side access as standard and must be installed with a minimum of 260mm clearance from a wall or barrier. This will provide access to filters, coil, fan, heat exchanger, condensate tray and pump.

2 attenuator flanges are attached to every unit. Add 50mm to dimension 'A' to include both flanges. Weather roof is separate code and can be retro fitted on site.



# XBC10 HORIZONTAL HEAT EXCHANGE UNITS

## PERFORMANCE & TECHNICAL INFORMATION

### XBC10 FAN - SOUND DATA

Fan Speed	Sound Power Levels (dB re 1 pW)	Frequency (Hz)								Spherical dBA@3m	Fan Speed	External Static Pressure (Pa)								Spherical dBA@3m
		63	125	250	500	1000	2000	4000	8000			63	125	250	500	1000	2000	4000	8000	
100%	Induct Intake	68	57	50	51	57	50	42	38	24	50%	53	42	35	36	42	35	27	23	<20
	Induct Supply	73	69	60	61	63	59	54	52			58	54	45	46	48	44	39	37	
	Induct Discharge	73	70	60	62	63	60	55	53			58	55	45	47	48	45	40	38	
	Induct Extract	67	56	50	50	56	50	40	36			52	41	35	35	41	35	25	21	
	Casing Radiated	59	55	40	41	39	35	32	21			44	40	25	26	24	20	<20	<20	
75%	Induct Intake	62	51	44	45	51	44	36	32	20										
	Induct Supply	67	63	54	55	57	53	48	46											
	Induct Discharge	67	64	54	56	57	54	49	47											
	Induct Extract	61	50	44	44	50	44	34	30											
	Casing Radiated	53	49	34	35	33	29	26	<20											

\*Casing Radiated (Breakout).

### ATTENUATOR DIMENSIONS (mm), DYNAMIC INSERTION LOSS (dB) & WEIGHTS (kg)

Attenuator Code	Attenuator Dimensions			Air path	Dynamic Insertion Loss (dB)								Attenuator Weight (kg)	Packed Weight (kg)
	Length	Width	Height		63	125	250	500	1000	2000	4000	8000		
XBC15-HS-MS10	1050	351	218	S / D	5	11	12	19	27	28	24	19	33	38
XBC15-HE-MS10	1050	242	218	I / E	2	2	3	10	17	10	6	3	29	32
XBC15-HS-MS12	1250	351	218	S / D	7	13	16	26	35	34	27	21	40	45
XBC15-HE-MS12	1250	242	218	I / E	4	4	7	17	25	16	9	5	34	37
XBC15-HS-MS16	1600	351	218	S / D	9	15	20	33	41	40	30	23	49	54
XBC15-HE-MS16	1600	242	218	I / E	6	6	11	24	31	22	12	7	42	45

S / D = Supply / Discharge I / E = Intake / Extract. Coding: The S / D denotes the type of silencer required for the supply or discharge. The I / E denotes the type of silencer required for the extract or fresh air intake on the unit. All XBC matched silencers are double skinned.

### COUNTERFLOW HEAT EXCHANGER EFFICIENCY (%)

Performance based on:  
Indoor Conditions 21 Deg C / 50 % RH

#### Key to performance curves

- Intake Temperature (Deg C)
- 5 Deg C Intake Typically Specified Values
- 3 Deg C Intake Typically Specified Values
- 1 Deg C Intake Typically Specified Values
- 6 Deg C Approx. Average outdoor temperature (UK heating season)

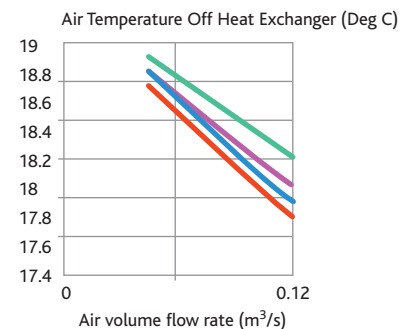
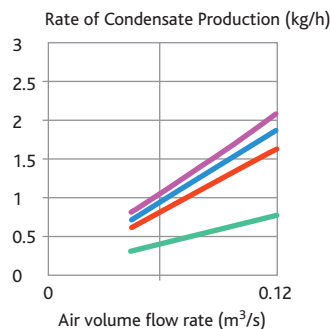
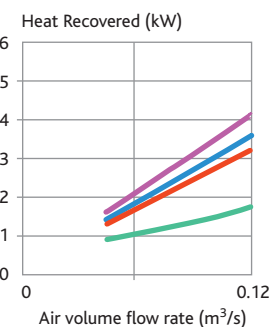
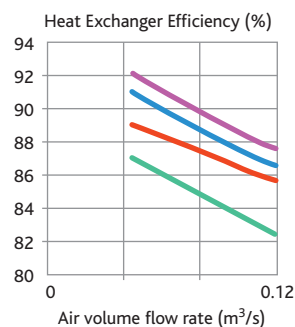

### HEATING COIL DATA LPHW

LPHW Deg C	Airflow (m³/s)	Output (kW)	Air Off Temp (C*)	Water flow (l/s)	Coil ΔP (kPa)	Pipe Connection (mm)	Valve ΔP (kPa)	Valve Type
LPHW 82/71	0.09	3.0	38	0.07	1.0	15	1.4	4 Port
LPHW 80/60	0.09	2.3	32	0.03	0.2	15	0.5	4 Port
LPHW 60/40	0.09	1.3	22	0.02	0.1	15	0.5	4 Port

\*Nb Limited to 30 Deg C for Ecosmart Units. Data based on 10 Deg C Air On temperature.

# XBC15 HORIZONTAL HEAT EXCHANGE UNITS

## PERFORMANCE & TECHNICAL INFORMATION

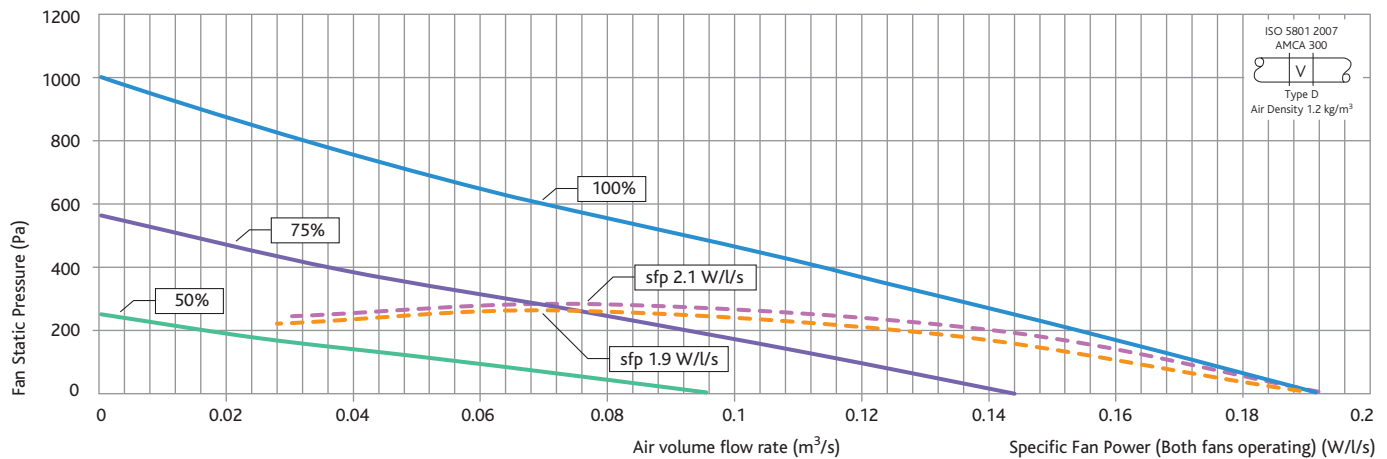

### XBC15 UNIT PERFORMANCE - EXAMPLE 0.1m<sup>3</sup>/s @ 100Pa = SFP 1.1, 17dBA @ 3m

Fan Speed	External Static Pressure (Pa)	Fan Speed									Fan Speed	External Static Pressure (Pa)					
		0	50	100	200	300	400	500	600	700			0	50	100	200	300
100%	Airflow (m <sup>3</sup> /s)	0.19	0.18	0.17	0.15	0.13	0.11	0.09	0.07	0.05	50%	Airflow (m <sup>3</sup> /s)	0.10	0.08	0.06	0.02	
	sfp (W/l/s)	1.80	1.82	1.88	2.13	2.55	3.15	3.92	4.87	5.99		sfp (W/l/s)	0.45	0.53	0.79	1.82	
	dBA@3m	26										dBA@3m	< 20				
75%	Airflow (m <sup>3</sup> /s)	0.14	0.13	0.12	0.09	0.06	0.04	0.01					25%	Airflow (m <sup>3</sup> /s)	0.05	0.01	
	sfp (W/l/s)	1.01	1.05	1.16	1.61	2.37	3.45	4.83						sfp (W/l/s)	0.11	0.46	
	dBA@3m	20									dBA@3m	< 20					

Specific Fan Power figures are the total for both fans operating.

For accurate figures, please refer to Nuair Fan Selection Programme at [www.nuair.co.uk](http://www.nuair.co.uk)

Unit Code	Voltage / Phase / Frequency	Input Power (W)	FLC / SC (A)	Max Operating Temperature	Fan Speed (rpm)	Unit Weight (kg)	Packed Weight (kg)	Pallet / crate dimensions (mm)
XBC15-H-L**	230 / 1 / 50	340	2.8 / 2.8	40°C	4000	187	237	1850L x 1400W x 505H
XBC15-H-E**	230 / 1 / 50	3340*	16 / 16	40°C	4000	195	245	1850L x 1400W x 505H
XBC15-H-N**	230 / 1 / 50	340	2.8 / 2.8	40°C	4000	183	233	1850L x 1400W x 505H

\*\*Add relevant code ie: BC, ES, CO or AT for control type. \*Includes 3kW Electric Heater.

### FAN UNIT DIMENSIONS (mm)

Note: All models (BC, ES, CO or AT) have a fold down (90°) pivoting control box for easy commissioning.

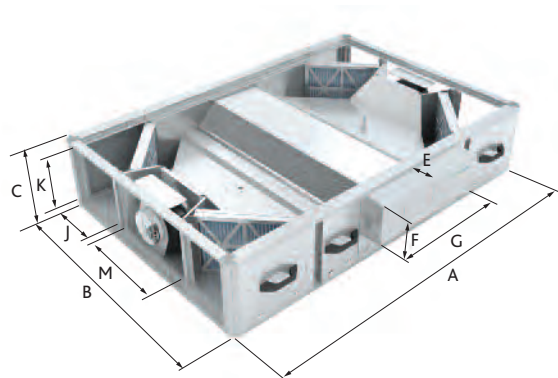

### XBC15 FAN CONFIGURATION

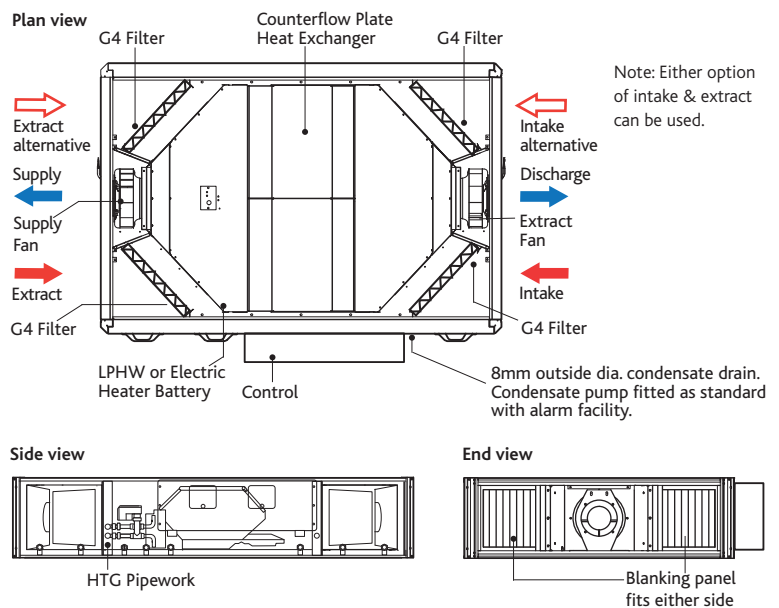

Fan Unit Dimensions (mm)			Control for all Models Dimensions (mm)			Rectangular Aperture Dimensions (mm)			Weather Roof for all Models Code XBC15-H-WP			Service & Maintenance Requirements	
A	B	C	E	F	G	J	K	M	H	x	W		x
1600	1000	260	120	200	670	242	218	351	65	1000	1600	The unit is designed for side access as standard and must be installed with a minimum of 260mm clearance from a wall or barrier. This will provide access to filters, coil, fan, heat exchanger, condensate tray and pump.	

2 attenuator flanges are attached to every unit. Add 50mm to dimension 'A' to include both flanges. Weather roof is separate code and can be retro fitted on site.

# XBC15 HORIZONTAL HEAT EXCHANGE UNITS

## PERFORMANCE & TECHNICAL INFORMATION

### XBC15 FAN - SOUND DATA

Fan Speed	Sound Power Levels (dB re 1 pW)	Frequency (Hz)								Spherical dBA@3m	Fan Speed	External Static Pressure (Pa)								Spherical dBA@3m
		63	125	250	500	1000	2000	4000	8000			63	125	250	500	1000	2000	4000	8000	
100%	Induct Intake	70	60	55	56	62	55	47	43	26	50%	55	45	40	41	47	40	32	28	<20
	Induct Supply	75	72	65	66	68	64	59	57			60	57	50	51	53	49	44	42	
	Induct Discharge	75	73	65	67	68	65	60	58			60	58	50	52	53	50	45	43	
	Induct Extract	69	59	55	55	61	55	45	41			54	44	40	40	46	40	30	26	
	Casing Radiated	61	57	42	43	41	37	34	23			46	42	27	28	26	22	>20	>20	
75%	Induct Intake	64	54	49	50	56	49	41	37	20	25%	40	30	25	26	32	25	17	13	<20
	Induct Supply	69	66	59	60	62	58	53	51			45	42	35	36	38	34	29	27	
	Induct Discharge	69	67	59	61	62	59	54	52			45	43	35	37	38	35	30	28	
	Induct Extract	63	53	49	49	55	49	39	35			39	29	25	25	31	25	>20	>20	
	Casing Radiated	55	51	36	37	35	31	28	>20			31	27	>20	>20	>20	>20	>20	>20	

\*Casing Radiated (Breakout).

### ATTENUATOR DIMENSIONS (mm), DYNAMIC INSERTION LOSS (dB) & WEIGHTS (kg)

Attenuator Code	Attenuator Dimensions			Air path	Dynamic Insertion Loss (dB)								Attenuator Weight (kg)	Packed Weight (kg)
	Length	Width	Height		63	125	250	500	1000	2000	4000	8000		
XBC15-HS-MS10	1050	351	218	S / D	5	11	12	19	27	28	24	19	33	38
XBC15-HE-MS10	1050	242	218	I / E	2	2	3	10	17	10	6	3	29	32
XBC15-HS-MS12	1250	351	218	S / D	7	13	16	26	35	34	27	21	40	45
XBC15-HE-MS12	1250	242	218	I / E	4	4	7	17	25	16	9	5	34	37
XBC15-HS-MS16	1600	351	218	S / D	9	15	20	33	41	40	30	23	49	54
XBC15-HE-MS16	1600	242	218	I / E	6	6	11	24	31	22	12	7	42	45

S / D = Supply / Discharge I / E = Intake / Extract. Coding: The S / D denotes the type of silencer required for the supply or discharge. The I / E denotes the type of silencer required for the extract or fresh air intake on the unit. All XBC matched silencers are double skinned.

### COUNTERFLOW HEAT EXCHANGER EFFICIENCY (%)

Performance based on:  
Indoor Conditions 21 Deg C / 50 % RH

#### Key to performance curves

- Intake Temperature (Deg C)
- 5 Deg C Intake Typically Specified Values
- 3 Deg C Intake Typically Specified Values
- 1 Deg C Intake Typically Specified Values
- 6 Deg C Approx. Average outdoor temperature (UK heating season)

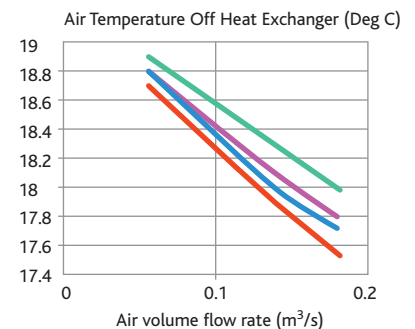
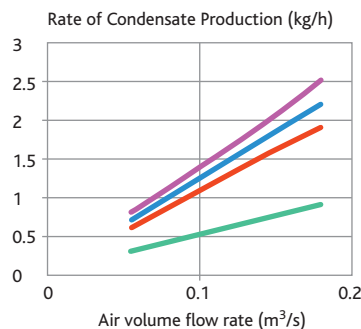
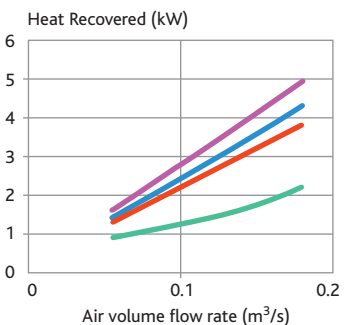
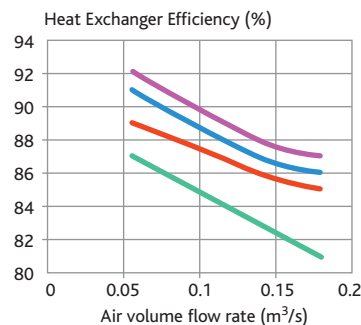

### HEATING COIL DATA LPHW

LPHW Deg C	Airflow (m³/s)	Output (kW)	Air Off Temp (C*)	Water flow (l/s)	Coil ΔP (kPa)	Pipe Connection (mm)	Valve ΔP (kPa)	Valve Type
LPHW 82/71	0.17	4.1	30	0.09	1.8	15	2.5	4 Port
	0.13	3.9	35	0.08	1.6	15	2.2	
	0.09	3.0	38	0.07	1.0	15	1.4	
LPHW 80/60	0.17	3.3	26	0.04	0.4	15	1	4 Port
	0.13	3.0	29	0.04	0.3	15	0.9	
	0.09	2.3	32	0.03	0.2	15	0.5	
LPHW 60/40	0.17	1.9	19	0.02	0.1	15	1	4 Port
	0.13	1.7	21	0.02	0.1	15	0.8	
	0.09	1.3	22	0.02	0.1	15	0.5	

\*Nb Limited to 30 Deg C for Ecosmart Units. Data based on 10 Deg C Air On temperature.

# XBC25 HORIZONTAL HEAT EXCHANGE UNITS

## PERFORMANCE & TECHNICAL INFORMATION

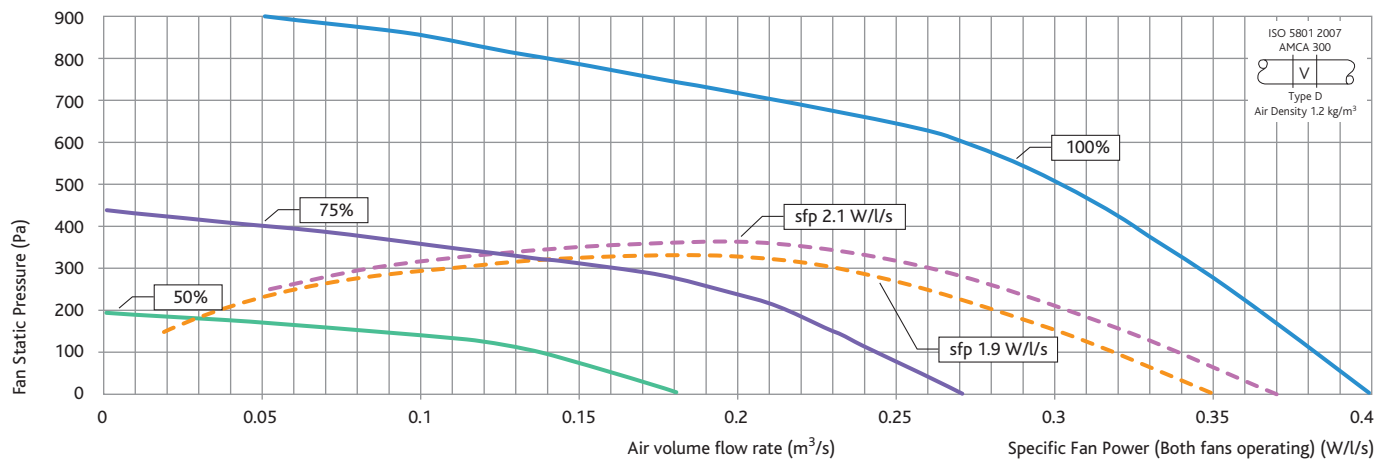

### XBC25 UNIT PERFORMANCE - EXAMPLE 0.2m<sup>3</sup>/s @ 150Pa = SFP 1.1, 29dBA @ 3m

Fan Speed	External Static Pressure (Pa)	External Static Pressure (Pa)								Fan Speed	External Static Pressure (Pa)	External Static Pressure (Pa)							
		0	50	100	200	300	400	500	600			700	0	50	100	200	300	400	500
100%	Airflow (m <sup>3</sup> /s)	0.36	0.35	0.34	0.32	0.30	0.27	0.24	0.17	50%	Airflow (m <sup>3</sup> /s)	0.18	0.16	0.14	25%	Airflow (m <sup>3</sup> /s)	0.09		
	sfp (W/l/s)	2.00	2.10	2.15	2.28	2.46	2.59	2.90	3.80		sfp (W/l/s)	0.5	0.57	0.65		sfp (W/l/s)	0.2		
	dBA@3m	37	dBA@3m	25	dBA@3m	< 20													
75%	Airflow (m <sup>3</sup> /s)	0.27	0.26	0.24	0.21	0.16	0.05	25%	sfp (W/l/s)	1.1	1.2	1.3	1.4	1.7	4	dBA@3m	< 20		
	sfp (W/l/s)	1.1	1.2	1.3	1.4	1.7	4		dBA@3m	< 20									
	dBA@3m	31																	

Specific Fan Power figures are the total for both fans operating.

For accurate figures, please refer to Nuair Fan Selection Programme at [www.nuair.co.uk](http://www.nuair.co.uk)

Unit Code	Voltage / Phase / Frequency	Input Power (W)	FLC / SC (A)	Max Operating Temperature	Fan Speed (rpm)	Unit Weight (kg)	Packed Weight (kg)	Pallet / crate dimensions (mm)
XBC25-H-L**	230 / 1 / 50	1000	6.4 / 6.4	40°C	4000	235	285	1850L x 1400W x 505H
XBC25-H-E**	230 / 1 / 50	5500*	19.4 / 19.4	40°C	4000	242	292	1850L x 1400W x 505H
XBC25-H-N**	230 / 1 / 50	1000	6.4 / 6.4	40°C	4000	231	281	1850L x 1400W x 505H

\*\*Add relevant code ie: BC, ES, CO or AT for control type. \*Includes 4.5kW Electric Heater.

### FAN UNIT DIMENSIONS (mm)

Note: All models (BC, ES, CO or AT) have a fold down (90°) pivoting control box for easy commissioning.

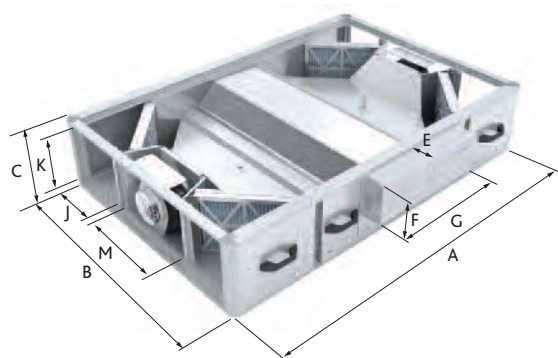

### XBC25 FAN CONFIGURATION

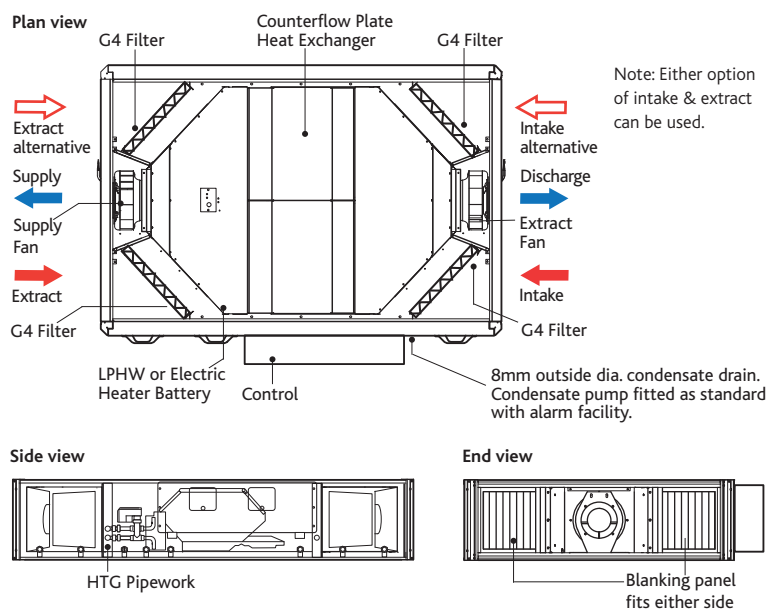

Fan Unit Dimensions (mm)			Control for all Models Dimensions (mm)			Rectangular Aperture Dimensions (mm)			Weather Roof for all Models Code XBC25-H-WP			Service & Maintenance Requirements	
A	B	C	E	F	G	J	K	M	H	x	W		x
1700	1150	340	120	200	670	262	298	481	75	x	1150	x	1700

The unit is designed for side access as standard and must be installed with a minimum of 260mm clearance from a wall or barrier. This will provide access to filters, coil, fan, heat exchanger, condensate tray and pump.

2 attenuator flanges are attached to every unit. Add 50mm to dimension 'A' to include both flanges. Weather roof is separate code and can be retro fitted on site.

# XBC25 HORIZONTAL HEAT EXCHANGE UNITS

## PERFORMANCE & TECHNICAL INFORMATION

### XBC25 FAN - SOUND DATA

Fan Speed	Sound Power Levels (dB re 1 pW)	Frequency (Hz)								Spherical dBA@3m	Fan Speed	External Static Pressure (Pa)								Spherical dBA@3m
		63	125	250	500	1000	2000	4000	8000			63	125	250	500	1000	2000	4000	8000	
100%	Induct Intake	77	71	69	71	66	62	54	53	37	50%	63	57	55	57	52	48	40	39	23
	Induct Supply	82	83	78	82	72	72	68	70			68	69	64	68	58	58	54	56	
	Induct Discharge	83	84	78	81	72	72	70	71			69	70	64	67	58	58	56	57	
	Induct Extract	76	70	68	71	65	62	54	54			62	56	54	57	51	48	40	40	
	Casing Radiated	69	68	55	58	45	44	44	36			55	54	41	44	31	30	30	22	
75%	Induct Intake	71	65	63	65	60	56	48	47	31	25%	48	42	40	42	37	33	25	24	< 20
	Induct Supply	76	77	72	76	66	66	62	64			53	54	49	53	43	43	39	41	
	Induct Discharge	77	78	72	75	66	66	64	65			54	55	49	52	43	43	41	42	
	Induct Extract	70	64	62	65	59	56	48	48			47	41	39	42	36	33	25	25	
	Casing Radiated	63	62	49	52	39	38	38	30			40	39	26	29	< 20	< 20	< 20	< 20	

\*Casing Radiated (Breakout).

### ATTENUATOR DIMENSIONS (mm), DYNAMIC INSERTION LOSS (dB) & WEIGHTS (kg)

Attenuator Code	Attenuator Dimensions			Air path	Dynamic Insertion Loss (dB)								Attenuator Weight (kg)	Packed Weight (kg)
	Length	Width	Height		63	125	250	500	1000	2000	4000	8000		
XBC25-HS-MS10	1050	481	298	S / D	5	8	15	30	41	31	21	16	42	47
XBC25-HE-MS10	1050	262	298	I / E	4	4	10	22	26	15	10	8	33	36
XBC25-HS-MS12	1250	481	298	S / D	7	10	18	36	51	39	26	20	51	56
XBC25-HE-MS12	1250	262	298	I / E	5	6	12	27	34	20	13	9	40	43
XBC25-HS-MS16	1600	481	298	S / D	9	13	23	42	55	49	32	25	64	69
XBC25-HE-MS16	1600	262	298	I / E	6	8	15	33	43	25	15	11	50	53

S / D = Supply / Discharge I / E = Intake / Extract. Coding: The S / D denotes the type of silencer required for the supply or discharge. The I / E denotes the type of silencer required for the extract or fresh air intake on the unit. All XBC matched silencers are double skinned.

### COUNTERFLOW HEAT EXCHANGER EFFICIENCY (%)

Performance based on:  
Indoor Conditions 21 Deg C / 50 % RH

#### Key to performance curves

- Intake Temperature (Deg C)
- 5 Deg C Intake Typically Specified Values
- 3 Deg C Intake Typically Specified Values
- 1 Deg C Intake Typically Specified Values
- 6 Deg C Approx. Average outdoor temperature (UK heating season)

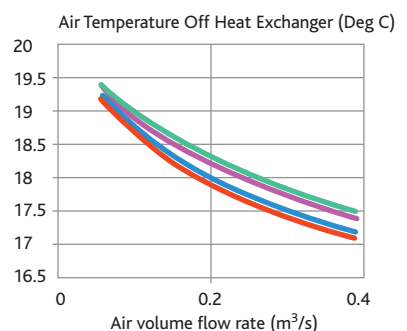
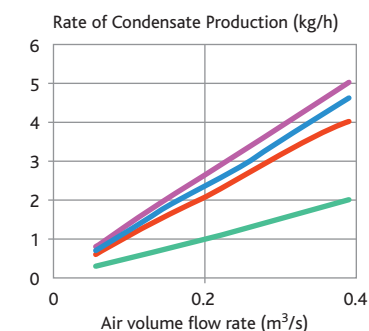
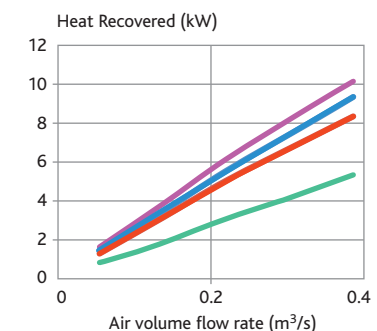
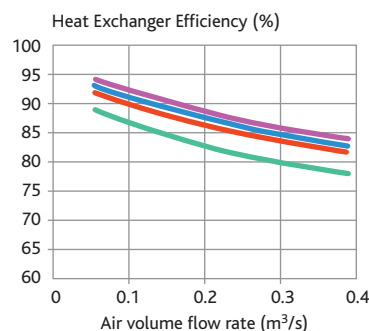

### HEATING COIL DATA LPHW

LPHW Deg C	Airflow (m³/s)	Output (kW)	Air Off Temp (C*)	Water flow (l/s)	Coil ΔP (kPa)	Pipe Connection (mm)	Valve ΔP (kPa)	Valve Type
LPHW 82/71	0.25	6.0	30	0.13	7.3	15	9	4 Port
	0.1875	5.6	35	0.13	6.5	15	8.0	
	0.125	4.4	40	0.10	4.0	15	4.9	
LPHW 80/60	0.25	4.8	26	0.06	1.4	15	2	4 Port
	0.1875	4.3	29	0.05	1.3	15	1.8	
	0.125	3.4	33	0.04	0.8	15	1.1	
LPHW 60/40	0.25	2.8	19	0.03	0.5	15	1	4 Port
	0.1875	2.6	21	0.03	0.4	15	0.8	
	0.125	2.0	23	0.02	0.3	15	0.5	

\*Nb Limited to 30 Deg C for Ecosmart Units. Data based on 10 Deg C Air On temperature.

# XBC45 HORIZONTAL HEAT EXCHANGE UNITS

## PERFORMANCE & TECHNICAL INFORMATION

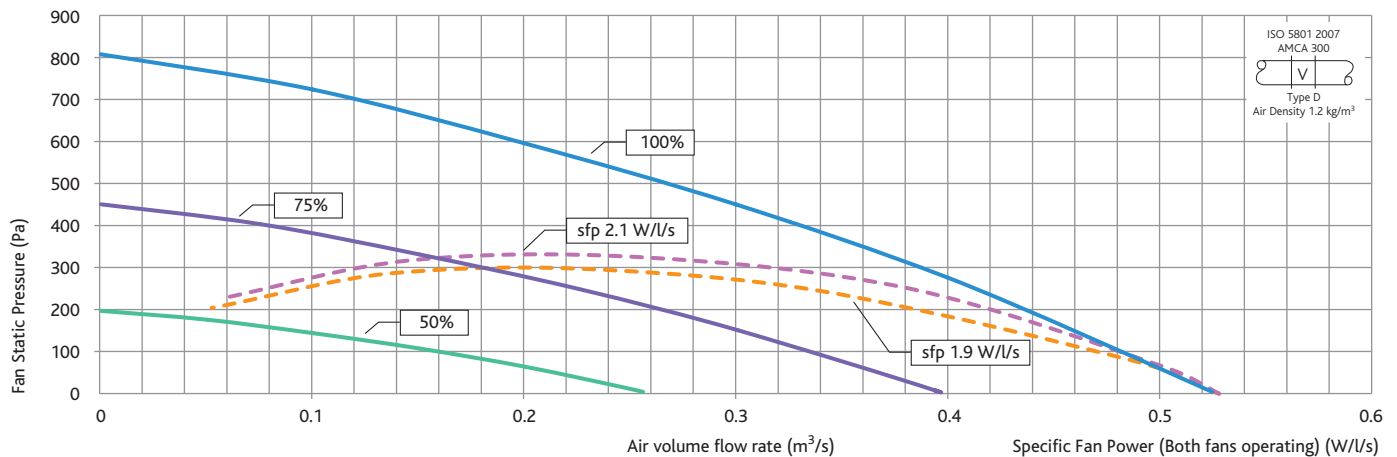

### XBC45 UNIT PERFORMANCE - EXAMPLE 0.256m³/s @ 150Pa = SFP 1.1, 27dBA @ 3m

Fan Speed		External Static Pressure (Pa)									Fan Speed		External Static Pressure (Pa)								
		0	50	100	200	300	400	500	600	700			0	50	100	200	300	400	500	600	700
100%	Airflow (m³/s)	0.53	0.50	0.48	0.44	0.39	0.33	0.27	0.20	0.12	50%	Airflow (m³/s)	0.26	0.22	0.17	0.01	25%	Airflow (m³/s)	0.13	0.00	
	sfp (W/l/s)	1.75	1.83	1.95	2.21	2.42	2.64	3.04	3.95	sfp (W/l/s)		0.44	0.55	0.66	2.35	sfp (W/l/s)		0.11	0.59		
	dBA@3m	35										dBA@3m	20					dBA@3m	< 20		
75%	Airflow (m³/s)	0.39	0.37	0.34	0.27	0.19	0.08	25%	Airflow (m³/s)	0.13	0.00										
	sfp (W/l/s)	0.98	1.08	1.21	1.43	1.85	3.51		sfp (W/l/s)	0.11	0.59										
	dBA@3m	29									dBA@3m	< 20									

Specific Fan Power figures are the total for both fans operating.

For accurate figures, please refer to Nuair Fan Selection Programme at [www.nuair.co.uk](http://www.nuair.co.uk)

Unit Code	Voltage / Phase / Frequency	Input Power (W)	FLC / SC (A)	Max Operating Temperature	Fan Speed (rpm)	Unit Weight (kg)	Packed Weight (kg)	Pallet / crate dimensions (mm)
XBC45-H-L**	230 / 1 / 50	1100	6.9 / 6.9	40°C	2400	291	391	2150L x 1800W x 650H
XBC45-H-E**	230 / 1 / 50	5600*	27 / 27	40°C	2400	298	398	2150L x 1800W x 650H
XBC45-H-N**	230 / 1 / 50	1100	6.9 / 6.9	40°C	2400	287	387	2150L x 1800W x 650H

\*\*Add relevant code ie: BC, ES, CO or AT for control type. \*Includes 4.5kW Electric Heater.

### FAN UNIT DIMENSIONS (mm)

Note: All models (BC, ES, CO or AT) have a fold down (90°) pivoting control box for easy commissioning.

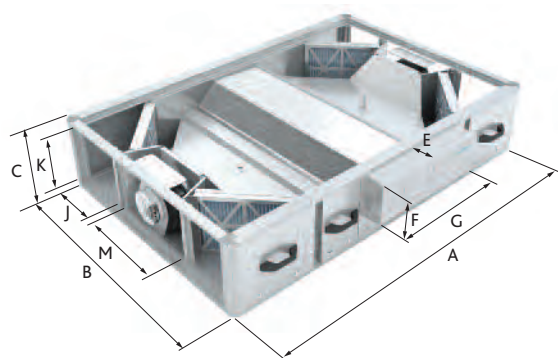

### XBC45 FAN CONFIGURATION

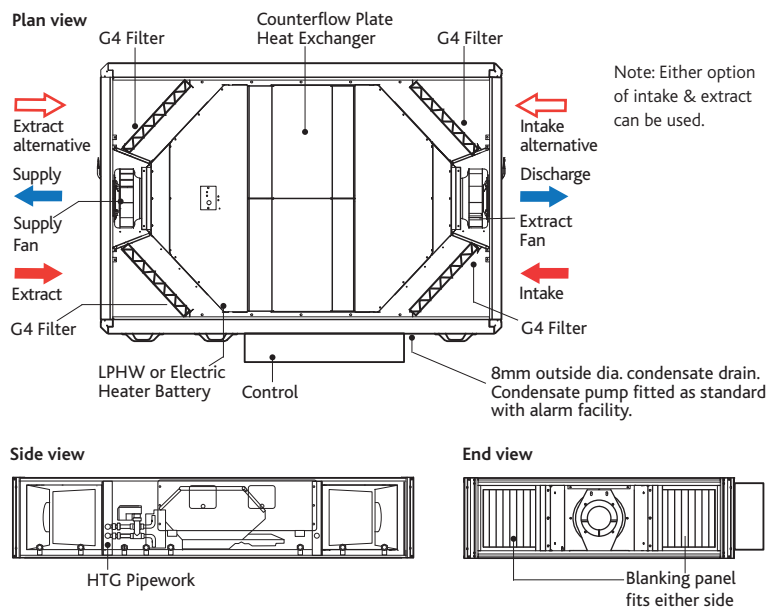

Fan Unit Dimensions (mm)			Control for all Models Dimensions (mm)			Rectangular Aperture Dimensions (mm)			Weather Roof for all Models Code XBC45-H-WP			Service & Maintenance Requirements		
A	B	C	E	F	G	J	K	M	H	x	W	x	L	
1900	1250	400	120	200	670	275	358	536	85	1250	1900	The unit is designed for side access as standard and must be installed with a minimum of 260mm clearance from a wall or barrier. This will provide access to filters, coil, fan, heat exchanger, condensate tray and pump.		

2 attenuator flanges are attached to every unit. Add 50mm to dimension 'A' to include both flanges. Weather roof is separate code and can be retro fitted on site.

# XBC45 HORIZONTAL HEAT EXCHANGE UNITS

## PERFORMANCE & TECHNICAL INFORMATION

### XBC45 FAN - SOUND DATA

Fan Speed	Sound Power Levels (dB re 1 pW)	Frequency (Hz)								Spherical dBA@3m	Fan Speed	External Static Pressure (Pa)								Spherical dBA@3m
		63	125	250	500	1000	2000	4000	8000			63	125	250	500	1000	2000	4000	8000	
100%	Induct Intake	83	75	75	64	64	62	54	45	35	50%	68	60	60	49	49	47	39	30	20
	Induct Supply	87	80	85	71	72	71	66	62			72	65	70	56	57	56	51	47	
	Induct Discharge	88	81	85	71	72	72	66	64			73	66	70	56	57	57	51	49	
	Induct Extract	84	75	76	63	64	63	53	44			69	60	61	48	49	48	38	29	
	Casing Radiated	74	65	62	47	45	44	40	29			59	50	47	32	30	29	25	< 20	
75%	Induct Intake	77	69	69	58	58	56	48	39	29	25%	53	45	45	34	34	32	24	< 20	< 20
	Induct Supply	81	74	79	65	66	65	60	56			57	50	55	41	42	41	36	32	
	Induct Discharge	82	75	79	65	66	66	60	58			58	51	55	41	42	42	36	34	
	Induct Extract	78	69	70	57	58	57	47	38			54	45	46	33	34	33	23	< 20	
	Casing Radiated	68	59	56	41	39	38	34	23			44	35	32	< 20	< 20	< 20	< 20	< 20	

\*Casing Radiated (Breakout).

### ATTENUATOR DIMENSIONS (mm), DYNAMIC INSERTION LOSS (dB) & WEIGHTS (kg)

Attenuator Code	Attenuator Dimensions			Air path	Dynamic Insertion Loss (dB)								Attenuator Weight (kg)	Packed Weight (kg)
	Length	Width	Height		63	125	250	500	1000	2000	4000	8000		
XBC45-HS-MS10	1050	536	358	S / D	5	9	16	13	11	8	7	6	48	53
XBC45-HE-MS10	1050	275	358	I / E	3	5	11	13	15	11	6	4	37	40
XBC45-HS-MS12	1250	536	358	S / D	7	11	20	20	19	14	10	8	59	64
XBC45-HE-MS12	1250	275	358	I / E	5	7	15	20	23	17	9	6	45	48
XBC45-HS-MS16	1600	536	358	S / D	9	13	24	27	25	20	13	10	73	78
XBC45-HE-MS16	1600	275	358	I / E	7	9	19	27	29	23	12	8	56	59

S / D = Supply / Discharge I / E = Intake / Extract. Coding: The S / D denotes the type of silencer required for the supply or discharge. The I / E denotes the type of silencer required for the extract or fresh air intake on the unit. All XBC matched silencers are double skinned.

### COUNTERFLOW HEAT EXCHANGER EFFICIENCY (%)

Performance based on:  
Indoor Conditions 21 Deg C / 50 % RH

#### Key to performance curves

- Intake Temperature (Deg C)
- 5 Deg C Intake Typically Specified Values
- 3 Deg C Intake Typically Specified Values
- 1 Deg C Intake Typically Specified Values
- 6 Deg C Approx. Average outdoor temperature (UK heating season)

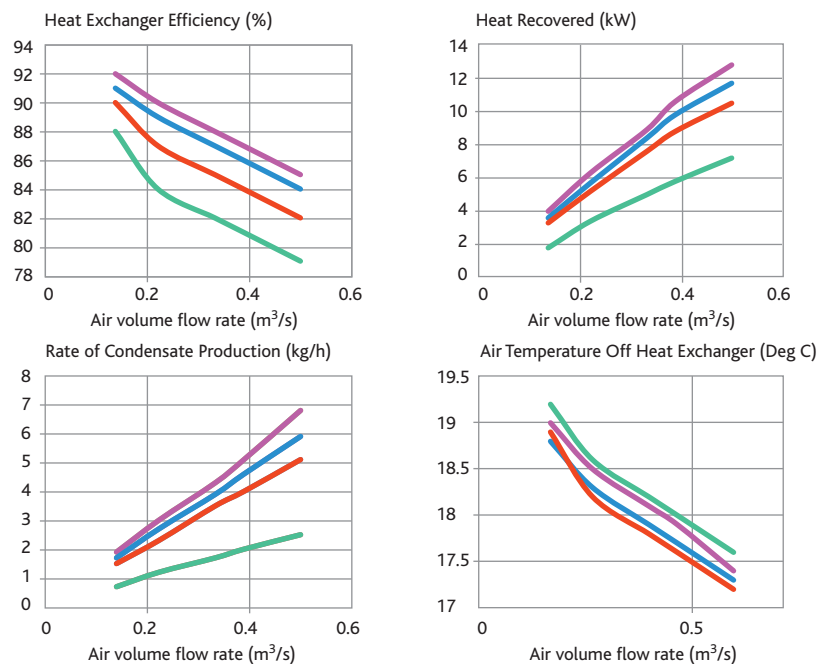

### HEATING COIL DATA LPHW

LPHW Deg C	Airflow (m³/s)	Output (kW)	Air Off Temp (C*)	Water flow (l/s)	Coil ΔP (kPa)	Pipe Connection (mm)	Valve ΔP (kPa)	Valve Type
LPHW 82/71	0.37	8.9	30	0.20	16.0	15	16	4 Port
	0.2775	8.4	35	0.19	14.1	15	14.1	
	0.185	6.6	40	0.15	8.8	15	8.8	
LPHW 80/60	0.37	7.2	26	0.09	3.2	15	3	4 Port
	0.2775	6.5	29	0.08	2.8	15	2.7	
	0.185	5.1	33	0.06	1.8	15	1.6	
LPHW 60/40	0.37	4.2	19	0.05	1.0	15	1	4 Port
	0.2775	3.9	22	0.05	0.8	15	0.8	
	0.185	3.0	23	0.04	0.5	15	0.5	

\*Nb Limited to 30 Deg C for Ecosmart Units. Data based on 10 Deg C Air On temperature.

# XBC55 HORIZONTAL HEAT EXCHANGE UNITS

## PERFORMANCE & TECHNICAL INFORMATION

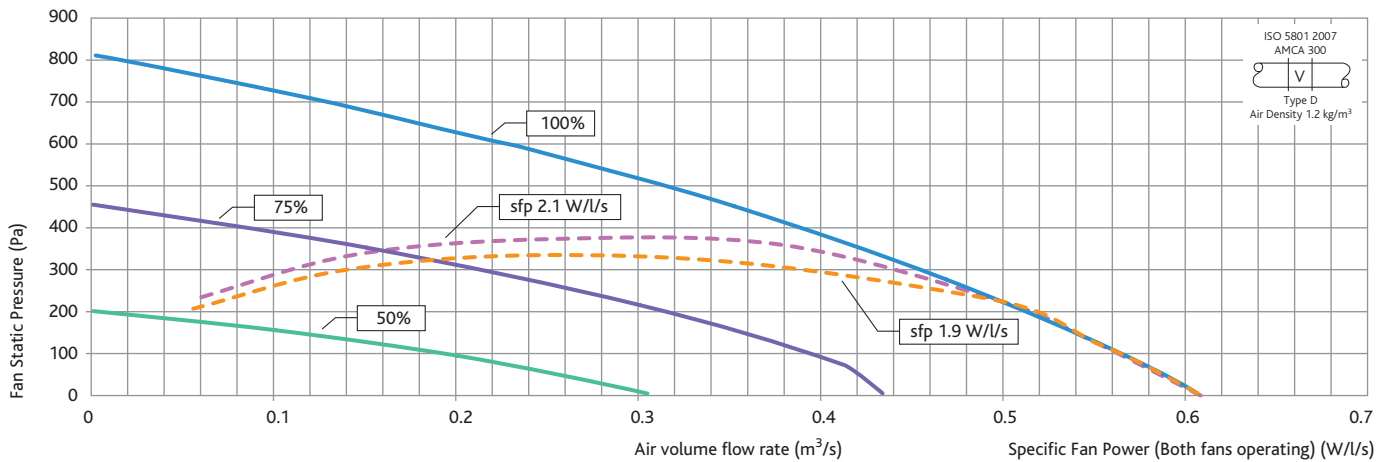

**XBC55 UNIT PERFORMANCE - EXAMPLE 0.38m³/s @ 150Pa = SFP 1.2, 29dBA @ 3m**

Fan Speed		External Static Pressure (Pa)									Fan Speed		External Static Pressure (Pa)								
		0	50	100	200	300	400	500	600	700			0	50	100	200	300	400	500	600	700
100%	Airflow (m³/s)	0.61	0.59	0.57	0.51	0.46	0.39	0.31	0.23	0.13	50%	Airflow (m³/s)	0.31	0.26	0.20	0.01	25%	Airflow (m³/s)	0.15	0.00	
	sfp (W/l/s)	1.60	1.64	1.69	1.82	2.03	2.38	2.91	3.67	4.71		sfp (W/l/s)	0.40	0.45	0.59	1.52		sfp (W/l/s)	0.10	0.38	
	dBA@3m	35										dBA@3m	20					dBA@3m	< 20		
75%	Airflow (m³/s)	0.46	0.43	0.39	0.32	0.21	0.09	50%	Airflow (m³/s)	0.15	0.00										
	sfp (W/l/s)	0.90	0.95	1.00	1.24	1.76	2.72		sfp (W/l/s)	0.10	0.38										
	dBA@3m	28									dBA@3m	< 20									

Specific Fan Power figures are the total for both fans operating.

For accurate figures, please refer to Nuair Fan Selection Programme at [www.nuair.co.uk](http://www.nuair.co.uk)

Unit Code	Voltage / Phase / Frequency	Input Power (W)	FLC / SC (A)	Max Operating Temperature	Fan Speed (rpm)	Unit Weight (kg)	Packed Weight (kg)	Pallet / crate dimensions (mm)
XBC55-H-L**	230 / 1 / 50	1100	6.9 / 6.9	40°C	2400	368	468	2150L x 1500W x 650H
XBC55-H-E**	230 / 1 / 50	10100*	46 / 46	40°C	2400	375	475	2150L x 1500W x 650H
XBC55-H-N**	230 / 1 / 50	1100	6.9 / 6.9	40°C	2400	364	464	2150L x 1500W x 650H

\*\*Add relevant code ie: BC, ES, CO or AT for control type. \*Includes 9kW Electric Heater.

### FAN UNIT DIMENSIONS (mm)

Note: All models (BC, ES, CO or AT) have a fold down (90°) pivoting control box for easy commissioning.

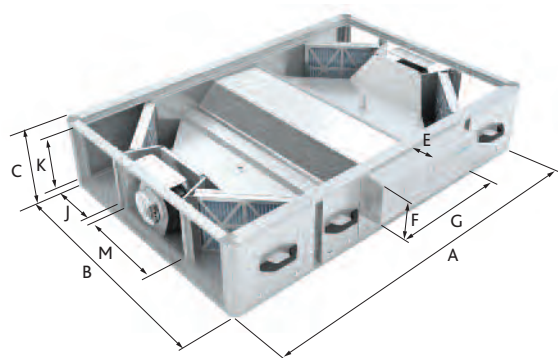

### XBC55 FAN CONFIGURATION

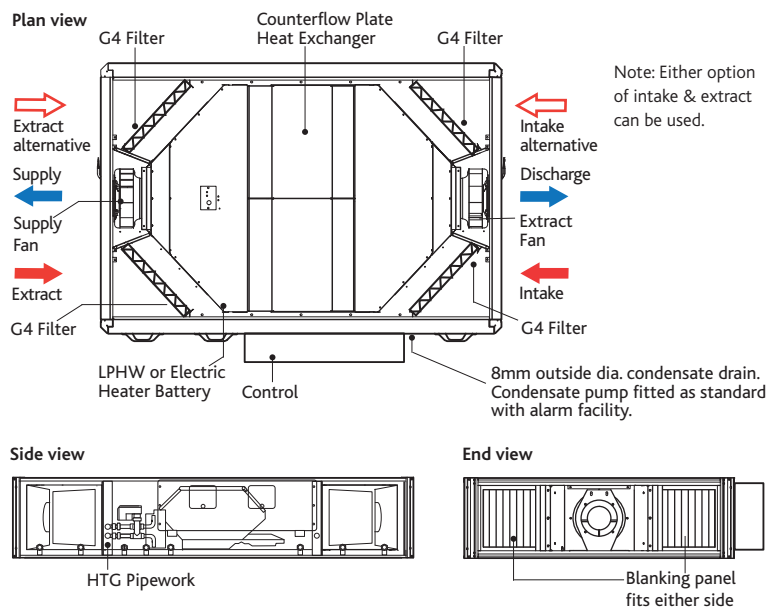

Fan Unit Dimensions (mm)			Control for all Models Dimensions (mm)			Rectangular Aperture Dimensions (mm)			Weather Roof for all Models Code XBC10-H-WP			Service & Maintenance Requirements		
A	B	C	E	F	G	J	K	M	H	x	W	x	L	
1900	1560	470	120	200	670	402	428	592	95	1560	1900	The unit is designed for side access as standard and must be installed with a minimum of 260mm clearance from a wall or barrier. This will provide access to filters, coil, fan, heat exchanger, condensate tray and pump.		

2 attenuator flanges are attached to every unit. Add 50mm to dimension 'A' to include both flanges. Weather roof is separate code and can be retro fitted on site.



# XBC55 HORIZONTAL HEAT EXCHANGE UNITS

## PERFORMANCE & TECHNICAL INFORMATION

### XBC55 FAN - SOUND DATA

Fan Speed	Sound Power Levels (dB re 1 pW)	Frequency (Hz)								Spherical dBA@3m	Fan Speed	External Static Pressure (Pa)								Spherical dBA@3m
		63	125	250	500	1000	2000	4000	8000			63	125	250	500	1000	2000	4000	8000	
100%	Induct Intake	81	74	75	63	64	61	53	41	35	50%	66	59	60	48	49	46	38	26	20
	Induct Supply	85	80	84	71	72	70	66	61			70	65	69	56	57	55	51	46	
	Induct Discharge	86	81	84	71	72	71	66	63			71	66	69	56	57	56	51	48	
	Induct Extract	82	75	75	63	64	62	53	43			67	60	60	48	49	47	38	28	
	Casing Radiated	72	65	61	47	45	43	40	28			57	50	46	32	30	28	25	13	
75%	Induct Intake	75	68	69	57	58	55	47	35	28	25%	51	44	45	33	34	31	23	< 20	<20
	Induct Supply	79	74	78	65	66	64	60	55			55	50	54	41	42	40	36	31	
	Induct Discharge	80	75	78	65	66	65	60	57			56	51	54	41	42	41	36	33	
	Induct Extract	76	69	69	57	58	56	47	37			52	45	45	33	34	32	23	< 20	
	Casing Radiated	66	59	55	41	39	37	34	22			42	35	31	<20	<20	<20	<20	<20	

\*Casing Radiated (Breakout).

### ATTENUATOR DIMENSIONS (mm), DYNAMIC INSERTION LOSS (dB) & WEIGHTS (kg)

Attenuator Code	Attenuator Dimensions			Air path	Dynamic Insertion Loss (dB)								Attenuator Weight (kg)	Packed Weight (kg)
	Length	Width	Height		63	125	250	500	1000	2000	4000	8000		
XBC55-HS-MS10	1050	592	428	S / D	4	10	17	19	23	18	15	11	54	59
XBC55-HE-MS10	1050	402	428	I / E	3	6	12	15	15	11	6	4	47	50
XBC55-HS-MS12	1250	592	428	S / D	6	12	21	26	31	24	18	13	67	72
XBC55-HE-MS12	1250	402	428	I / E	5	8	16	22	23	17	9	6	57	60
XBC55-HS-MS16	1600	592	428	S / D	8	14	25	33	37	30	21	15	84	89
XBC55-HE-MS16	1600	402	428	I / E	7	10	20	29	29	23	12	8	71	74

S / D = Supply / Discharge I / E = Intake / Extract. Coding: The S / D denotes the type of silencer required for the supply or discharge. The I / E denotes the type of silencer required for the extract or fresh air intake on the unit. All XBC matched silencers are double skinned.

### COUNTERFLOW HEAT EXCHANGER EFFICIENCY (%)

Performance based on:  
Indoor Conditions 21 Deg C / 50 % RH

#### Key to performance curves

- Intake Temperature (Deg C)
- 5 Deg C Intake Typically Specified Values
- 3 Deg C Intake Typically Specified Values
- 1 Deg C Intake Typically Specified Values
- 6 Deg C Approx. Average outdoor temperature (UK heating season)

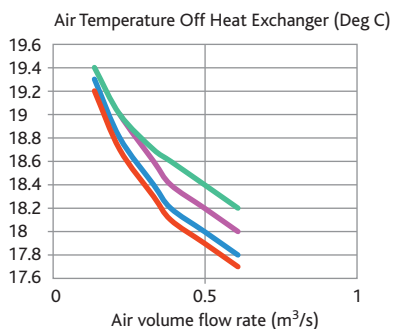
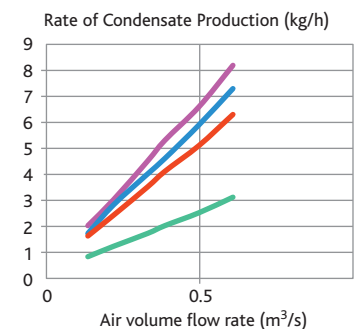
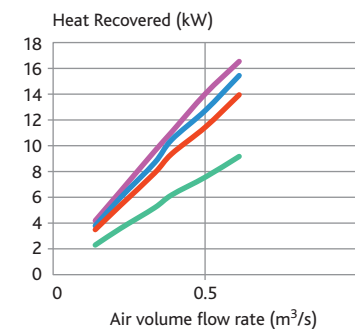
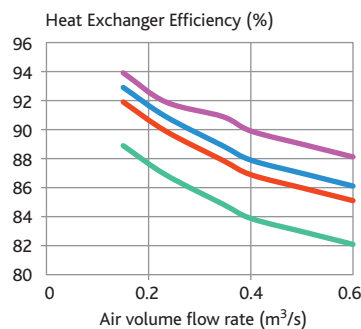

### HEATING COIL DATA LPHW

LPHW Deg C	Airflow (m³/s)	Output (kW)	Air Off Temp (C*)	Water flow (l/s)	Coil ΔP (kPa)	Pipe Connection (mm)	Valve ΔP (kPa)	Valve Type
LPHW 82/71	0.5	12.0	30	0.27	8.6	15	9	4 Port
	0.375	11.3	35	0.25	7.6	15	8.0	
	0.25	8.9	40	0.20	4.7	15	4.9	
LPHW 80/60	0.5	9.7	26	0.12	1.7	15	1.7	4 Port
	0.375	8.7	29	0.11	1.5	15	1.5	
	0.25	6.9	33	0.09	0.9	15	0.9	
LPHW 60/40	0.5	5.6	19	0.07	0.6	15	0.6	4 Port
	0.375	5.2	21	0.06	0.5	15	0.5	
	0.25	4.0	23	0.05	0.3	15	0.3	

\*Nb Limited to 30 Deg C for Ecosmart Units. Data based on 10 Deg C Air On temperature.

# XBC65 HORIZONTAL HEAT EXCHANGE UNITS

## PERFORMANCE & TECHNICAL INFORMATION

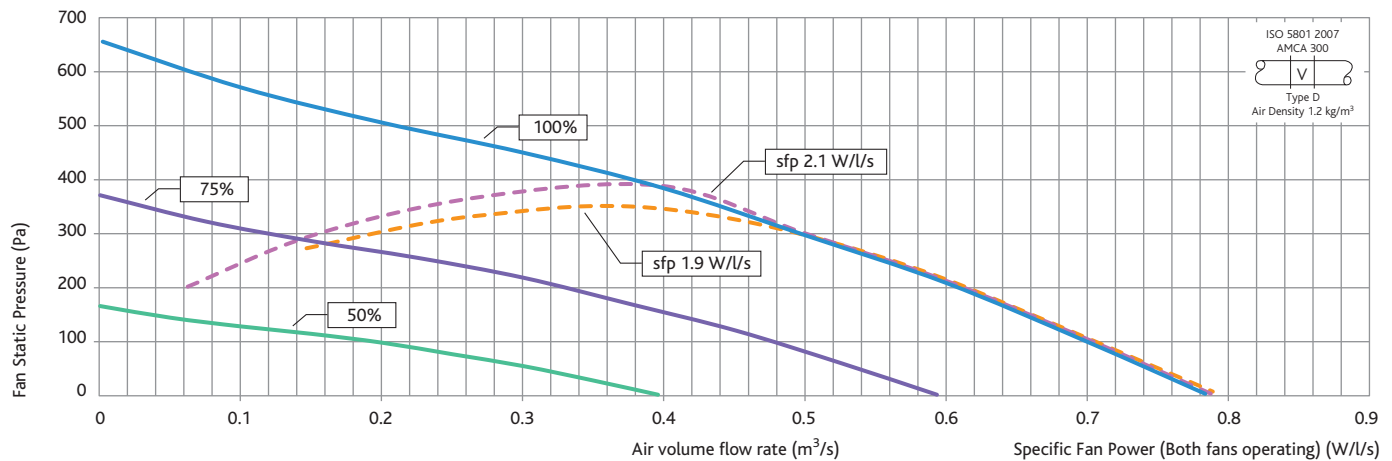

### XBC65 UNIT PERFORMANCE - EXAMPLE 0.55m³/s @ 150Pa = SFP 1.2, 32dBA @ 3m

Fan Speed	External Static Pressure (Pa)	Fan Speed								Fan Speed	External Static Pressure (Pa)									
		0	50	100	200	300	400	500	600			700	0	50	100	200	300	400	500	600
100%	Airflow (m³/s)	0.78	0.75	0.71	0.62	0.50	0.37	0.22	0.08	50%	Airflow (m³/s)	0.39	0.31	0.18						
	sfp (W/l/s)	1.20	1.28	1.34	1.52	1.78	2.20	3.40	3.95		sfp (W/l/s)	0.30	0.38	0.55						
	dBA@3m	35									dBA@3m	20								
75%	Airflow (m³/s)	0.59	0.54	0.48	0.32	0.13					25%	Airflow (m³/s)	0.20							
	sfp (W/l/s)	0.68	0.75	0.83	1.10	2.50						sfp (W/l/s)	0.10							
	dBA@3m	29								dBA@3m		< 20								

Specific Fan Power figures are the total for both fans operating.

For accurate figures, please refer to Nuair Fan Selection Programme at [www.nuair.co.uk](http://www.nuair.co.uk)

Unit Code	Voltage / Phase / Frequency	Input Power (W)	FLC / SC (A)	Max Operating Temperature	Fan Speed (rpm)	Unit Weight (kg)	Packed Weight (kg)	Pallet / crate dimensions (mm)
XBC65-H-L**	230 / 1 / 50	1540	8 / 8	40°C	1700	469	619	2150L x 1800W x 800H
XBC65-H-E**	230 / 1 / 50	10540*	47 / 47	40°C	1700	476	626	2150L x 1800W x 800H
XBC65-H-N**	230 / 1 / 50	1540	8 / 8	40°C	1700	465	615	2150L x 1800W x 800H

\*\*Add relevant code ie: BC, ES, CO or AT for control type. \*Includes 9kW Electric Heater.

### FAN UNIT DIMENSIONS (mm)

Note: All models (BC, ES, CO or AT) have a fold down (90°) pivoting control box for easy commissioning.

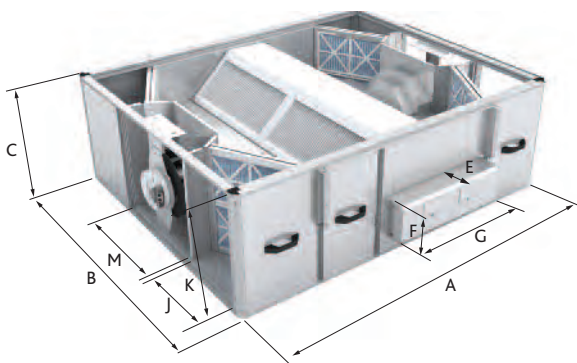

### XBC65 FAN CONFIGURATION

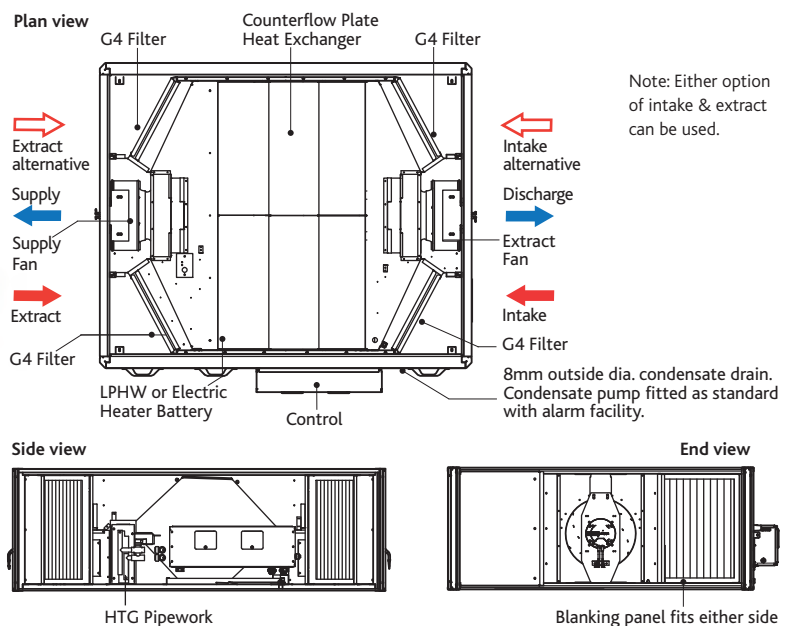

Fan Unit Dimensions (mm)			Control for all Models Dimensions (mm)			Rectangular Aperture Dimensions (mm)			Weather Roof for all Models Code XBC10-H-WP			Service & Maintenance Requirements	
A	B	C	E	F	G	J	K	M	H	x	W		x
1900	1560	620	120	200	670	402	578	592	95	1560	1900	The unit is designed for side access as standard and must be installed with a minimum of 260mm clearance from a wall or barrier. This will provide access to filters, coil, fan, heat exchanger, condensate tray and pump.	

2 attenuator flanges are attached to every unit. Add 50mm to dimension 'A' to include both flanges. Weather roof is separate code and can be retro fitted on site.

# XBC65 HORIZONTAL HEAT EXCHANGE UNITS

## PERFORMANCE & TECHNICAL INFORMATION

### XBC65 FAN - SOUND DATA

Fan Speed	Sound Power Levels (dB re 1 pW)	Frequency (Hz)								Spherical dBA@3m	Fan Speed	External Static Pressure (Pa)								Spherical dBA@3m
		63	125	250	500	1000	2000	4000	8000			63	125	250	500	1000	2000	4000	8000	
100%	Induct Intake	79	79	72	66	64	59	48	34	35	50%	64	64	57	51	49	44	33	< 20	20
	Induct Supply	83	85	79	74	72	68	61	54			68	70	64	59	57	53	46	39	
	Induct Discharge	85	85	79	75	72	69	61	55			70	70	64	60	57	54	46	40	
	Induct Extract	81	79	70	67	64	60	48	35			66	64	55	52	49	45	33	20	
	Casing Radiated	71	69	56	51	45	41	35	20			56	54	41	36	30	26	20	< 20	
75%	Induct Intake	73	73	66	60	58	53	42	28	29	25%	49	49	42	36	34	29	< 20	< 20	< 20
	Induct Supply	77	79	73	68	66	62	55	48			53	55	49	44	42	38	31	24	
	Induct Discharge	79	79	73	69	66	63	55	49			55	55	49	45	42	39	31	25	
	Induct Extract	75	73	64	61	58	54	42	29			51	49	40	37	34	30	18	5	
	Casing Radiated	65	63	50	45	39	35	29	< 20			41	39	26	21	< 20	< 20	< 20	< 20	

\*Casing Radiated (Breakout).

### ATTENUATOR DIMENSIONS (mm), DYNAMIC INSERTION LOSS (dB) & WEIGHTS (kg)

Attenuator Code	Attenuator Dimensions				Air path	Dynamic Insertion Loss (dB)								Attenuator Weight (kg)	Packed Weight (kg)
	Length	Width	Height	63		125	250	500	1000	2000	4000	8000			
XBC65-HS-MS10	1050	592	578	S / D	4	11	14	23	23	22	14	9	63	68	
XBC65-HE-MS10	1050	402	578	I / E	3	8	12	15	10	6	3	2	55	58	
XBC65-HS-MS12	1250	592	578	S / D	6	13	18	30	31	28	17	11	77	82	
XBC65-HE-MS12	1250	402	578	I / E	5	10	16	22	18	12	6	4	67	70	
XBC65-HS-MS16	1600	592	578	S / D	8	15	22	37	37	34	20	13	96	101	
XBC65-HE-MS16	1600	402	578	I / E	7	12	20	29	24	18	9	6	84	87	

S / D = Supply / Discharge I / E = Intake / Extract. Coding: The S / D denotes the type of silencer required for the supply or discharge. The I / E denotes the type of silencer required for the extract or fresh air intake on the unit. All XBC matched silencers are double skinned.

### COUNTERFLOW HEAT EXCHANGER EFFICIENCY (%)

Performance based on:  
Indoor Conditions 21 Deg C / 50 % RH

#### Key to performance curves

- Intake Temperature (Deg C)
- 5 Deg C Intake Typically Specified Values
- 3 Deg C Intake Typically Specified Values
- 1 Deg C Intake Typically Specified Values
- 6 Deg C Approx. Average outdoor temperature (UK heating season)

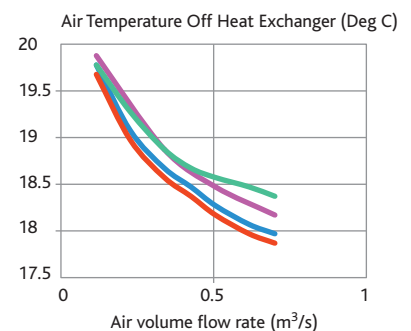
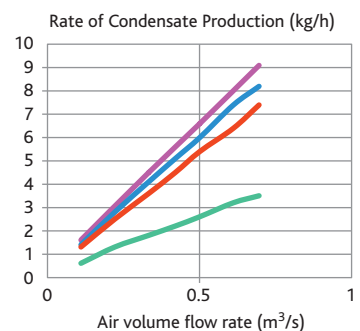
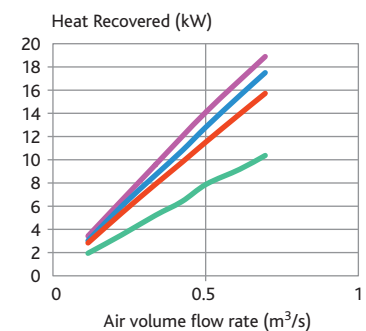
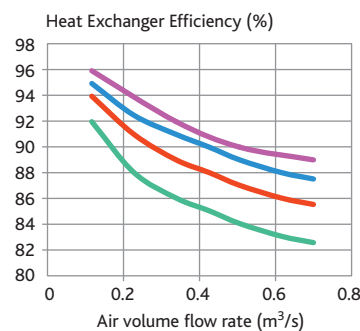

### HEATING COIL DATA LPHW

LPHW Deg C	Airflow (m³/s)	Output (kW)	Air Off Temp (C*)	Water flow (l/s)	Coil ΔP (kPa)	Pipe Connection (mm)	Valve ΔP (kPa)	Valve Type
LPHW 82/71	0.6	14.4	30	0.32	15.0	22	15	4 Port
	0.45	13.5	35	0.30	13.3	22	13.3	
	0.3	10.7	40	0.24	8.2	22	8.2	
LPHW 80/60	0.6	11.6	26	0.15	3.0	22	3	4 Port
	0.45	10.4	29	0.13	2.7	22	2.7	
	0.3	8.2	33	0.10	1.6	22	1.6	
LPHW 60/40	0.6	6.7	19	0.08	1.0	22	1	4 Port
	0.45	6.2	21	0.07	0.8	22	0.8	
	0.3	4.8	23	0.06	0.5	22	0.5	

\*Nb Limited to 30 Deg C for Ecosmart Units. Data based on 10 Deg C Air On temperature.

# XBOXER XBC10-65 HORIZONTAL UNITS

## ANCILLARIES

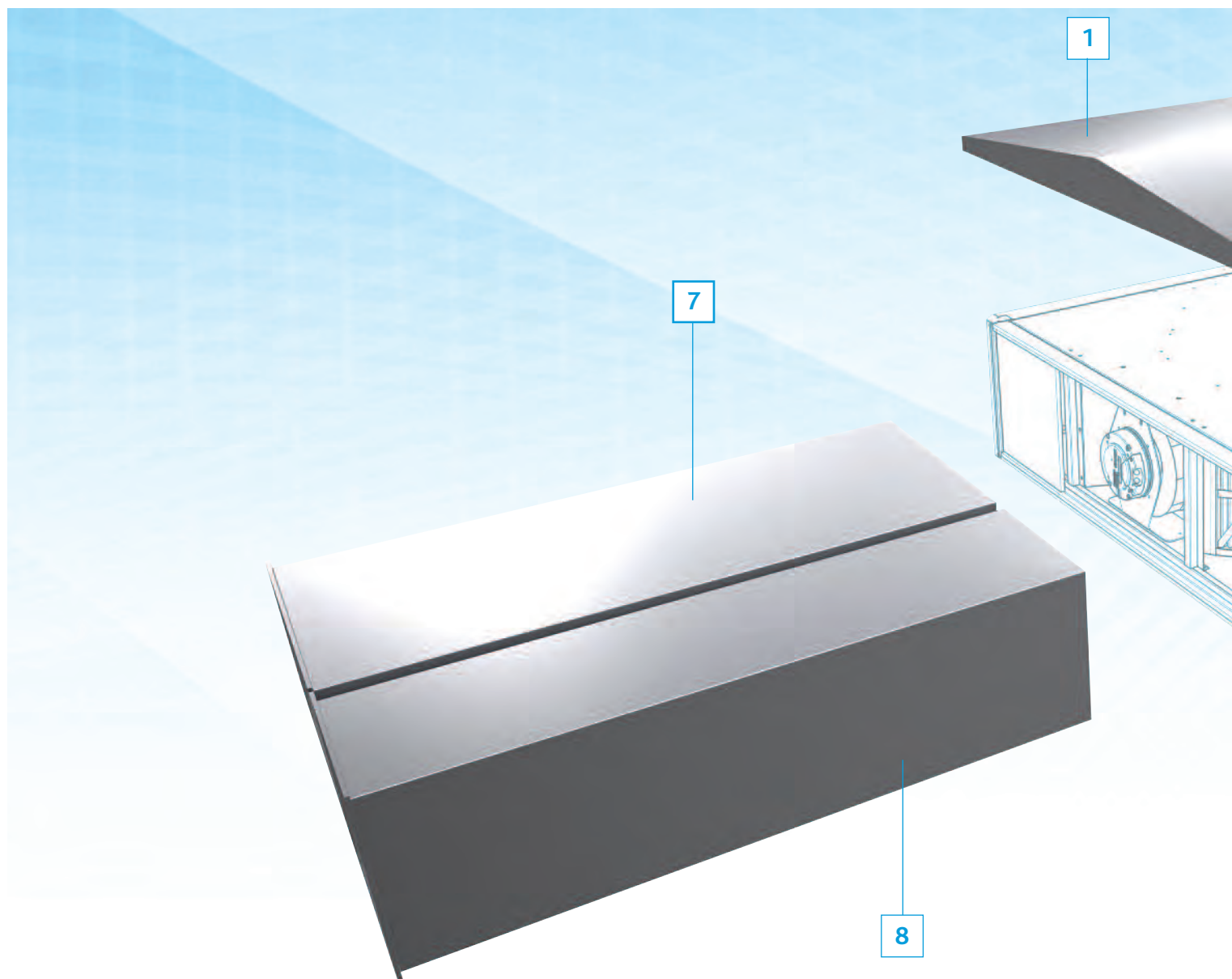

### QUICK SELECTION GUIDE XBC10 - 65 HORIZONTAL UNITS - ANCILLARIES

XBC Unit Size	Format	1	2	3	4		
		Weather Kit (All models)	Exhaust Roof Terminal	Intake Roof Terminal	Replacement Filter Options G3	G4	F7
XBC10	Horizontal	XBC15-H-WP	XBC15-EXHAUST-RT	XBC15-INTAKE-RT	XBC10-G3	n/a	n/a
XBC15	Horizontal	XBC15-H-WP	XBC15-EXHAUST-RT	XBC15-INTAKE-RT	n/a	XBC15-G4	XBC15-F7
XBC25	Horizontal	XBC25-H-WP	XBC25-EXHAUST-RT	XBC25-INTAKE-RT	n/a	XBC25-G4	XBC25-F7
XBC45	Horizontal	XBC45-H-WP	XBC45-EXHAUST-RT	XBC45-INTAKE-RT	n/a	XBC45-G4	XBC45-F7
XBC55	Horizontal	XBC55-H-WP	XBC55-EXHAUST-RT	XBC55-INTAKE-RT	n/a	XBC55-G4	XBC55-F7
XBC65	Horizontal	XBC65-H-WP	XBC65-EXHAUST-RT	XBC65-INTAKE-RT	n/a	XBC65-G4	XBC65-F7

XBC Unit Size	Format	5		6	
		Motorised Dampers (internal)**		Motorised Dampers (external)**	
		ES & BC models	AT models	ES & BC models	AT models
XBC10	Horizontal	XBC10-MD	XBC10-MD-AT	XBC10-MD-WP	XBC10-MD-AT-WP
XBC15	Horizontal	XBC15-MD	XBC15-MD-AT	XBC15-MD-WP	XBC15-MD-AT-WP
XBC25	Horizontal	XBC25-MD	XBC25-MD-AT	XBC25-MD-WP	XBC25-MD-AT-WP
XBC45	Horizontal	XBC45-MD	XBC45-MD-AT	XBC45-MD-WP	XBC45-MD-AT-WP
XBC55	Horizontal	XBC55-MD	XBC55-MD-AT	XBC55-MD-WP	XBC55-MD-AT-WP
XBC65	Horizontal	XBC65-MD	XBC65-MD-AT	XBC65-MD-WP	XBC65-MD-AT-WP

# XBOXER XBC 10-65 HORIZONTAL UNITS ANCILLARIES

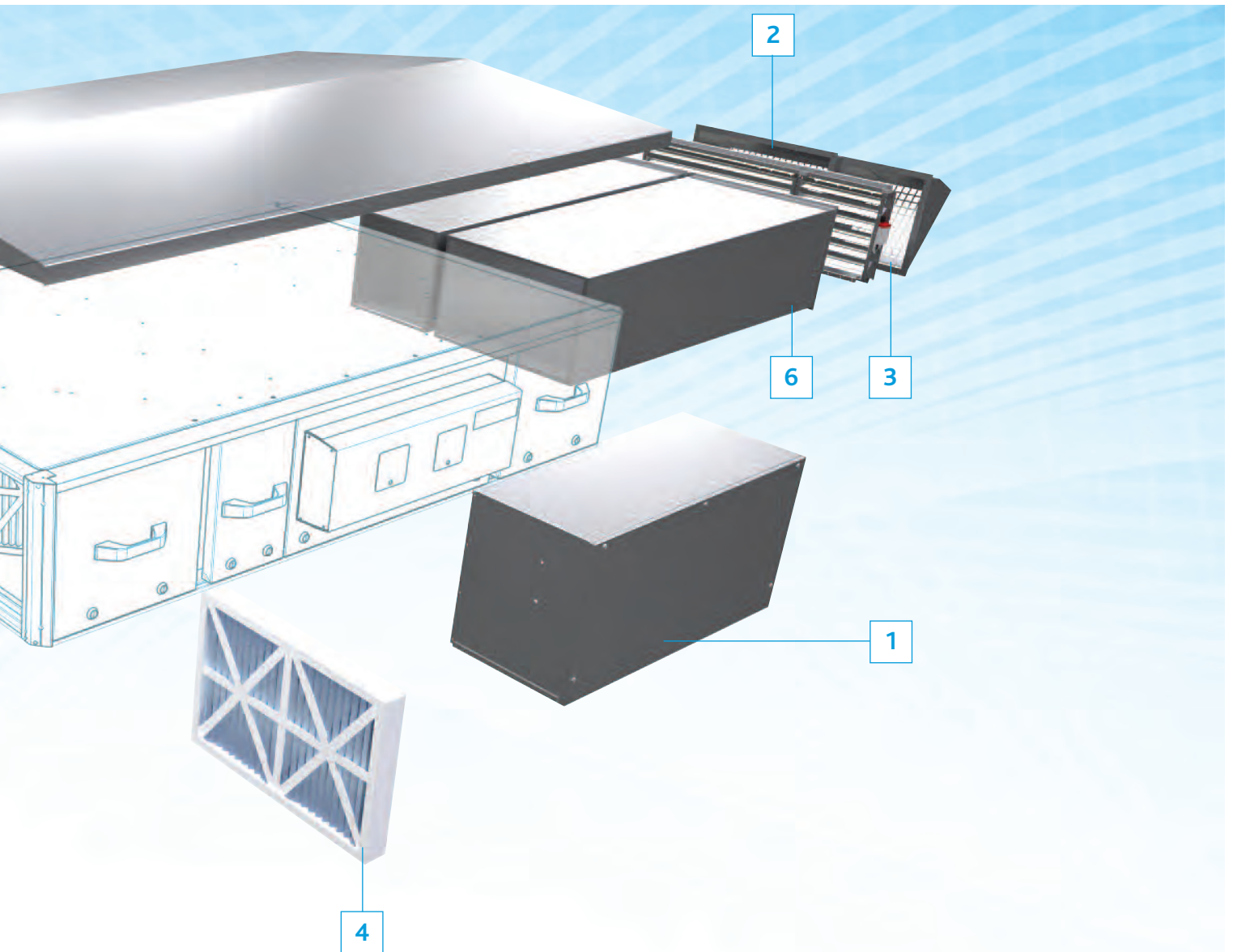

Refer to page 30-31 for bend silencer details. For details on Constant Pressure refer to pages 50-53.

## QUICK SELECTION GUIDE XBC10 - 65 HORIZONTAL UNITS - MATCHING STRAIGHT ATTENUATORS

XBC Unit Size	Format	7			8		
		Matching Silencers S/D (Supply)			Matching Silencers I/E (Extract)		
		1050mm long	1250mm long	1600mm long	1050mm long	1250mm long	1600mm long
XBC10	Horizontal	XBC15-HS-MS10	XBC15-HS-MS12	XBC15-HS-MS16	XBC15-HE-MS10	XBC15-HE-MS12	XBC15-HE-MS16
XBC15	Horizontal	XBC15-HS-MS10	XBC15-HS-MS12	XBC15-HS-MS16	XBC15-HE-MS10	XBC15-HE-MS12	XBC15-HE-MS16
XBC25	Horizontal	XBC25-HS-MS10	XBC25-HS-MS12	XBC25-HS-MS16	XBC25-HE-MS10	XBC25-HE-MS12	XBC25-HE-MS16
XBC45	Horizontal	XBC45-HS-MS10	XBC45-HS-MS12	XBC45-HS-MS16	XBC45-HE-MS10	XBC45-HE-MS12	XBC45-HE-MS16
XBC55	Horizontal	XBC55-HS-MS10	XBC55-HS-MS12	XBC55-HS-MS16	XBC55-HE-MS10	XBC55-HE-MS12	XBC55-HE-MS16
XBC65	Horizontal	XBC65-HS-MS10	XBC65-HS-MS12	XBC65-HS-MS16	XBC65-HE-MS10	XBC65-HE-MS12	XBC65-HE-MS16

Matching flange is supplied attached to all XBC units.

### ACOUSTIC STRAIGHT ATTENUATOR COMBINATION EXAMPLES

Matched silencers can be flipped to suit left/right side. (1050/1250/1600mm lengths).  
\*Contact Nuairé for details of these variants.



# XBOXER XBC10-65 HORIZONTAL UNITS

## ANCILLARIES - NEW BEND SILENCERS



Supply/Discharge Bend Attenuator

### WHERE TO USE BEND ATTENUATORS

The New bend matched silencers are ideal for projects where space is limited and the straight matched silencers cannot be fitted.

The bend silencers are fitted with the matching flange at either end allow for additional straight silencers to also be added if required.

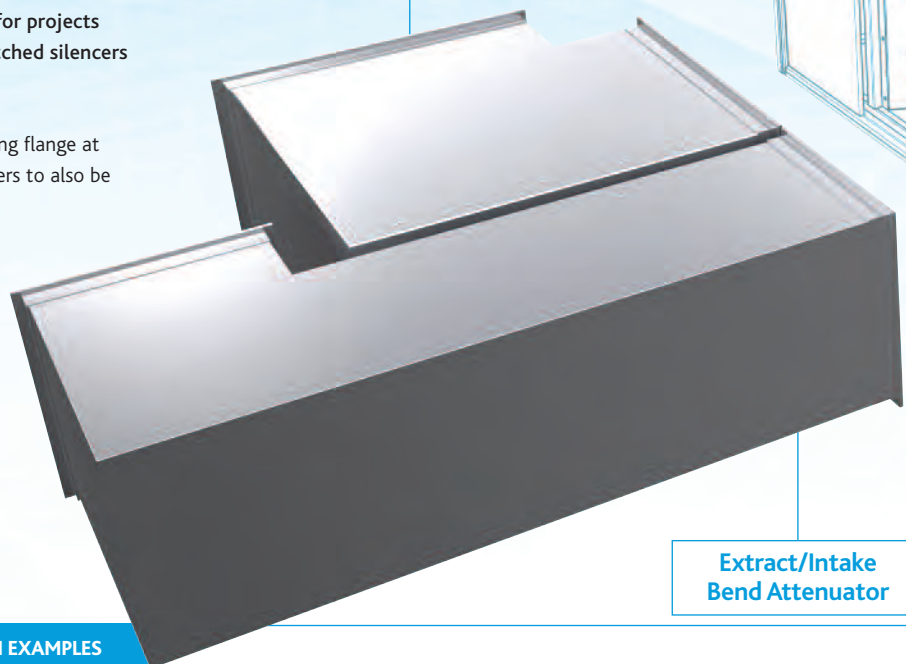

Extract/Intake Bend Attenuator

### ACOUSTIC BEND ATTENUATOR COMBINATION EXAMPLES

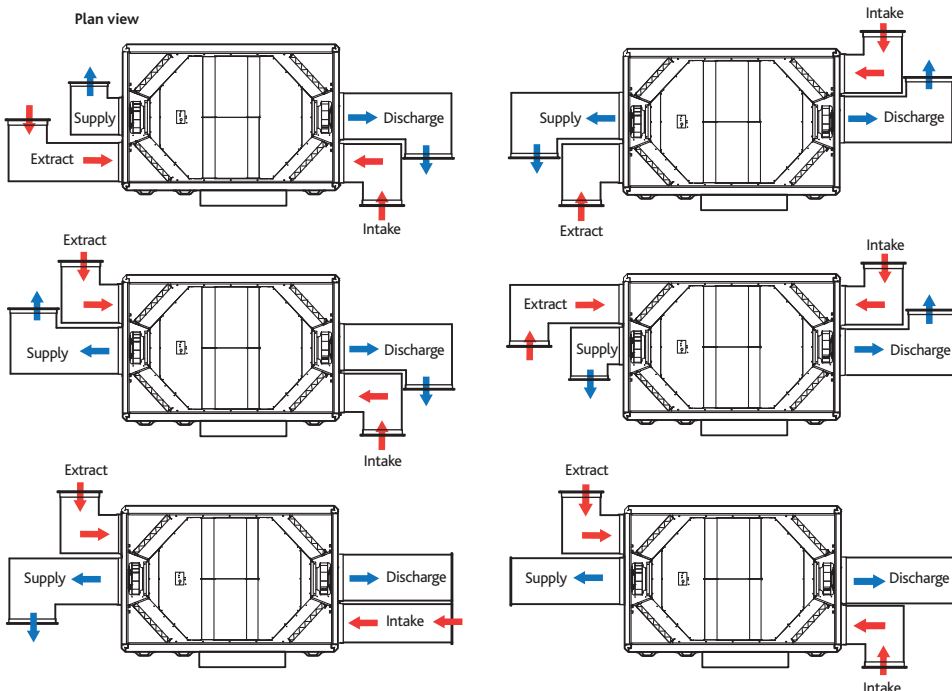

### BEND SILENCER CODE DESCRIPTION

XBC15-HE-MBS-S

1 2 3 4 5

1. XBOXER XBC Range
2. Unit size: 15, 25, 45, 55 or 65
3. HE = Horizontal Extract/Intake  
HS = Horizontal Supply/Discharge
4. Matched Bend Silencer
5. S = Short (refer to dimensions)  
L = Long (refer to dimensions)

## XBOXER XBC10-65 HORIZONTAL UNITS ANCILLARIES - NEW BEND SILENCERS

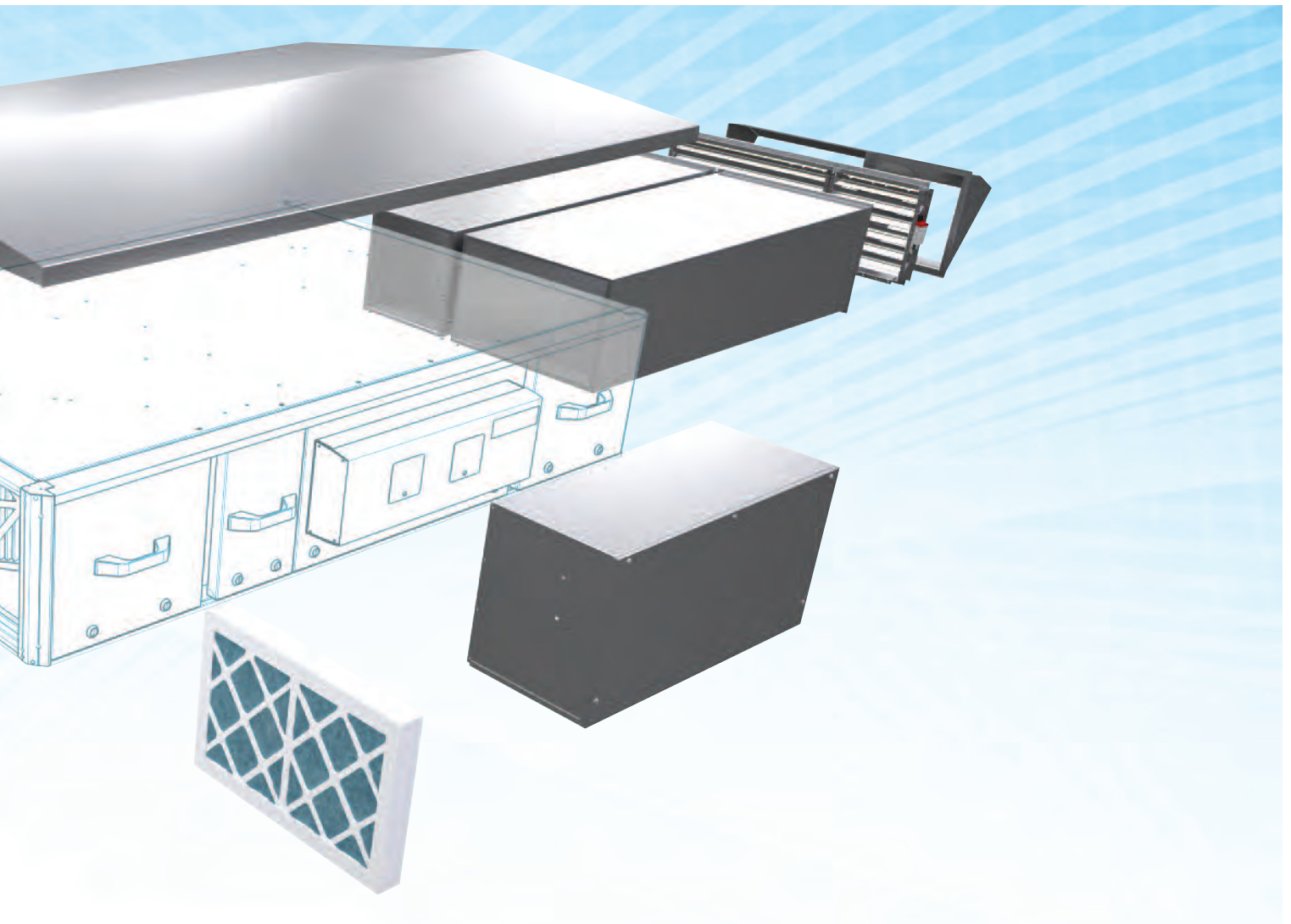

**XBC10 - 65 HORIZONTAL UNITS BEND ATTENUATOR DIMENSIONS (mm), DYNAMIC INSERTION LOSS (dB) & WEIGHTS (kg)**

XBC Unit size	Attenuator Code	Attenuator Description	Attenuator Dimensions			Dynamic Insertion Loss (dB)								Attenuator Weight (kg)	"Z" Factor
			Length	Width	Height	63	125	250	500	1000	2000	4000	8000		
XBC10	XBC15-HS-MBS-S	Supply or discharge side	496	340	225	2	4	9	17	30	33	25	19	36	900.0
XBC10	XBC15-HS-MBS-L	Supply or discharge side	833	340	225	2	5	12	22	38	39	28	22	46	1100.0
XBC10	XBC15-HE-MBS-S	Extract or intake side	387	250	225	2	4	10	18	32	35	25	20	36	2000.0
XBC10	XBC15-HE-MBS-L	Extract or intake side	833	250	225	3	5	13	24	42	41	29	23	44	2300.0
XBC15	XBC15-HS-MBS-S	Supply or discharge side	496	340	225	2	4	9	17	30	33	25	19	36	2300.0
XBC15	XBC15-HS-MBS-L	Supply or discharge side	833	340	225	2	5	12	22	38	39	28	22	46	2300.0
XBC15	XBC15-HE-MBS-S	Extract or intake side	387	250	225	2	4	10	18	32	35	25	20	36	2300.0
XBC15	XBC15-HE-MBS-L	Extract or intake side	833	250	225	3	5	13	24	42	41	29	23	44	2300.0
XBC25	XBC25-HS-MBS-S	Supply or discharge side	621	455	305	2	4	8	16	29	22	14	10	50	156.3
XBC25	XBC25-HS-MBS-L	Supply or discharge side	937	455	305	2	5	10	21	38	25	17	13	64	173.6
XBC25	XBC25-HE-MBS-S	Extract or intake side	402	265	305	2	4	8	16	29	22	14	10	40	208.3
XBC25	XBC25-HE-MBS-L	Extract or intake side	937	265	305	2	5	10	38	25	17	13	50	54	225.7
XBC45	XBC45-HS-MBS-S	Supply or discharge side	681	525	365	3	6	9	17	29	21	13	7	60	116.9
XBC45	XBC45-HS-MBS-L	Supply or discharge side	1051	525	365	4	7	10	21	37	26	15	8	72	131.5
XBC45	XBC45-HE-MBS-S	Extract or intake side	420	280	365	3	6	9	17	29	21	13	7	42	146.1
XBC45	XBC45-HE-MBS-L	Extract or intake side	1051	280	365	4	7	10	21	37	26	15	8	58	160.7
XBC55	XBC55-HS-MBS-S	Supply or discharge side	737	580	435	3	7	10	21	37	26	15	8	68	80.0
XBC55	XBC55-HS-MBS-L	Supply or discharge side	1234	580	435	4	10	18	31	39	24	12	7	96	92.0
XBC55	XBC55-HE-MBS-S	Extract or intake side	547	410	435	3	6	10	18	24	16	9	6	48	80.0
XBC55	XBC55-HE-MBS-L	Extract or intake side	1234	410	435	4	10	18	31	39	24	12	7	72	100.0
XBC65	XBC65-HS-MBS-S	Supply or discharge side	737	580	585	3	8	14	23	22	14	7	4	76	44.4
XBC65	XBC65-HS-MBS-L	Supply or discharge side	1234	580	585	4	10	19	31	30	18	9	5	106	50.0
XBC65	XBC65-HE-MBS-S	Extract or intake side	547	410	585	3	8	14	23	22	14	7	4	54	55.6
XBC65	XBC65-HE-MBS-L	Extract or intake side	1234	410	585	4	10	19	31	30	18	9	5	86	63.9

Matching flange is supplied attached to all XBC units.

Note: Air Pressure Drop of Attenuator (Pa) =  $Z \cdot Q^2$  where Z = Factor listed in table above Pa/Q<sup>2</sup>.

# XBC10-65 HORIZONTAL HEAT EXCHANGE UNITS

## CONSULTANTS SPECIFICATION

### OPERATION

The supply and extract ventilation unit shall be configured as indicated on the drawings. The heat recovery ventilation unit shall enable the room design conditions to be maintained by the effective and continuous control of ventilation rate, the integrated counterflow heat exchanger matrix and bypass, and heating facility.

The ventilation unit shall automatically vary the ventilation rate in the space dependent upon the signals received from the interconnected sensors and user interface (where provided). When signals are received, the unit shall vary its fan speeds proportionally until the desired set points are met.

The unit shall have the facility to commission the supply and extract fans individually via inbuilt maximum, minimum and offset speed adjustments. Each fan shall have stepless variable speed control (20 – 100% of maximum). The unit shall be the XBC10-65\*\* as manufactured by Nuaira.

### UNIT SPECIFICATION

The heat recovery ventilation unit together with matching silencers shall have a maximum depth of 260 / 340 / 400 / 470 / 620mm (Models XBC10 to 65\*\*).

The ventilation unit and attenuators shall have an asymmetric, high mass double skinned wall construction (patent applied for) with integral acoustic barrier mat\* ensuring low breakout noise levels. The unit and attenuators shall be supplied complete with suspension brackets for inclusion into a drop rod mounting system.

The unit shall incorporate a high efficiency aluminium counterflow plate heat exchanger matrix with a thermal efficiency of up to 96%, fitted with a segmented 100% bypass facility and patented actuator operating under automatic control. The automatic operation of the XBC bypass is determined by an algorithm that varies output based on temperatures, and whether the control system has been set to prioritise heating, ventilation or cooling. All elements of the unit shall be protected from airborne contamination by high capacity pleated G4 panel filters (supply and extract). Two spare filters are provided for post-construction phase fitting.

The unit shall be fitted with ErP 2016 rated, low energy, high efficiency IP54 EC motorised fans providing low specific fan powers and stepless speed control, without tonal noise generation. Fan/motor assemblies have sealed for life bearings with an anticipated working life of 70,000 hours (L10) and shall be suitable for single phase supply.

Impellers shall be of high efficiency, performance and sound optimised backward curved design.

The unit shall be fitted with either an Electric heater battery (code example XBC15-H-EES) with burst fired temperature controller; or a LPHW heater battery (code example XBC15-H-LES), complete with factory fitted valve and actuator, terminating at the unit casing.

The system shall have frost protection (Ecosmart models only) which shall, at temperatures below 4 degrees C, fully open the 4-port valve and only start the fan when the temperature within the chamber has risen above the designated set point.

The LPHW assembly shall be pressure tested at works to a minimum of 6 Bar.

The control for the heaters shall be fully integrated and shall maintain a constant temperature\*\*\* to meet the system design requirements.

\*\*\*The heating output (LPHW or electric) is automatically regulated to control the Air - Off condition.

The unit is also available without a heater fitted (code example XBC15-H-NBC).

\*Note: XBC10 contains specialist acoustic treatment and has G3 panel filter (supply and extract).

The unit shall be constructed with removable side panels allowing maintenance access with minimal service space clearance required.

The removable panels shall provide access to the following:-

- Supply and extract fan.
- Supply and extract filter.
- Condensate tray.
- All control adjustments (where included).

Bottom access variants are available (for filter only).

### UNIT CONFIGURATION

Supply/discharge airflow connections are on the unit centreline; Intake/Extract connections are configurable on site to either side of the unit. Unit is supplied as configuration A as standard (refer to technical documentation).

The ventilation unit shall comprise the following:-

Supply and extract fans, high efficiency counterflow plate heat exchanger matrix, supply and extract filters, full 100% automatic heat exchanger bypass, heating coil (as selected) & condensate drip tray, a condensate pump is installed in the unit and has an alarm function (connection by others). If the water level in the condensate tray exceeds a maximum level (for example, as a result of the discharge tube becoming blocked or frozen), the alarm contact will open. This contact is internally connected to the heat exchanger bypass actuator, and the unit will automatically be placed into bypass mode, preventing further condensate production. Unit operation will otherwise be unaffected.

Matching high mass double skinned wall construction attenuators can also be provided by Nuaira.

### CODE DESCRIPTION

XBC15-H-LES-R-BA  
| | | | | | | |  
1 2 3 4 5 6 7 8

1. XBOXER
2. Counterflow heat exchanger
3. Unit size
4. H = Horizontal
5. Type of heater battery:  
L = LPHW, E = Electric, N = No heater
6. Control type:  
AT = Ecosmart Adapt (Trend)  
CO = Ecosmart Connect  
ES = Ecosmart Classic  
BC = Basic control
7. R = Opposite configuration
8. BA = Bottom access for filter removal (XBC10-45 units only)

For further details on the ErP directive please refer to [www.nuaira.co.uk](http://www.nuaira.co.uk)



# XBC10-65 CONTROL OPTIONS

## CONSULTANTS SPECIFICATION

### BASIC CONTROL OPTION

Unit is provided with side access terminal boxes for direct supply and extract fan motor wiring and for interfacing to custom built control panels. The control assembly is side mounted with a 90° rotation facility for wiring and commissioning adjustments in restricted access conditions. (260mm access allowance is required).

A side mounted terminal box is provided for the connections to the fans (230V 50Hz LNE and 2-10V), and Electric heater terminal and thermal protection (where specified).

For this option, no sensors are fitted to the unit, but note that the plate heat exchanger bypass damper actuator is included suitable for 230V standard (24V available).

Units fitted with Basic Control (code example XBC25-H-EBC) have a 2 year warranty.

### ECOSMART CLASSIC OPTION - DEMAND CONTROLLED VENTILATION

Provides the facility for energy saving via an intelligent stand-alone AHU function with local diagnostic status indication, or allows convenient integration with the client BMS with a minimal co-ordination requirement.

The factory fitted Ecosmart Classic control includes:- integral infinitely variable speed / duty control for the supply and extract fans, with independent minimum, maximum and offset adjustment (up to 40%) for accurate commissioning. The control assembly is side mounted with a 90° rotation facility for wiring and commissioning adjustments in restricted access conditions. (260mm access allowance is required).

The control features a run on timer and "background" ventilation function, and is provided with unit status indication, run and fail relays and interface connections for Ecosmart Classic sensors/enablers and system dampers.

The heat exchanger bypass is automatically operated according to temperature and a pre-defined strategy.

\*\*\*The heating output (LPHW or electric) is automatically regulated to control the Air - Off condition.

The Ecosmart control module can additionally be connected to provide the following integrated BMS interfaces.

- 0 - 10 volt inputs. This will enable the following functions:- Switch the unit ON/OFF. Variable speed / duty control, Switch from low speed to high speed, Enable heating/cooling.
- 2 No. Volt free contacts give fan run and failure unit status indication.

Units fitted with Ecosmart Classic control (code example XBC15-H-LES) have a 5 year warranty.

### ECOSMART CONNECT OPTION – ENHANCED DEMAND CONTROLLED VENTILATION

A comprehensive unit control specification - factory fitted and tested to provide guaranteed operation from a single supplier – one who will take responsibility.

The unit integrated Ecosmart Connect system provides the facility for operational efficiency and energy saving by allowing a comprehensive range of unitary control functions and / or full BMS integration (by others) via standard BACnet (MS/TP).

The system incorporates a web access enabled controller, and is augmented by application specific unit interface and diagnostic circuits. Controller software is optimised and pre-configured, and each unit / control assembly is fully functionally tested at works (Refer to technical documentation for full controller functional specification).

Units fitted with Ecosmart Connect control (code example XBC45-H-CO) have a 5 year warranty. (Refer to 'Description of control' for further details).

### ECOSMART ADAPT WITH TREND OPTION – ENHANCED DEMAND CONTROLLED VENTILATION

A comprehensive unit control specification - factory fitted and tested to provide guaranteed operation from a single supplier – one who will take responsibility.

The unit integrated Ecosmart Adapt system provides the facility for operational efficiency and energy saving by allowing a comprehensive range of unitary control functions and / or full BMS integration (by others) via standard BACnet IP configuration.

The system incorporates a web access enabled Trend IQ422/12/LAN/BAC/230 controller, and is augmented by application specific unit interface and diagnostic circuits. Controller software is optimised and pre-configured, and each unit / control assembly is fully functionally tested at works (Refer to technical documentation for full controller functional specification).

Units fitted with Ecosmart Adapt control (code example XBC45-H-LAT) have a 5 year warranty. (Refer to 'Description of control' for further details).

The unit shall be the XBC10-65 as manufactured by Nuair.

# XBC10-65 HORIZONTAL HEAT EXCHANGE UNITS

## UNIT WIRING

### WIRING - FOR UNITS SUPPLIED WITHOUT ECOSMART CLASSIC CONTROL (EXAMPLE CODING XBC45-H-LBC)

The wiring illustrations below are for the fans, bypass damper and electric heater for units without control.

Note that any heating/cooling coils fitted are supplied without control valve and actuator.

Note: Do not wire the power supply to motor via motor thermal overload as these are only closed after the motor is energized.

Thermal overload contact rating is 2A max resistive.

Note: The Alarm relay on condensate may require the use of a contactor if the host equipment supply is to be switched.

#### ELECTRIC HEATER XBC25-65 ONLY

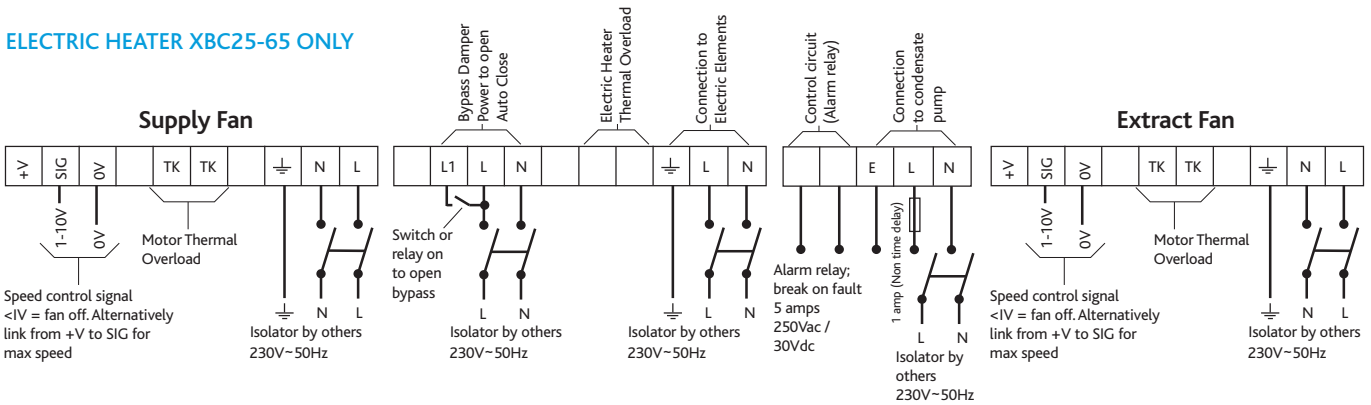

#### ELECTRIC HEATER XBC10-15 ONLY

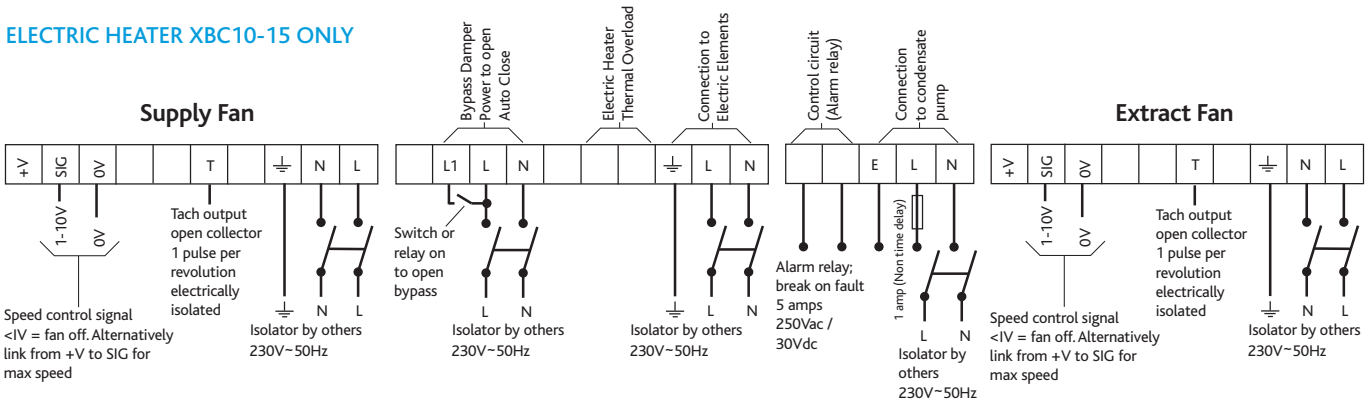

#### LPHW & NO HEATER XBC25-65 ONLY

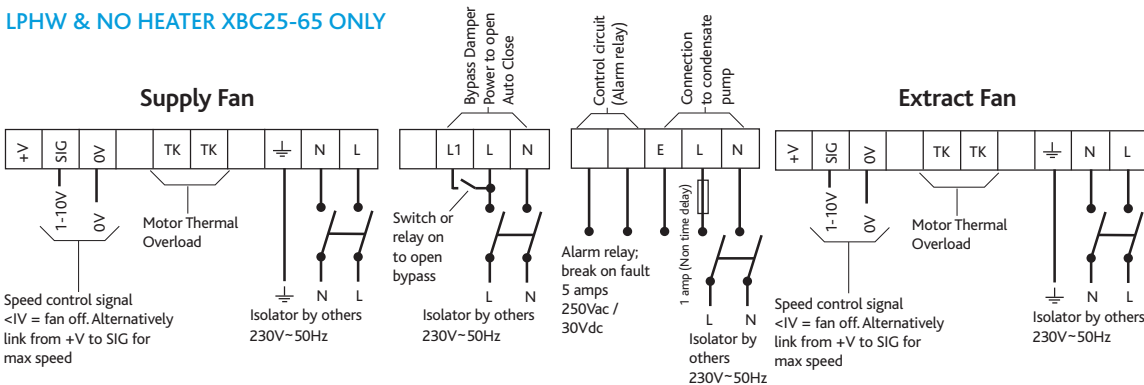

#### LPHW & NO HEATER XBC10-15 ONLY

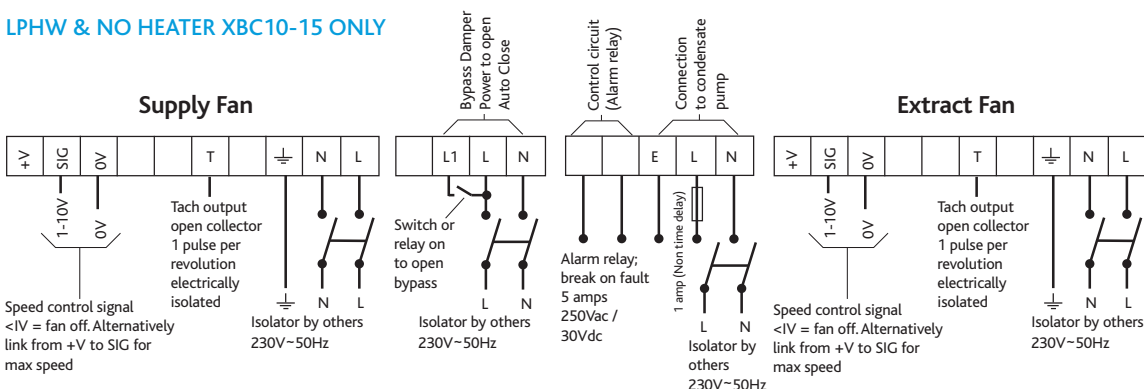

# XBC10-65 HORIZONTAL HEAT EXCHANGE UNITS UNIT WIRING

## UNITS WITH ECOSMART CLASSIC CONTROL & LPHW COIL CONTROL (CODING EXAMPLE XBC15-H-LES)

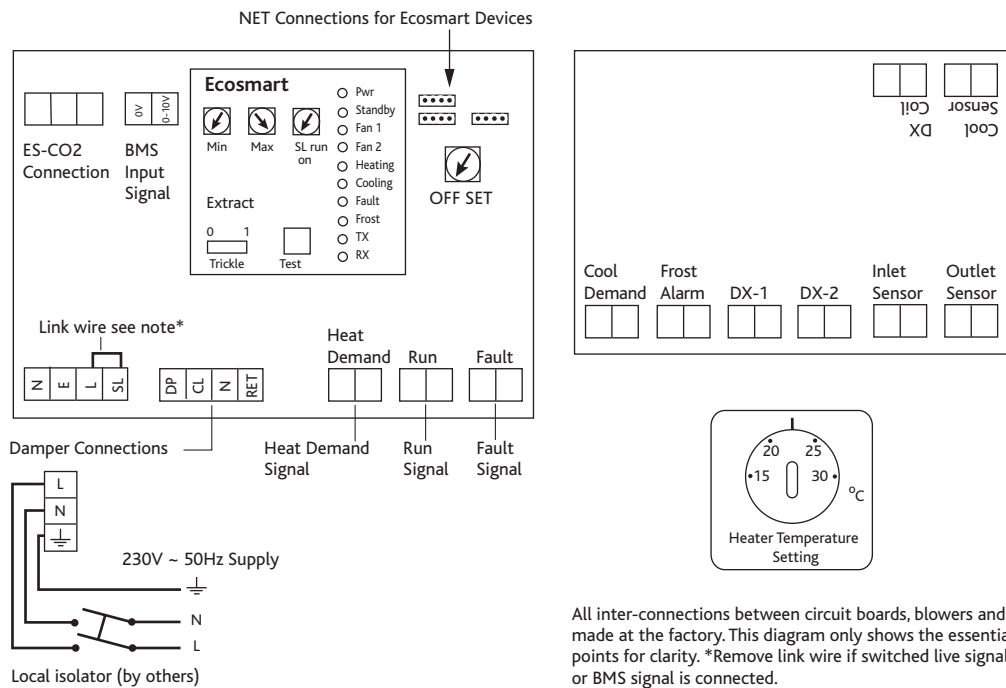

All inter-connections between circuit boards, blowers and sensors are made at the factory. This diagram only shows the essential field wiring points for clarity. \*Remove link wire if switched live signal, an enabler or BMS signal is connected.

## UNITS WITH ECOSMART CLASSIC CONTROL & ELECTRIC HEATER (CODING EXAMPLE XBC45-H-EES)

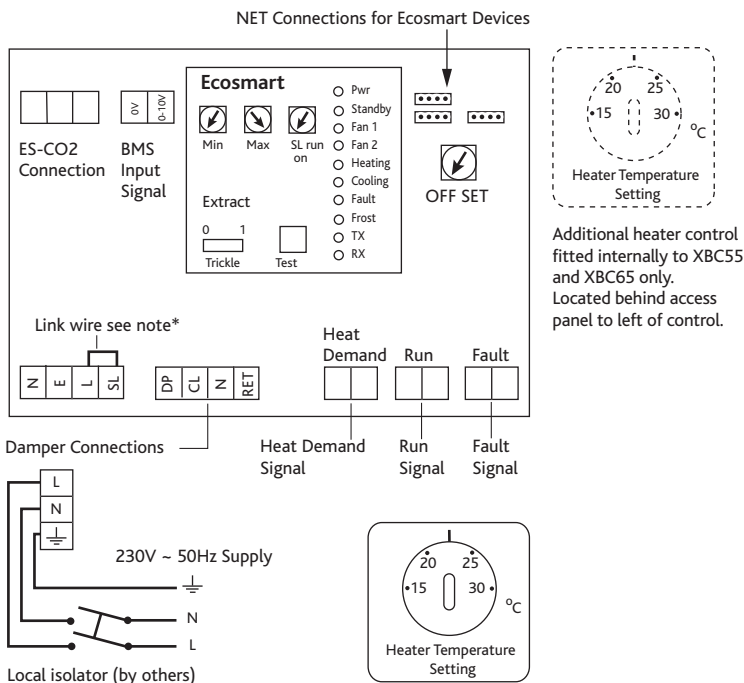

All inter-connections between circuit boards, blowers and sensors are made at the factory. This diagram only shows the essential field wiring points for clarity. \*Remove link wire if switched live signal, an enabler or BMS signal is connected.

## UNITS WITH ECOSMART CLASSIC FAN ONLY CONTROL (CODING EXAMPLE XBC25-H-NES)

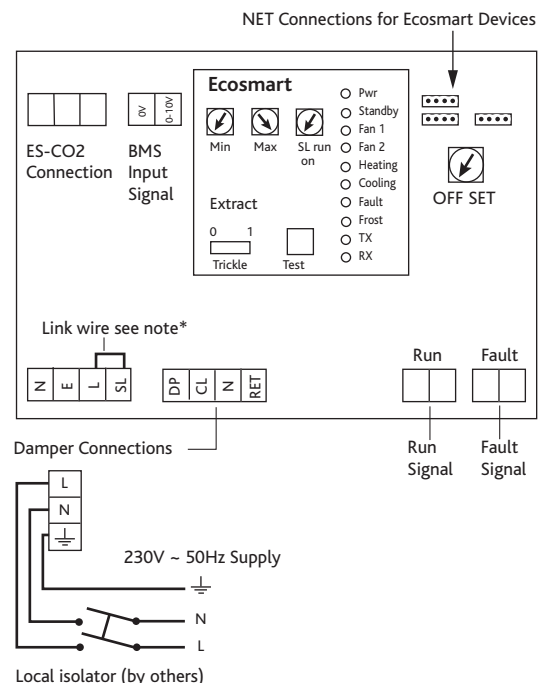

All inter-connections between circuit boards, blowers and sensors are made at the factory. This diagram only shows the essential field wiring points for clarity. \*Remove link wire if switched live signal, an enabler or BMS signal is connected.

**ECOSMART WIRING** For Ecosmart Connect and Adapt  
Trend wiring please contact Nuair.

# XBC75 HORIZONTAL HEAT EXCHANGE UNITS

## PERFORMANCE & TECHNICAL INFORMATION

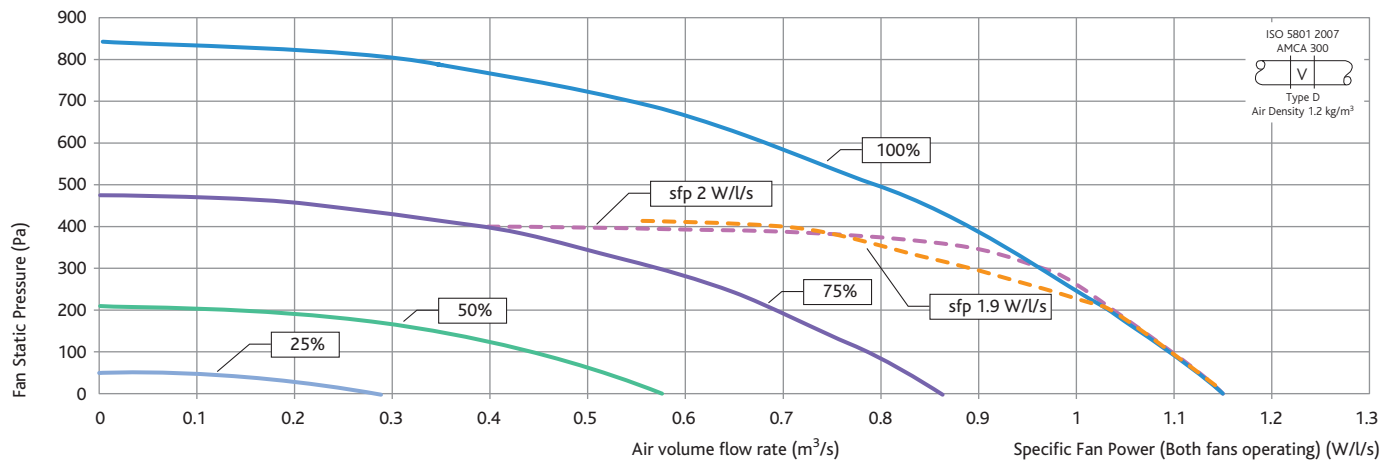

### XBC75 HORIZONTAL UNIT PERFORMANCE

Fan Speed	External Static Pressure (Pa)	Fan Speed								Fan Speed	External Static Pressure (Pa)												
		0	50	100	200	300	400	500	600			0	50	100	200	300	400	500	600				
100%	Airflow (m³/s)	1.15	1.13	1.10	1.04	0.97	0.89	0.80	0.68	50%	Airflow (m³/s)	0.58	0.52	0.45	0.15								
	sfp (W/l/s)	1.57	1.64	1.74	1.90	2.06	2.22	2.41	2.74		sfp (W/l/s)	0.38	0.47	0.55	1.36								
	dBA@3m	41									dBA@3m	26											
75%	Airflow (m³/s)	0.86	0.83	0.78	0.69	0.57	0.38					25%	Airflow (m³/s)	0.29									
	sfp (W/l/s)	0.89	0.97	1.07	1.21	1.41	2.01						sfp (W/l/s)	0.2 (approx)									
	dBA@3m	35								dBA@3m	<20												

Specific Fan Power figures are the total for both fans operating.

For accurate figures, please refer to Nuair Fan Selection Programme at [www.nuair.co.uk](http://www.nuair.co.uk)

Unit Code	Voltage / Phase / Frequency	Input Power (W)	FLC / SC (A)	Max Operating Temperature	Fan Speed (rpm)	Unit Weight (kg)	Packed Weight (kg)	Pallet / crate dimensions (mm)
XBC75-H-L**	400 / 3 / 50	2100	3.5 / 3.5	40°C	2140	720	902	3000L x 2600W x 1041H
XBC75-H-E**	400 / 3 / 50	14100*	21 / 21	40°C	2140	720	902	3000L x 2600W x 1041H
XBC75-H-N**	400 / 3 / 50	2100	3.5 / 3.5	40°C	2140	720	902	3000L x 2600W x 1041H

\*\*Add relevant code ie: BC, ES, CO or AT for control type.

\*Includes 12kW Electric Heater.

Add 'R' to relevant code for opposite configuration ie: XBC75-H-LES-R.

### FAN UNIT DIMENSIONS (mm)

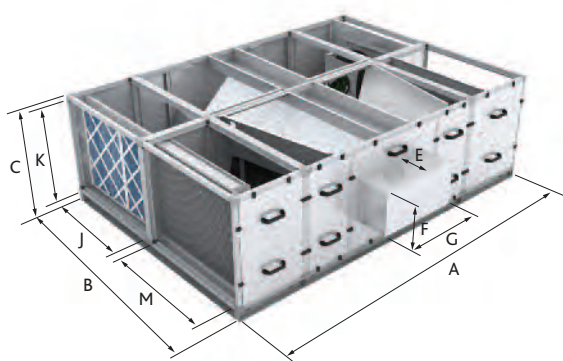

### XBC75 HORIZONTAL FAN CONFIGURATION

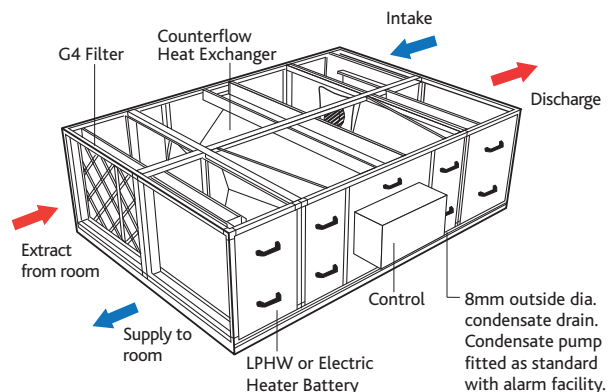

Fan Unit Dimensions (mm)			Control for all Models Dimensions (mm)			Rectangular Aperture Dimensions (mm)			Weather Roof for all Models Code XBC75-H-LESWP			Service & Maintenance Requirements	
A	B	C	E	F	G	J	K	M	H	x	W		x
2800	2126	876*	250	730	800	940	740	940	125	2126	2800		

The unit is designed for side access as standard and must be installed with a minimum of 650mm clearance from a wall or barrier. This will provide access to filters, coil, fan, heat exchanger, condensate tray and pump.

All models - the weather roof is part of the unit code and is factory fitted only. Example: XBC75-H-LESWP.

\*Includes unit and base rail.

# XBC75 HORIZONTAL HEAT EXCHANGE UNITS

## PERFORMANCE & TECHNICAL INFORMATION

### XBC75 HORIZONTAL FAN - SOUND DATA

Fan Speed	Sound Power Levels (dB re 1 pW)	Frequency (Hz)								Spherical dBA@3m	Fan Speed	External Static Pressure (Pa)								Spherical dBA@3m
		63	125	250	500	1000	2000	4000	8000			63	125	250	500	1000	2000	4000	8000	
100%	Induct Intake	81	80	79	82	75	69	63	59	41	50%	66	65	64	67	60	54	48	44	26
	Induct Supply	82	78	72	79	76	66	50	50			67	63	57	64	61	51	35	35	
	Induct Discharge	85	84	79	87	86	78	71	67			70	69	64	72	71	63	56	52	
	Induct Extract	79	73	71	73	68	63	59	58			64	58	56	58	53	48	44	43	
	Casing Radiated	75	67	64	62	53	45	46	38			60	52	49	47	38	30	31	23	
75%	Induct Intake	75	74	73	76	69	63	57	53	35	25%	54	53	52	55	48	42	36	32	<20
	Induct Supply	76	72	66	73	70	60	44	44			55	51	45	52	49	39	23	23	
	Induct Discharge	79	78	73	81	80	72	65	61			58	57	52	60	59	51	44	40	
	Induct Extract	73	67	65	67	62	57	53	52			52	46	44	46	41	36	32	31	
	Casing Radiated	69	61	58	56	47	39	40	32			48	40	37	35	26	<20	<20	<20	

\*Casing Radiated (Breakout).

### ATTENUATOR (SIDE BY SIDE) DIMENSIONS (mm), DYNAMIC INSERTION LOSS (dB) & WEIGHTS (kg)

Attenuator* Code	Attenuator Dimensions			Dynamic Insertion Loss (dB)								Attenuator Weight (kg)	Packed Weight (kg)
	Length	Width	Height**	63	125	250	500	1000	2000	4000	8000		
XBC75-H-SIL900	900	2000	876	0	6	8	18	22	20	16	15	180	190
XBC75-H-SIL900WP	900	2000	1001	0	6	8	18	22	20	16	15	185	195

\*Attenuator sections are side by side, one piece modules. \*\*Includes 76mm base frame.

### COUNTERFLOW HEAT EXCHANGER EFFICIENCY (%)

Performance based on:  
Indoor Conditions 21 Deg C / 50 % RH

#### Key to performance curves

- Intake Temperature (Deg C)
- 5 Deg C Intake Typically Specified Values
- 3 Deg C Intake Typically Specified Values
- 1 Deg C Intake Typically Specified Values
- 6 Deg C Approx. Average outdoor temperature (UK heating season)

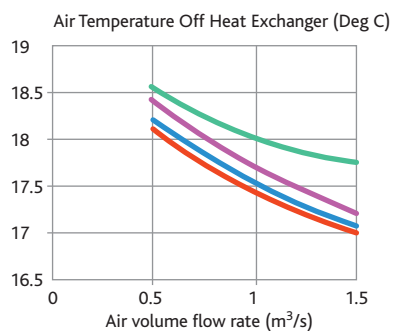
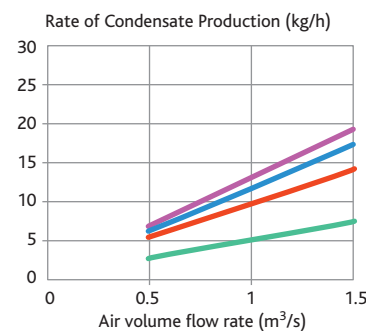
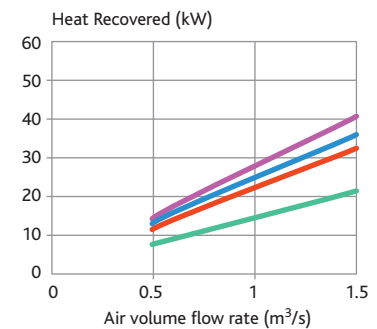
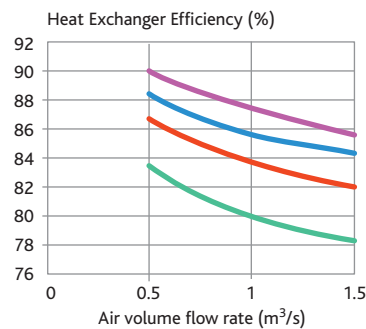

### HEATING COIL DATA LPHW

LPHW Deg C	Airflow (m³/s)	Output (kW)	Air Off Temp (C*)	Water flow (l/s)	Coil ΔP (kPa)	Pipe Connection (mm)	Valve ΔP (kPa)	Valve Type
LPHW 82/71	1.1	26.7	30.0	0.59	13.4	22	20	2 Port
	0.83	23.2	33.3	0.51	9.7	22	20	
	0.55	18.2	37.5	0.39	5.9	22	20	
	0.275	12.3	47.4	0.27	3.8	22	20	
LPHW 80/60	1.1	21.6	26.4	0.27	2.6	22	20	2 Port
	0.83	18.8	28.9	0.23	1.9	22	20	
	0.55	14.7	32.3	0.18	1.2	22	20	
	0.275	10.0	40.3	0.12	0.7	22	20	
LPHW 60/40	1.1	12.5	19.5	0.15	0.8	22	20	2 Port
	0.83	10.9	21.0	0.13	0.6	22	20	
	0.55	8.5	22.9	0.10	0.4	22	20	
	0.275	5.8	27.6	0.07	0.2	22	20	

\*Nb Limited to 30 Deg C for Ecosmart Units. Data based on 10 Deg C Air On temperature.

# XBC85 HORIZONTAL HEAT EXCHANGE UNITS

## PERFORMANCE & TECHNICAL INFORMATION

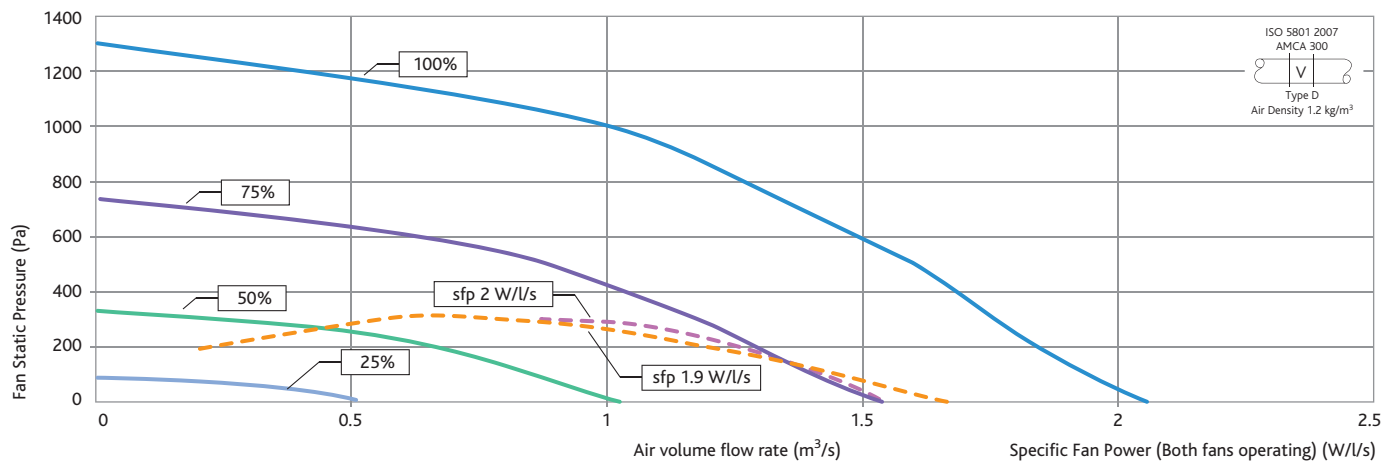

### XBC85 HORIZONTAL UNIT PERFORMANCE

Fan Speed		External Static Pressure (Pa)								Fan Speed		External Static Pressure (Pa)										
		0	50	100	150	200	300	400	500			0	50	100	150	200	300	400	500			
100%	Airflow (m³/s)	2.05	1.99	1.94	1.89	1.84	1.76	1.68	1.60	50%	Airflow (m³/s)	1.02	0.93	0.83	0.72	0.61						
	sfp (W/l/s)	2.84	2.94	3.05	3.14	3.23	3.42	3.64	3.94		sfp (W/l/s)	0.70	0.80	0.92	1.10	1.30						
	dBA@3m	50									dBA@3m	35										
75%	Airflow (m³/s)	1.54	1.47	1.40	1.34	1.28	1.14	1.00			Airflow (m³/s)	0.51	0.30									
	sfp (W/l/s)	1.60	1.69	1.80	1.88	2.02	2.30	2.71			sfp (W/l/s)	0.20	0.30									
	dBA@3m	44								dBA@3m	20											

Specific Fan Power figures are the total for both fans operating.

For accurate figures, please refer to Nuair Fan Selection Programme at [www.nuair.co.uk](http://www.nuair.co.uk)

Unit Code	Voltage / Phase / Frequency	Input Power (W)	FLC / SC (A)	Max Operating Temperature	Fan Speed (rpm)	Unit Weight (kg)	Packed Weight (kg)	Pallet / crate dimensions (mm)
XBC85-H-L**	400 / 3 / 50	6000	9.5 / 9.5	40°C	2550	760	942	3000L x 2600W x 1041H
XBC85-H-E**	400 / 3 / 50	24000*	35 / 35	40°C	2550	760	942	3000L x 2600W x 1041H
XBC85-H-N**	400 / 3 / 50	6000	9.5 / 9.5	40°C	2550	760	942	3000L x 2600W x 1041H

\*\*Add relevant code ie: BC, ES, CO or AT for control type.

\*Includes 18kW Electric Heater.

Add 'R' to relevant code for opposite configuration ie: XBC85-H-LES-R.

### FAN UNIT DIMENSIONS (mm)

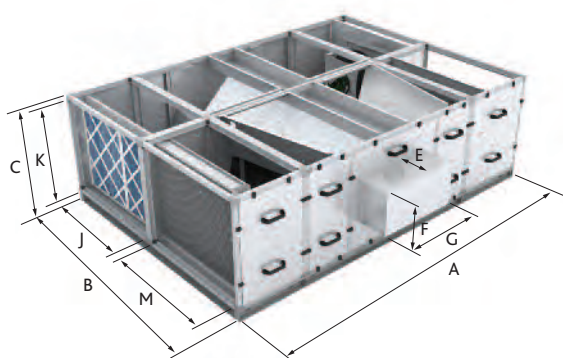

### XBC85 HORIZONTAL FAN CONFIGURATION

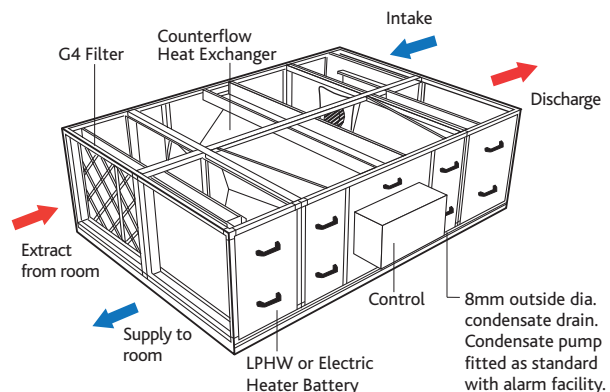

Fan Unit Dimensions (mm)			Control for all Models Dimensions (mm)			Rectangular Aperture Dimensions (mm)			Weather Roof for all Models Code XBC85-H-LESWP			Service & Maintenance Requirements		
A	B	C	E	F	G	J	K	M	H	x	W	x	L	
2800	2126	876*	250	730	800	940	740	940	125	x	2126	x	2800	The unit is designed for side access as standard and must be installed with a minimum of 650mm clearance from a wall or barrier. This will provide access to filters, coil, fan, heat exchanger, condensate tray and pump.

All models - the weather roof is part of the unit code and is factory fitted only. Example: XBC85-H-LESWP.

\*Includes unit and base rail.

# XBC85 HORIZONTAL HEAT EXCHANGE UNITS

## PERFORMANCE & TECHNICAL INFORMATION

### XBC85 HORIZONTAL FAN - SOUND DATA

Fan Speed	Sound Power Levels (dB re 1 pW)	Frequency (Hz)								Spherical dBA@3m	Fan Speed	External Static Pressure (Pa)								Spherical dBA@3m
		63	125	250	500	1000	2000	4000	8000			63	125	250	500	1000	2000	4000	8000	
100%	Induct Intake	84	85	89	88	85	82	77	73	52	50%	69	70	74	73	70	67	62	58	37
	Induct Supply	85	82	84	84	81	75	63	50			70	67	69	69	66	60	48	35	
	Induct Discharge	94	94	95	94	96	91	85	77			79	79	80	79	81	76	70	62	
	Induct Extract	86	79	84	82	78	74	66	65			71	64	69	67	63	59	51	50	
	Casing Radiated	84	76	80	69	63	58	60	48			69	61	65	54	48	43	45	33	
75%	Induct Intake	78	79	83	82	79	76	71	67	46	25%	57	58	62	61	58	55	50	46	25
	Induct Supply	79	76	78	78	75	69	57	44			58	55	57	57	54	48	36	23	
	Induct Discharge	88	88	89	88	90	85	79	71			67	67	68	67	69	64	58	50	
	Induct Extract	80	73	78	76	72	68	60	59			59	52	57	55	51	47	39	38	
	Casing Radiated	78	70	74	63	57	52	54	42			57	49	53	42	36	31	33	21	

\*Casing Radiated (Breakout).

### ATTENUATOR (SIDE BY SIDE) DIMENSIONS (mm), DYNAMIC INSERTION LOSS (dB) & WEIGHTS (kg)

Attenuator* Code	Attenuator Dimensions			Dynamic Insertion Loss (dB)								Attenuator Weight (kg)	Packed Weight (kg)
	Length	Width	Height**	63	125	250	500	1000	2000	4000	8000		
XBC85-H-SIL900	900	2000	876	0	6	8	18	22	20	16	15	185	190
XBC85-H-SIL900WP	900	2000	1001	0	6	8	18	22	20	16	15	190	195

\*Attenuator sections are side by side, one piece modules. \*\*Includes 76mm base frame.

### COUNTERFLOW HEAT EXCHANGER EFFICIENCY (%)

Performance based on:  
Indoor Conditions 21 Deg C / 50 % RH

#### Key to performance curves

- Intake Temperature (Deg C)
- 5 Deg C Intake Typically Specified Values
- 3 Deg C Intake Typically Specified Values
- 1 Deg C Intake Typically Specified Values
- 6 Deg C Approx. Average outdoor temperature (UK heating season)

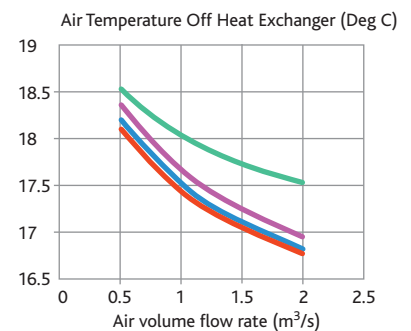
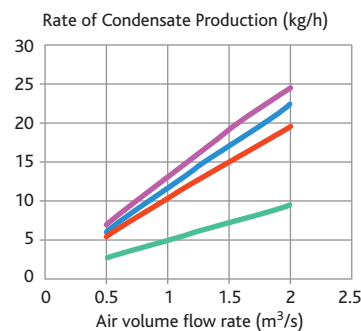
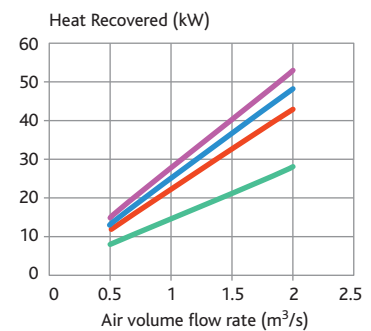
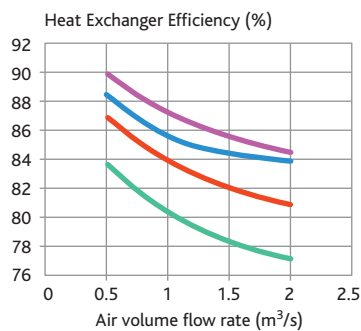

### HEATING COIL DATA LPHW

LPHW Deg C	Airflow (m³/s)	Output (kW)	Air Off Temp (C*)	Water flow (l/s)	Coil ΔP (kPa)	Pipe Connection (mm)	Valve ΔP (kPa)	Valve Type
LPHW 82/71	1.5	36.3	30.0	0.81	13.1	22	20	2 Port
	1.1	31.6	33.9	0.69	9.4	22	20	
	0.75	24.7	37.4	0.54	5.8	22	20	
LPHW 80/60	1.5	29.4	26.3	0.37	2.6	22	20	2 Port
	1.1	25.6	29.4	0.31	1.9	22	20	
	0.75	20.0	32.2	0.24	1.1	22	20	
LPHW 60/40	1.5	17.1	19.5	0.20	0.8	22	20	2 Port
	1.1	14.8	21.2	0.17	0.6	22	20	
	0.75	11.6	22.9	0.13	0.4	22	20	

\*Nb Limited to 30 Deg C for Ecosmart Units. Data based on 10 Deg C Air On temperature.

# XBC75 VERTICAL HEAT EXCHANGE UNITS

## PERFORMANCE & TECHNICAL INFORMATION

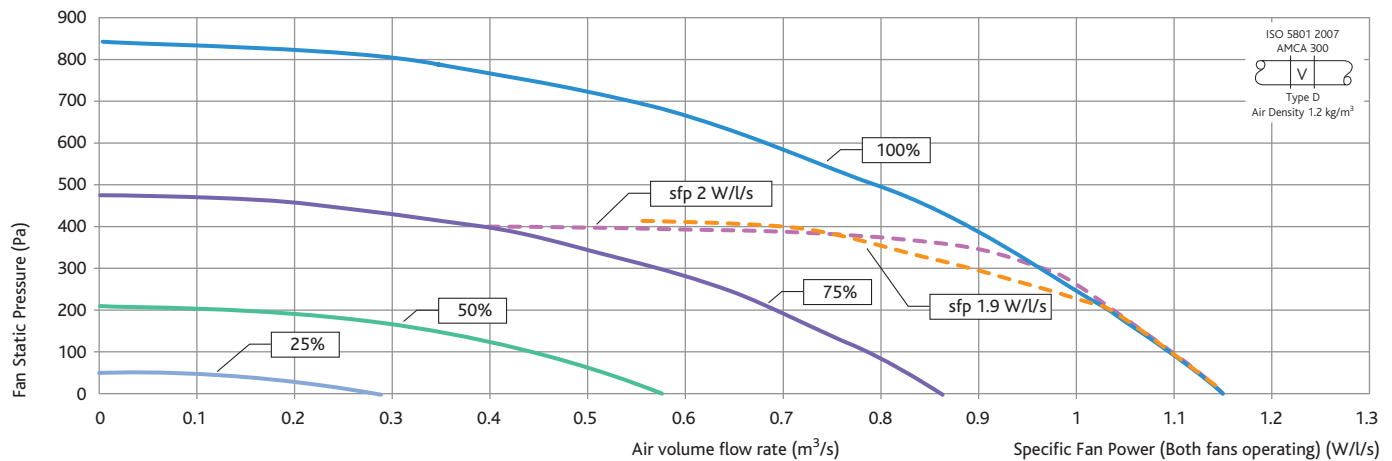

### XBC75 VERTICAL UNIT PERFORMANCE

Fan Speed	External Static Pressure (Pa)	Fan Speed								Fan Speed	External Static Pressure (Pa)												
		0	50	100	200	300	400	500	600			0	50	100	200	300	400	500	600				
100%	Airflow (m³/s)	1.15	1.13	1.10	1.04	0.97	0.89	0.80	0.68	50%	Airflow (m³/s)	0.58	0.52	0.45	0.15								
	sfp (W/l/s)	1.57	1.64	1.74	1.90	2.06	2.22	2.41	2.74		sfp (W/l/s)	0.38	0.47	0.55	1.36								
	dBA@3m	36									dBA@3m	21											
75%	Airflow (m³/s)	0.86	0.83	0.78	0.69	0.57	0.38					25%	Airflow (m³/s)	0.29									
	sfp (W/l/s)	0.89	0.97	1.07	1.21	1.41	2.01						sfp (W/l/s)	0.2 (approx)									
	dBA@3m	30								dBA@3m	<20												

Specific Fan Power figures are the total for both fans operating.

For accurate figures, please refer to Nuair Fan Selection Programme at [www.nuair.co.uk](http://www.nuair.co.uk)

Unit Code	Voltage / Phase / Frequency	Input Power (W)	FLC / SC (A)	Max Operating Temperature	Fan Speed (rpm)	Unit Weight (kg)	Packed Weight (kg)	Pallet / crate dimensions (mm)
XBC75-V-L**	400 / 3 / 50	2100	3.5 / 3.5	40°C	2140	630	722	2800L x 1200W x 1581H
XBC75-V-E**	400 / 3 / 50	14100*	21 / 21	40°C	2140	630	722	2800L x 1200W x 1581H
XBC75-V-N**	400 / 3 / 50	2100	3.5 / 3.5	40°C	2140	630	722	2800L x 1200W x 1581H

\*\*\*Add relevant code ie: BC, ES, CO or AT for control type.

\*Includes 12kW Electric Heater.

Add 'R' to relevant code for opposite configuration ie: XBC75-V-LES-R.

### FAN UNIT DIMENSIONS (mm)

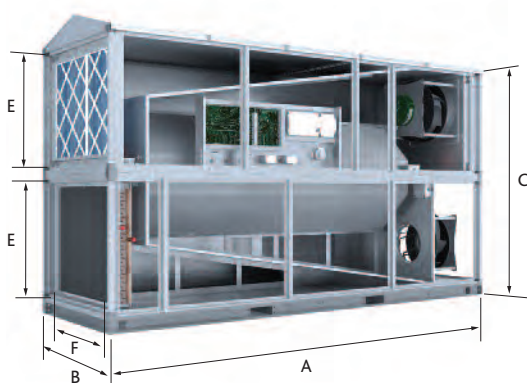

### XBC75 FAN CONFIGURATION

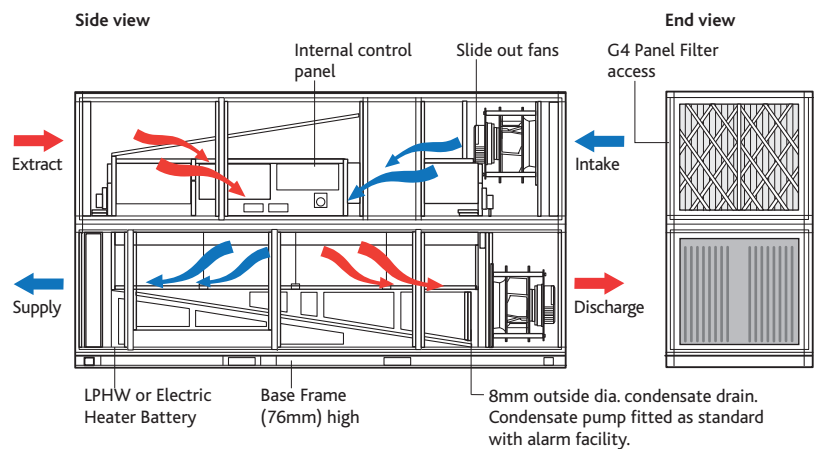

Fan Unit Dimensions (mm)			Rectangular Aperture (mm)		Weather Roof (All models) Code: XBC75-V-LESWP (mm)		Service & Maintenance Requirements
A	B	C	E	F	H x W x L		
2500	954	1416*	610	894	60 x 954 x 2500		

Weather roof is factory fitted only. Code example XBC75-V-LESWP.

\*Includes base frame (76mm) high.

The unit is designed for side access as standard and must be installed with a minimum of clearance of 650mm from a wall or barrier. This will provide access to filters, coil, fan, heat exchanger, condensate tray and pump.



# XBC75 VERTICAL HEAT EXCHANGE UNITS

## PERFORMANCE & TECHNICAL INFORMATION

### XBC75 VERTICAL FAN - SOUND DATA

Fan Speed	Sound Power Levels (dB re 1 pW)	Frequency (Hz)								Spherical dBA@3m	Fan Speed	External Static Pressure (Pa)								Spherical dBA@3m
		63	125	250	500	1000	2000	4000	8000			63	125	250	500	1000	2000	4000	8000	
100%	Induct Intake	76	75	74	77	70	64	58	54	36	50%	61	60	59	62	55	49	43	39	21
	Induct Supply	77	73	67	74	71	61	45	45			62	58	52	59	56	46	30	30	
	Induct Discharge	80	79	74	82	81	73	66	62			65	64	59	67	66	58	51	47	
	Induct Extract	74	68	66	68	63	58	59	53			59	53	51	53	48	43	39	38	
	Casing Radiated	70	62	59	57	48	40	54	33			55	47	44	42	33	25	26	18	
75%	Induct Intake	70	69	68	71	64	58	52	48	30	25%	49	48	47	50	43	37	31	27	<20
	Induct Supply	71	67	61	68	65	55	39	39			50	46	40	47	44	34	18	18	
	Induct Discharge	74	73	68	76	75	67	60	56			53	52	47	55	54	46	39	35	
	Induct Extract	68	62	60	62	57	52	48	47			47	41	39	41	36	31	27	26	
	Casing Radiated	64	56	53	51	42	34	35	27			43	35	32	30	21	<20	<20	<20	

\*Casing Radiated (Breakout).

### ATTENUATOR DOUBLE DECK DIMENSIONS (mm), DYNAMIC INSERTION LOSS (dB) & WEIGHTS (kg)

Attenuator* Code	Attenuator Dimensions			Dynamic Insertion Loss (dB)								Attenuator Weight (kg)	Packed Weight (kg)
	Length	Width	Height**	63	125	250	500	1000	2000	4000	8000		
XBC75-V-SIL900	900	954	1416	0	6	8	18	22	20	16	15	180	190
XBC75-V-SIL900WP	900	954	1476	0	6	8	18	22	20	16	15	185	195

\*Attenuator sections are double deck, one piece module. \*\*Includes 76mm base frame.

### COUNTERFLOW HEAT EXCHANGER EFFICIENCY (%)

Performance based on:  
Indoor Conditions 21 Deg C / 50 % RH

#### Key to performance curves

- Intake Temperature (Deg C)
- 5 Deg C Intake Typically Specified Values
- 3 Deg C Intake Typically Specified Values
- 1 Deg C Intake Typically Specified Values
- 6 Deg C Approx. Average outdoor temperature (UK heating season)

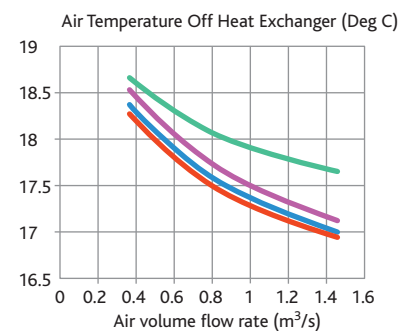
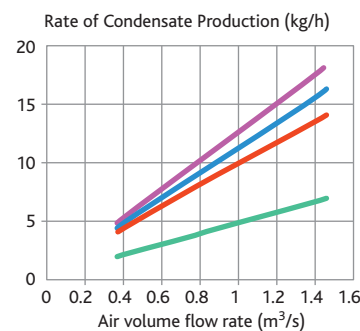
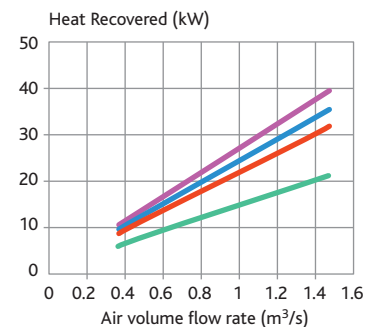
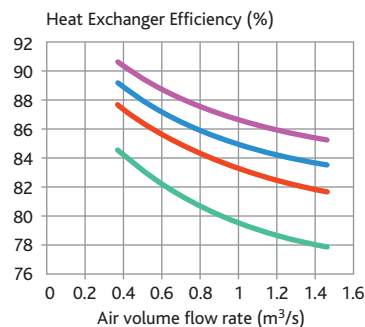

### HEATING COIL DATA LPHW

LPHW Deg C	Airflow (m³/s)	Output (kW)	Air Off Temp (C*)	Water flow (l/s)	Coil ΔP (kPa)	Pipe Connection (mm)	Valve ΔP (kPa)	Valve Type
LPHW 82/71	1.1	26.7	30.0	0.59	13.4	22	20	2 Port
	0.83	23.2	33.3	0.51	9.7	22	20	
	0.55	18.2	37.5	0.39	5.9	22	20	
	0.275	12.3	47.4	0.27	3.8	22	20	
LPHW 80/60	1.1	21.6	26.4	0.27	2.6	22	20	2 Port
	0.83	18.8	28.9	0.23	1.9	22	20	
	0.55	14.7	32.3	0.18	1.2	22	20	
	0.275	10.0	40.3	0.12	0.7	22	20	
LPHW 60/40	1.1	12.5	19.5	0.15	0.8	22	20	2 Port
	0.83	10.9	21.0	0.13	0.6	22	20	
	0.55	8.5	22.9	0.10	0.4	22	20	
	0.275	5.8	27.6	0.07	0.2	22	20	

\*Nb Limited to 30 Deg C for Ecosmart Units. Data based on 10 Deg C Air On temperature.

# XBC85 VERTICAL HEAT EXCHANGE UNITS

## PERFORMANCE & TECHNICAL INFORMATION

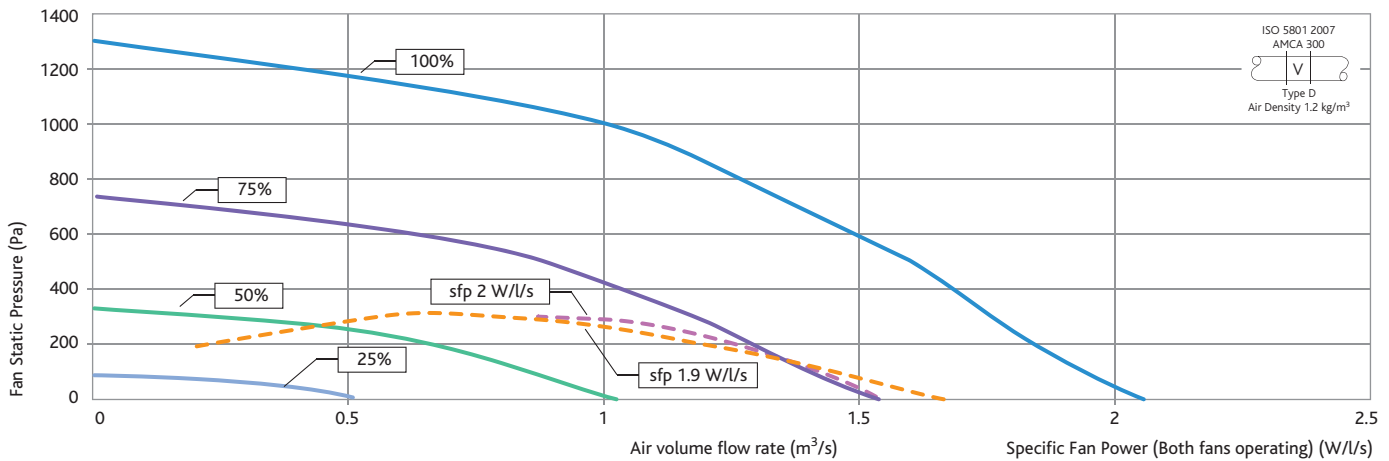

### XBC85 UNIT PERFORMANCE

Fan Speed	External Static Pressure (Pa)	External Static Pressure (Pa)								Fan Speed	External Static Pressure (Pa)										
		0	50	100	150	200	300	400	500			0	50	100	150	200	300	400	500		
100%	Airflow (m³/s)	2.05	1.99	1.94	1.89	1.84	1.76	1.68	1.60	50%	Airflow (m³/s)	1.02	0.93	0.83	0.72	0.61					
	sfp (W/l/s)	2.84	2.94	3.05	3.14	3.23	3.42	3.64	3.94		sfp (W/l/s)	0.70	0.80	0.92	1.10	1.30					
	dBA@3m	50									dBA@3m	35									
75%	Airflow (m³/s)	1.54	1.47	1.40	1.34	1.28	1.14	1.00			25%	Airflow (m³/s)	0.51	0.30							
	sfp (W/l/s)	1.60	1.69	1.80	1.88	2.02	2.30	2.71				sfp (W/l/s)	0.20	0.30							
	dBA@3m	44								dBA@3m		20									

Specific Fan Power figures are the total for both fans operating.

For accurate figures, please refer to Nuaire Fan Selection Programme at [www.nuaire.co.uk](http://www.nuaire.co.uk)

Unit Code	Voltage / Phase / Frequency	Input Power (W)	FLC / SC (A)	Max Operating Temperature	Fan Speed (rpm)	Unit Weight (kg)	Packed Weight (kg)	Pallet / crate dimensions (mm)
XBC85-V-L**	400 / 3 / 50	6000	9.5 / 9.5	40°C	2550	780	880	3300L x 1200W x 1841H
XBC85-V-E**	400 / 3 / 50	24000*	35 / 35	40°C	2500	780	880	3300L x 1200W x 1841H
XBC85-V-N**	400 / 3 / 50	6000	9.5 / 9.5	40°C	2500	780	880	3300L x 1200W x 1841H

\*\*Add relevant code ie: BC, ES, CO or AT for control type.

\*Includes 18kW Electric Heater.

Add 'R' to relevant code for opposite configuration ie: XBC85-V-LES-R.

### FAN UNIT DIMENSIONS (mm)

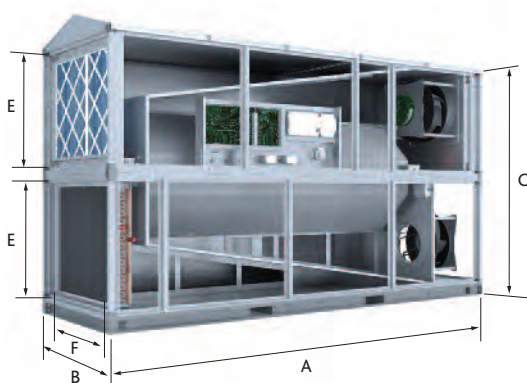

### XBC85 FAN CONFIGURATION

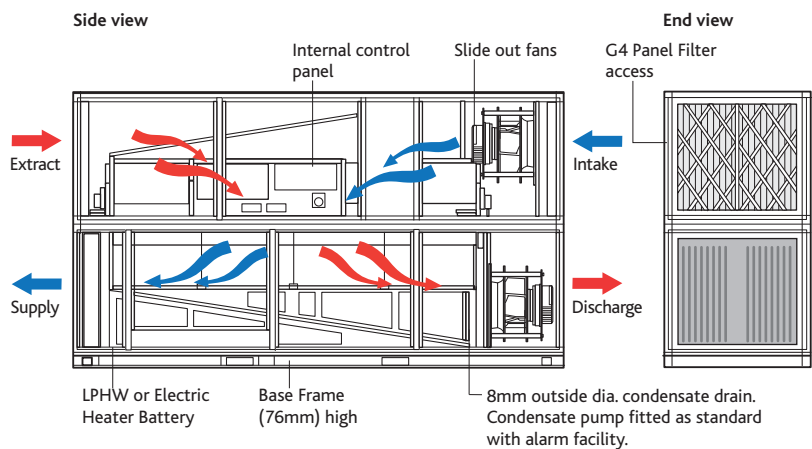

Fan Unit Dimensions (mm)			Rectangular Aperture (mm)		Weather Roof (All models) Code: XBC85-V-LESWP (mm)		Service & Maintenance Requirements
A	B	C	E	F	H x W x L		
3000	1000	1676*	740	940	65 x 1000 x 3000		

Weather roof is factory fitted only. Code example XBC85-V-LESWP.

\*Includes base frame (76mm) high.

**Service & Maintenance Requirements**  
The unit is designed for side access as standard and must be installed with a minimum of clearance of 650mm from a wall or barrier. This will provide access to filters, coil, fan, heat exchanger, condensate tray and pump.

# XBC85 VERTICAL HEAT EXCHANGE UNITS

## PERFORMANCE & TECHNICAL INFORMATION

### XBC85 FAN - SOUND DATA

Fan Speed	Sound Power Levels (dB re 1 pW)	Frequency (Hz)								Spherical dBA@3m	Fan Speed	External Static Pressure (Pa)								Spherical dBA@3m
		63	125	250	500	1000	2000	4000	8000			63	125	250	500	1000	2000	4000	8000	
100%	Induct Intake	81	82	93	83	79	76	73	68	50	50%	66	67	78	68	64	61	58	53	35
	Induct Supply	81	80	86	80	80	73	60	51			66	65	71	65	65	58	45	36	
	Induct Discharge	84	86	93	88	90	85	81	76			69	71	78	73	75	70	66	61	
	Induct Extract	78	75	85	74	72	70	69	67			63	60	70	59	57	55	54	52	
	Casing Radiated	74	69	78	63	57	52	56	47			59	54	63	48	42	37	41	32	
75%	Induct Intake	75	76	87	77	73	70	67	62	44	25%	51	52	63	53	49	46	43	38	20
	Induct Supply	75	74	80	74	74	67	54	45			51	50	56	50	50	43	30	21	
	Induct Discharge	78	80	87	82	84	79	75	70			54	56	63	58	60	55	51	46	
	Induct Extract	72	69	79	68	66	64	63	61			48	45	55	44	42	40	39	37	
	Casing Radiated	68	63	72	57	51	46	50	41			44	39	48	33	27	22	26	17	

\*Casing Radiated (Breakout).

### ATTENUATOR DOUBLE DECK DIMENSIONS (mm), DYNAMIC INSERTION LOSS (dB) & WEIGHTS (kg)

Attenuator* Code	Attenuator Dimensions			Dynamic Insertion Loss (dB)								Attenuator Weight (kg)	Packed Weight (kg)
	Length	Width	Height**	63	125	250	500	1000	2000	4000	8000		
XBC85-V-SIL900	900	1000	1676	0	6	8	18	22	20	16	15	185	190
XBC85-V-SIL900WP	900	1000	1741	0	6	8	18	22	20	16	15	190	195

\*Attenuator sections are double deck, one piece module. \*\*Includes 76mm base frame.

### COUNTERFLOW HEAT EXCHANGER EFFICIENCY (%)

Performance based on:  
Indoor Conditions 21 Deg C / 50 % RH

#### Key to performance curves

- Intake Temperature (Deg C)
- 5 Deg C Intake Typically Specified Values
- 3 Deg C Intake Typically Specified Values
- 1 Deg C Intake Typically Specified Values
- 6 Deg C Approx. Average outdoor temperature (UK heating season)

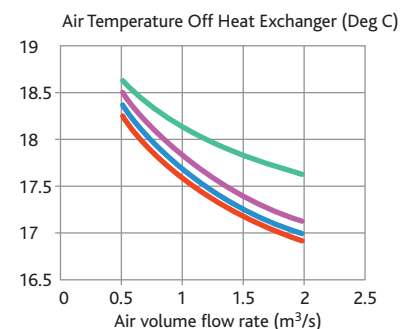
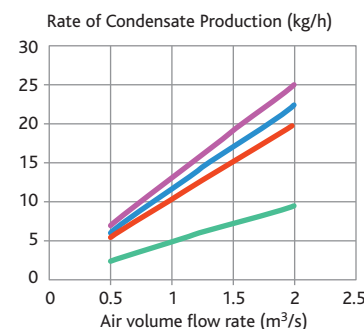
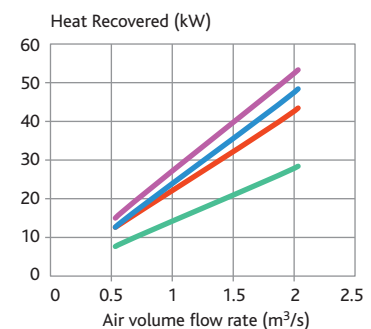
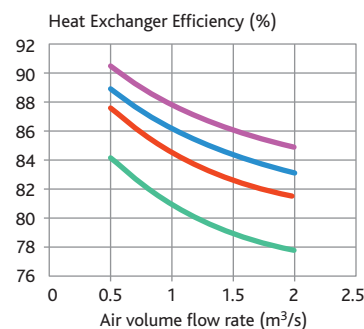

### HEATING COIL DATA LPHW

LPHW Deg C	Airflow (m³/s)	Output (kW)	Air Off Temp (C*)	Water flow (l/s)	Coil ΔP (kPa)	Pipe Connection (mm)	Valve ΔP (kPa)	Valve Type
LPHW 82/71	1.5	36.3	30.0	0.81	13.1	22	20	2 Port
	1.1	31.6	33.9	0.69	9.4	22	20	
	0.75	24.7	37.4	0.54	5.8	22	20	
LPHW 80/60	1.5	29.4	26.3	0.37	2.6	22	20	2 Port
	1.1	25.6	29.4	0.31	1.9	22	20	
	0.75	20.0	32.2	0.24	1.1	22	20	
LPHW 60/40	1.5	17.1	19.5	0.20	0.8	22	20	2 Port
	1.1	14.8	21.2	0.17	0.6	22	20	
	0.75	11.6	22.9	0.13	0.4	22	20	

\*Nb Limited to 30 Deg C for Ecosmart Units. Data based on 10 Deg C Air On temperature.

# XBOXER XBC75 & 85 HORIZONTAL UNITS

## ANCILLARIES

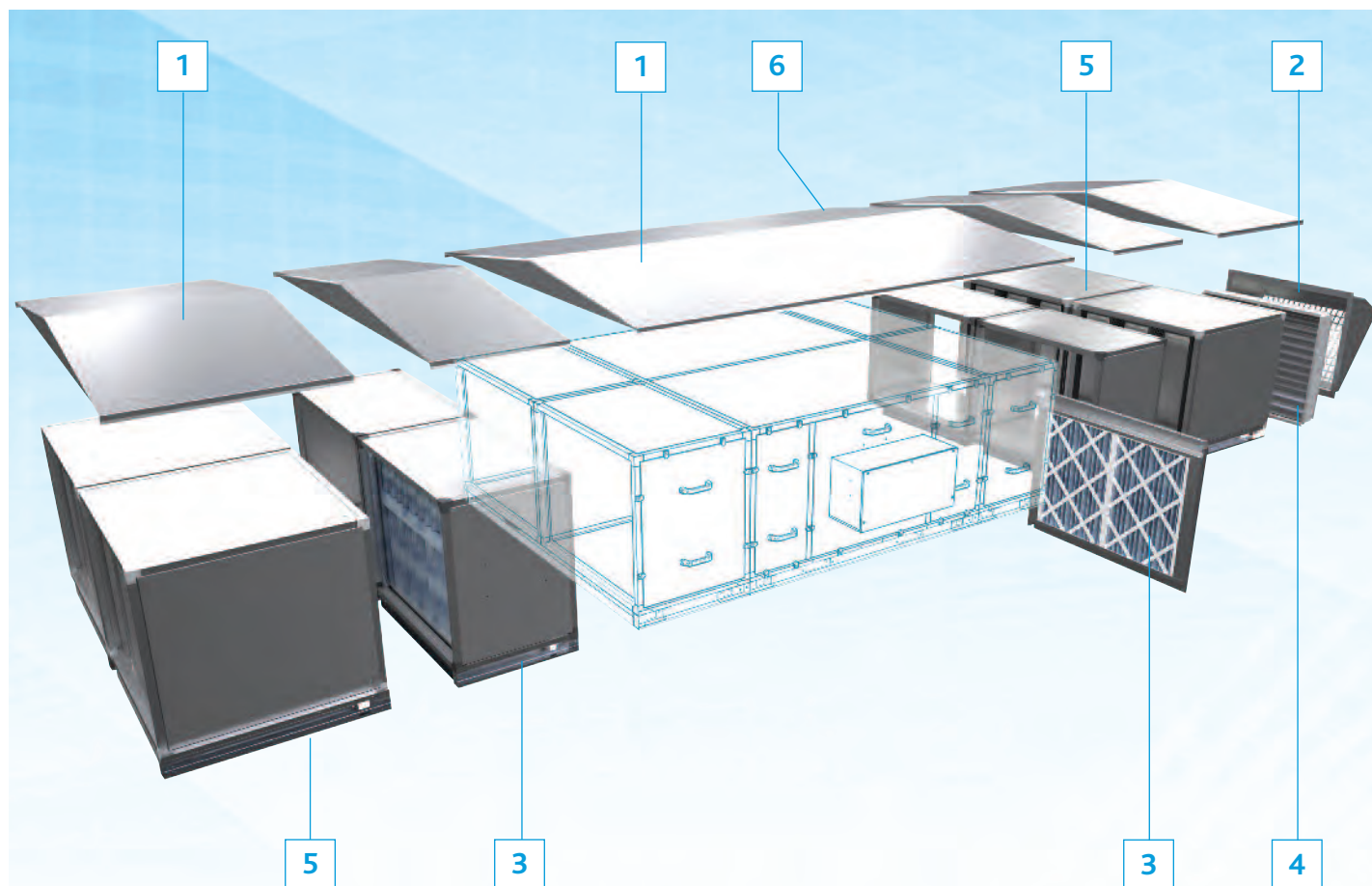

### QUICK SELECTION GUIDE XBC75 & 85 HORIZONTAL UNITS - ANCILLARIES

XBC Unit Size	Format	1		3			
		Weather Kit BC, ES, CO & AT models	Weather Terminal	Filter & Module Options (All are side by side c/w empty module + base frame)			
				F7 Bag / G4 Panel	G4 Bag	Bag / Panel WP	Bag WP
XBC75	Horizontal	XBC75-H-***WP	XBC75-H-RT	XBC75-F7B/G4P-H	XBC75-G4B-H	XBC75-F7B/G4B-HWP	XBC75-G4B-HWP
XBC75	Horizontal (-R)	XBC75-H-***RWP	XBC75-H-RT	XBC75-F7B/G4P-HR	XBC75-G4B-HR	XBC75-F7B/G4B-HRWP	XBC75-G4B-HRWP
XBC85	Horizontal	XBC85-H-***WP	XBC85-H-RT	XBC85-F7B/G4P-H	XBC85-G4B-H	XBC85-F7B/G4B-HWP	XBC85-G4B-HWP
XBC85	Horizontal (-R)	XBC85-H-***RWP	XBC85-H-RT	XBC85-F7B/G4P-HR	XBC85-G4B-HR	XBC85-F7B/G4B-HRWP	XBC85-G4B-HRWP

\*Weather roof is part of the unit code i.e. XBC75-H-LATWP. (Applies to all models).

Please note the 'H' models also have additional control cover.

XBC Unit Size	Format	4			5	
		Motorised Dampers (internal)** 230V (ES models only) Damper with 230V actuator	Shut-off Damper (CO models only) 24V non-modulating	No actuator (BC models only) Extended spindle	2x Matching Silencers (side by side)	
					Internal 900mm length***	External 900mm length***
XBC75	Horizontal	XBC75-H-MD230V motor open/closed	XBC75-H-MD24V	XBC75-H-MD-NC	XBC75-H-SIL900	XBC75-H-SIL900-WP
XBC85	Horizontal	XBC85-H-MD230V motor open/closed	XBC85-H-MD24V	XBC85-H-MD-NC	XBC85-H-SIL900	XBC85-H-SIL900-WP

\*\*Supplied loose, suitable for ES models.

Dampers for external use order Code: XBC\*\*-RT (Roof Terminal).

\*\*\*For other lengths contact Nuair.

XBC Unit Size	Format	6					
		Frost Coils* - Side by side complete with empty module and base frame					
		BC Models		ES Models		CO or AT Models	
		LPHW	Electric	LPHW	Electric	LPHW	Electric
XBC75	Horizontal	XBC75-FCL-LNC-H	XBC85-FCE-LNC-H	XBC75-FCL-LES-H	XBC75-FCE-LES-H	XBC75-FCL-L**-H	XBC75-FCE-L**-H
XBC75	Horizontal (-R)	XBC75-FCL-RNC-H	XBC85-FCE-RNC-H	XBC75-FCL-RES-H	XBC75-FCE-RES-H	XBC75-FCL-R**-H	XBC75-FCE-R**-H
XBC85	Horizontal	XBC85-FCL-LNC-H	XBC85-FCE-LNC-H	XBC85-FCL-LES-H	XBC85-FCE-LES-H	XBC85-FCL-L**-H	XBC85-FCE-L**-H
XBC85	Horizontal (-R)	XBC85-FCL-RNC-H	XBC85-FCE-RNC-H	XBC85-FCL-RES-H	XBC85-FCE-RES-H	XBC85-FCL-R**-H	XBC85-FCE-R**-H

\*All Frost Coils are for internal use. For external applications please add 'WP' to code i.e. XBC75-FCE-RAT-HWP.

# XBOXER XBC75 & 85 VERTICAL UNITS

## ANCILLARIES

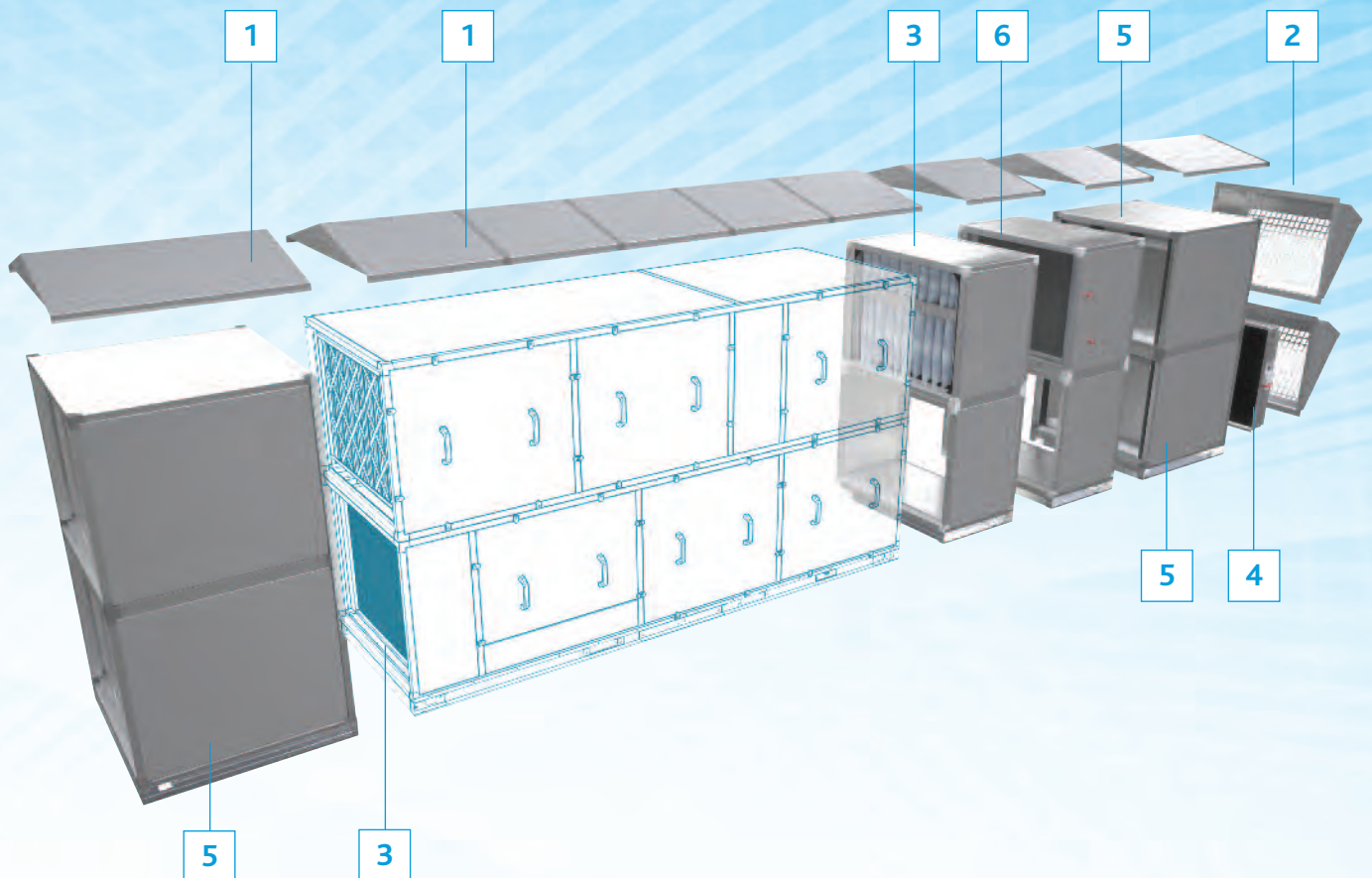

### QUICK SELECTION GUIDE XBC75 & 85 VERTICAL UNITS - ANCILLARIES

XBC Unit Size	Format	1		3			
		Weather Kit BC, ES & AT models	Weather Terminal	Filter & Module Options (All are double deck c/w empty module + base frame)	F7 Bag / G4 Panel	Bag	Bag / Panel WP
XBC75	Vertical (standard)	XBC75-V-***WP	XBC75-RT	XBC75-F7B/G4P	XBC75-G4B	XBC75-F7B/G4P-WP	XBC75-G4B-WP
XBC75	Vertical (-R)	XBC75-V-***-RWP	XBC75-RT	XBC75-F7B/G4P-R	XBC75-G4B-R	XBC75-F7B/G4P-RWP	XBC75-G4B-RWP
XBC85	Vertical (standard)	XBC85-V-***WP	XBC85-RT	XBC85-F7B/G4P	XBC85-G4B	XBC85-F7B/G4P-WP	XBC85-G4B-WP
XBC85	Vertical (-R)	XBC85-V-***-RWP	XBC85-RT	XBC85-F7B/G4P-R	XBC85-G4B-R	XBC85-F7B/G4P-RWP	XBC85-G4B-RWP

\*All models-weather roof is part of the unit code i.e. XBC85-V-LATWP.

XBC Unit Size	Format	4			5	
		Motorised Dampers (internal)** 230V (ES models only) Damper with 230V actuator	Shut-off Damper (CO models only) 24V non-modulating	No actuator (BC models only) Extended spindle	2x Matching Silencers (double deck) Internal 900mm length***	External 900mm length***
XBC75	Vertical	XBC75-MD230V motor open/closed	XBC75-MD24V	XBC75-MD-NC	XBC75-V-SIL900	XBC75-V-SIL900-WP
XBC85	Vertical	XBC85-MD230V motor open/closed	XBC85-MD24V	XBC85-MD-NC	XBC85-V-SIL900	XBC85-V-SIL900-WP

\*\*Supplied loose, suitable for ES models.

Dampers for external use order Code: XBC\*\*-RT (Roof Terminal).

XBC Unit Size	Format	6					
		Frost Coils* - Double decked complete with empty lower module and base frame					
		BC Models		ES Models		CO or AT Models	
LPHW	Electric	LPHW	Electric	LPHW	Electric		
XBC75	Vertical (standard)	XBC75-FCL-LNC-V	XBC75-FCE-LNC-V	XBC75-FCL-LES-V	XBC75-FCE-LES-V	XBC75-FCL-L**-V	XBC75-FCE-L**-V
XBC75	Vertical (-R)	XBC75-FCL-RNC-V	XBC75-FCE-RNC-V	XBC75-FCL-RES-V	XBC75-FCE-RES-V	XBC75-FCL-R**-V	XBC75-FCE-R**-V
XBC85	Vertical (standard)	XBC85-FCL-LNC-V	XBC85-FCE-LNC-V	XBC85-FCL-LES-V	XBC85-FCE-LES-V	XBC85-FCL-L**-V	XBC85-FCE-L**-V
XBC85	Vertical (-R)	XBC85-FCL-RNC-V	XBC85-FCE-RNC-V	XBC85-FCL-RES-V	XBC85-FCE-RES-V	XBC85-FCL-R**-V	XBC85-FCE-R**-V

\*All Frost Coils are for internal use. For external applications please add 'WP' to code i.e. XBC85-FCE-RAT-VWP.

# XBC75-85 HEAT EXCHANGE UNITS

## CONSULTANTS SPECIFICATION

### OPERATION

The supply and extract ventilation unit shall be configured as indicated on the drawings. The heat recovery ventilation unit shall enable the room design conditions to be maintained by the effective and continuous control of ventilation rate, the integrated counterflow heat exchanger matrix and bypass, and LPHW heating facility.

The ventilation unit shall automatically vary the ventilation rate in the space dependent upon the signals received from the interconnected sensors and user interface (where provided). When signals are received, the unit shall vary its fan speeds proportionally until the desired set points are met.

The unit shall have the facility to commission the supply and extract fans individually via inbuilt maximum, minimum and offset speed adjustments. Each fan shall have stepless variable speed control (20 – 100% of maximum).

The unit shall be the XBC75-85\*\*\* as manufactured by Nuair.

### UNIT SPECIFICATION

The heat recovery ventilation unit shall have a maximum depth of 876mm (XBC75/85-H), 1416mm (XBC75-V) and 1676mm (XBC85-V) including base frame.

The one-piece ventilation unit shall be constructed with double skinned Aluzinc panels on an aluminium Pentapost frame with integral acoustic mineral fibre ensuring low breakout noise levels. The unit shall incorporate a high efficiency aluminium counterflow plate heat exchanger matrix with a thermal efficiency of up to 92%, fitted with a segmented 100% bypass facility and actuator (patent app.for) operating under automatic control. The automatic operation of the XBC bypass is determined by an algorithm that varies output based on temperatures, and whether the control system has been set to prioritise heating, ventilation or cooling.

The unit shall be protected from airborne contamination by high capacity pleated G4 panel filters (supply and extract).

The unit shall be fitted with ErP 2016 rated, low energy, high efficiency IP54 EC motorised fans providing low specific fan powers and stepless speed control, without tonal noise generation. Fan/motor assemblies have sealed for life bearings with an anticipated working life of 70,000 hours (L10) and shall be suitable for single phase supply.

Impellers shall be of high efficiency, performance and sound optimised backward curved design.

The unit shall be fitted with a LPHW heater battery (code example XBC75-V-LES), complete with factory fitted valve and actuator, terminating at the unit casing. Contact Nuair for Electric heater battery options.

The system shall have frost protection (Ecosmart models only) which shall, at temperatures below 4 degrees C, fully open the 2-port valve and only start the fan when the temperature within the chamber has risen above the designated set point.

The LPHW assembly shall be pressure tested at works to a minimum of 6 Bar. The control for the heaters shall be fully integrated and shall maintain a constant temperature\*\*\* to meet the system design requirements.

\*\*\*The heating output (LPHW or electric) is automatically regulated to control the Air - Off condition.

The unit is also available without a heater fitted (code example XBC75-V-NBC).

The unit shall be constructed with removable side panels allowing full maintenance access.

The removable panels shall provide access to the following:-

- Supply and extract fan.
- Supply and extract filter.
- Condensate tray.
- All control adjustments (where included). Vertical models only.

### UNIT CONFIGURATION

Standard Unit is supplied with internal control panel and connections on left side (refer to technical documentation). Horizontal units have externally mounted control panel. Opposite hand unit is available (example code XBC75-V-LES-R).

The ventilation unit shall comprise the following:-

Supply and extract fans, high efficiency counterflow plate heat exchanger matrix, supply and extract filters, full 100% automatic heat exchanger bypass, heating coil (as selected) & condensate drip tray, a condensate pump is installed in the unit and has an alarm function (connection by others). If the water level in the condensate tray exceeds a maximum level (for example, as a result of the discharge tube becoming blocked or frozen), the alarm contact will open. This contact is internally connected to the heat exchanger bypass actuator, and the unit will automatically be placed into bypass mode, preventing further condensate production. Unit operation will otherwise be unaffected.

Matching double skinned Pentapost construction attenuators can also be provided by Nuair.

### CODE DESCRIPTION

XBC75-V-LES-R-WP  
| | | | | | | |  
1 2 3 4 5 6 7 8

1. XBOXER
2. Counterflow heat exchanger
3. Unit size (75 & 85)
4. V = Vertical, H = Horizontal
5. Type of heater battery:  
L = LPHW, N = No heater  
E = Electric heater
6. Control type:  
AT = Ecosmart Adapt (Trend)  
CO = Ecosmart Connect  
ES = Ecosmart Classic  
BC = Basic control
7. R = Opposite configuration
8. WP = Weather roof factory fitted only.

For further details on the ErP directive please refer to [www.nuair.co.uk](http://www.nuair.co.uk)

## XBC75-85 CONTROL OPTIONS CONSULTANTS SPECIFICATION

### BASIC CONTROL OPTION

Unit is provided with side access to internal mounted basic control housing for direct supply and extract fan motor wiring and for interfacing to custom built control panels.

The basic control housing (terminal box) is provided for the connections to the fans (400V 3Ph 50Hz LNE and 2-10V), and Electric heater terminal and thermal protection (where specified).

For this option, no sensors are fitted to the unit, but note that the plate heat exchanger bypass damper actuator is included suitable for 400V standard.

Units fitted with Basic Control (code example XBC75-V-EBC) have a 2 year warranty.

### ECOSMART CLASSIC OPTION - DEMAND CONTROLLED VENTILATION

Provides the facility for energy saving via an intelligent stand-alone AHU function with local diagnostic status indication, or allows convenient integration with the client BMS with a minimal co-ordination requirement.

The factory fitted Ecosmart Classic control includes:- integral infinitely variable speed / duty control for the supply and extract fans, with independent minimum, maximum and offset adjustment for accurate commissioning.  
The control assembly is mounted internally.

The control features a run on timer and "background" ventilation function, and is provided with unit status indication, run and fail relays and interface connections for Ecosmart Classic sensors/enablers and system dampers.

The heat exchanger bypass is automatically operated according to temperature and a pre-defined strategy.

\*\*\*The heating output (LPHW or electric) is automatically regulated to control the Air - Off condition.

The Ecosmart control module can additionally be connected to provide the following integrated BMS interfaces.

- 0 - 10 volt inputs. This will enable the following functions:-  
Switch the unit ON/OFF. Variable speed / duty control, Switch from low speed to high speed, Enable heating/cooling.
- 2 No. Volt free contacts give fan run and failure unit status indication.

Units fitted with Ecosmart Classic control (code example XBC75-V-LES) have a 5 year warranty.

### ECOSMART CONNECT OPTION – ENHANCED DEMAND CONTROLLED VENTILATION

A comprehensive unit control specification - factory fitted and tested to provide guaranteed operation from a single supplier – one who will take responsibility.

The unit integrated Ecosmart Connect system provides the facility for operational efficiency and energy saving by allowing a comprehensive range of unitary control functions and / or full BMS integration (by others) via standard BACnet (MS/TP).

The system incorporates a web access enabled controller, and is augmented by application specific unit interface and diagnostic circuits.  
Controller software is optimised and pre-configured, and each unit / control assembly is fully functionally tested at works (Refer to technical documentation for full controller functional specification).

Units fitted with Ecosmart Connect control (code example XBC75-H-CO) have a 5 year warranty. (Refer to 'Description of control' for further details).

### ECOSMART ADAPT WITH TREND OPTION – ENHANCED DEMAND CONTROLLED VENTILATION

A comprehensive unit control specification - factory fitted and tested to provide guaranteed operation from a single supplier – one who will take responsibility.

The unit integrated Ecosmart Adapt system provides the facility for operational efficiency and energy saving by allowing a comprehensive range of unitary control functions and / or full BMS integration (by others) via standard BACnet IP configuration.

The system incorporates a web access enabled Trend IQ422/12/LAN/BAC/230 controller, and is augmented by application specific unit interface and diagnostic circuits. Controller software is optimised and pre-configured, and each unit / control assembly is fully functionally tested at works (Refer to technical documentation for full controller functional specification).

Units fitted with Ecosmart Adapt control (code example XBC75-V-LAT) have a 5 year warranty. (Refer to 'Description of control' for further details).

The unit shall be the XBC75-85 as manufactured by Nuair.

# XBOXER XBC75-85 HORIZONTAL & VERTICAL UNITS

## UNIT WIRING

### UNITS WITH ECOSMART CLASSIC CONTROL & LPHW COIL CONTROL (CODING EXAMPLE XBC\*\*-\*-LES)

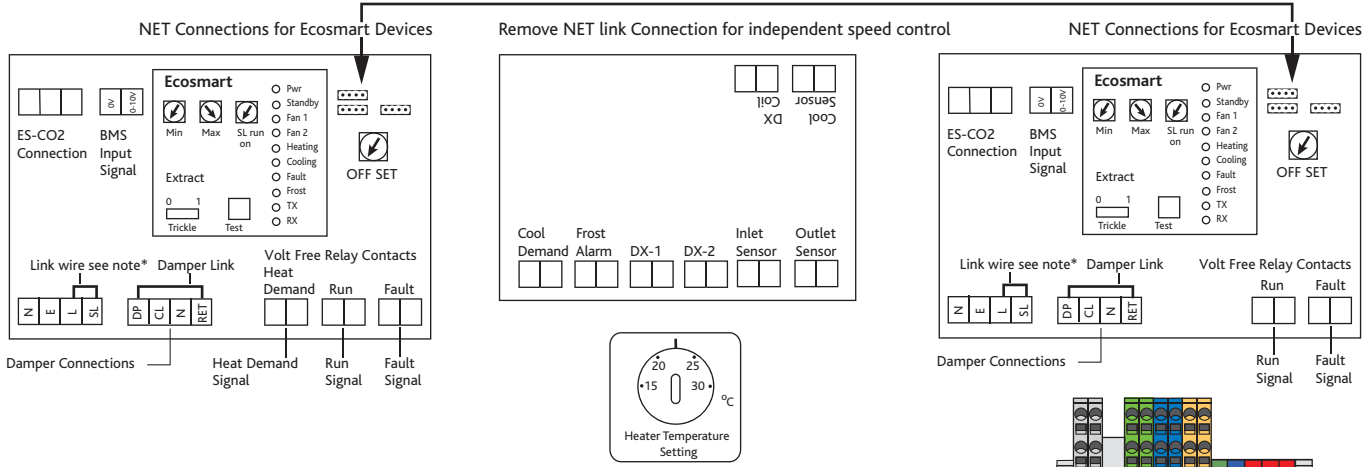

All inter-connections between circuit boards, blowers and sensors are made at the factory. This diagram only shows the essential field wiring points for clarity.

\*Remove link wire if switched live signal, an enabler or BMS signal is connected.

Note: If a damper is not fitted, connect (Factory Fitted) a link wire from OP to RET. This will cancel the delay.

#### Volt Free contacts

Note: That the volt free contacts are not fused. If these are used to power any external equipment, the installer must provide adequate fusing or other protections.

These contacts are rated at 5A resistive, 0.5A inductive. **Run connections** - These contacts are closed when the fan is running.

**Fault connections** - No fault = the contacts are closed. Fault = the contacts are opened.

**Heat demand** - contacts closed when heating is selected.

### UNITS WITH ECOSMART CONTROL & ELECTRIC HEATER (CODING EXAMPLE XBC\*\*-\*-EES)

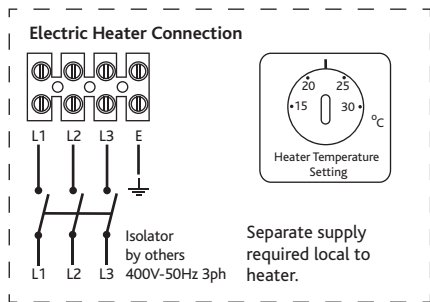
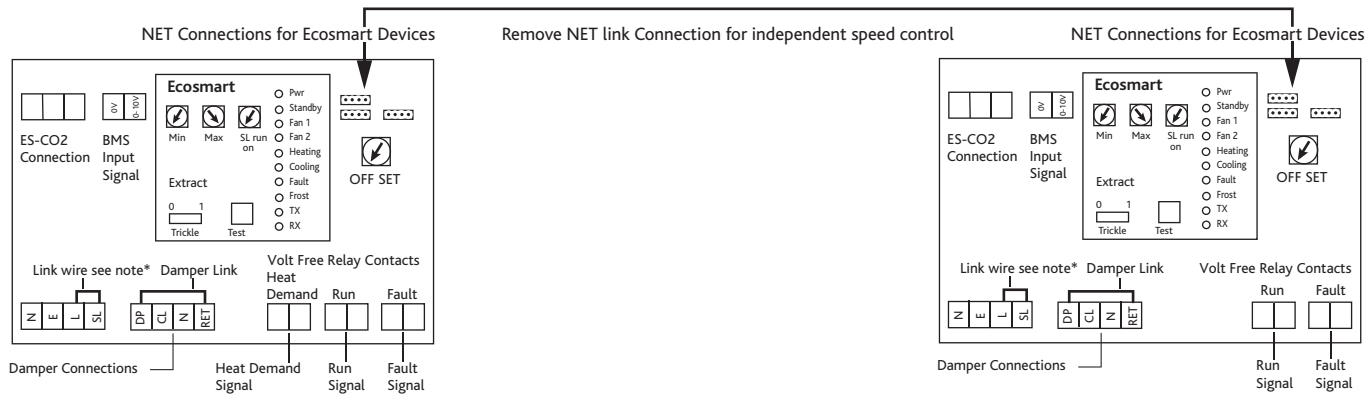

All inter-connections between circuit boards, blowers and sensors are made at the factory. This diagram only shows the essential field wiring points for clarity.

\*Remove link wire if switched live signal, an enabler or BMS signal is connected.

Note: If a damper is not fitted, connect (Factory Fitted) a link wire from OP to RET. This will cancel the delay.

#### Volt Free contacts

Note: That the volt free contacts are not fused. If these are used to power any external equipment, the installer must provide adequate fusing or other protections.

These contacts are rated at 5A resistive, 0.5A inductive. **Run connections** - These contacts are closed when the fan is running.

**Fault connections** - No fault = the contacts are closed. Fault = the contacts are opened.

**Heat demand** - contacts closed when heating is selected.

**ECOSMART WIRING** For Ecosmart Connect and Adapt Trend wiring please contact Nuair.



# XBOXER XBC75-85 HORIZONTAL & VERTICAL UNITS UNIT WIRING

## UNITS WITH ECOSMART CLASSIC FAN ONLY CONTROL (CODING EXAMPLE XBC\*\*-\*-NES)

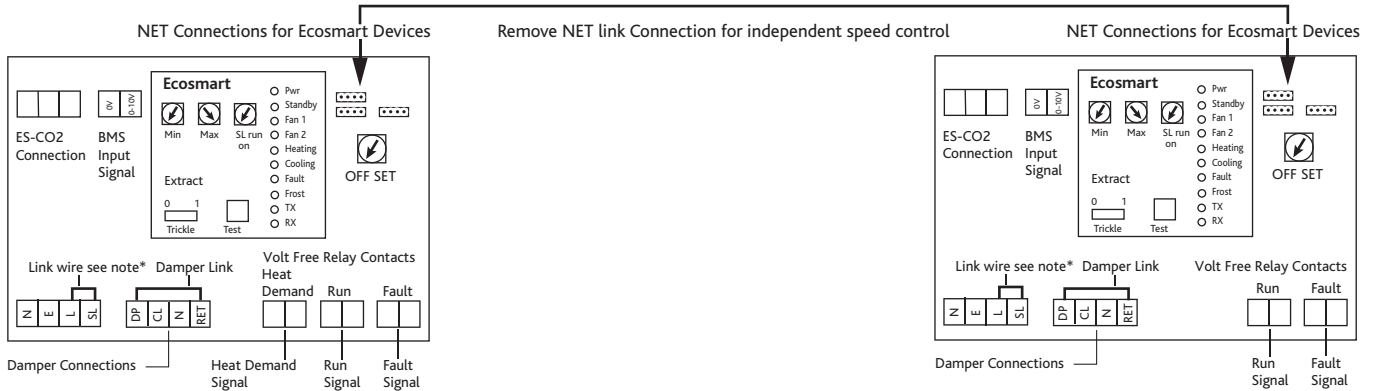

All inter-connections between circuit boards, blowers and sensors are made at the factory. This diagram only shows the essential field wiring points for clarity.  
\*Remove link wire if switched live signal, an enabler or BMS signal is connected.  
Note: If a damper is not fitted, connect (Factory Fitted) a link wire from OP to RET. This will cancel the delay.

**Volt Free contacts**  
Note: That the volt free contacts are not fused. If these are used to power any external equipment, the installer must provide adequate fusing or other protections. These contacts are rated at 5A resistive, 0.5A inductive.  
**Run connections** - These contacts are closed when the fan is running.  
**Fault connections** - No fault = the contacts are closed. Fault = the contacts are opened.  
**Heat demand** - contacts closed when heating is selected.

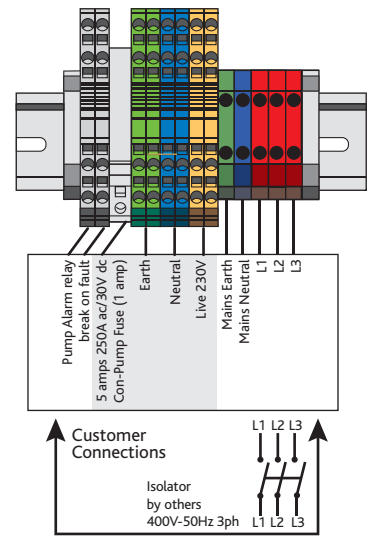

## WIRING - FOR UNITS SUPPLIED WITHOUT ECOSMART CONTROL LPHW & NO HEATER XBC75-85 ONLY

### Supply Fan

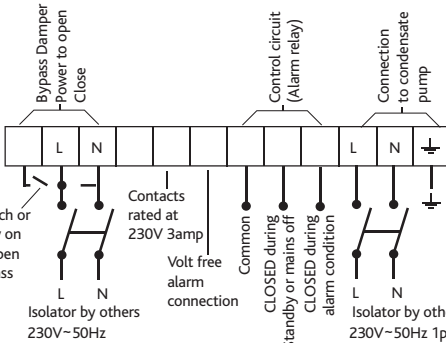
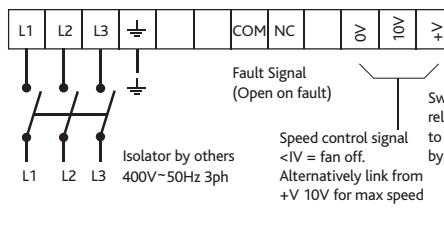

### Extract Fan

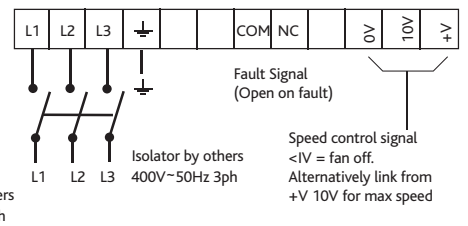

## ELECTRIC HEATER XBC75-85 ONLY

### Supply Fan

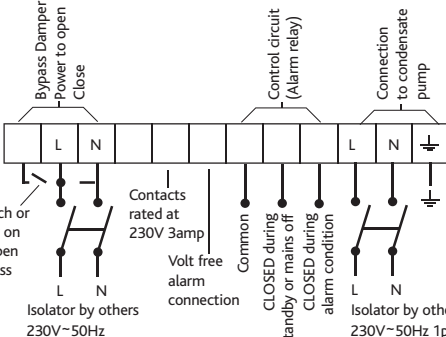
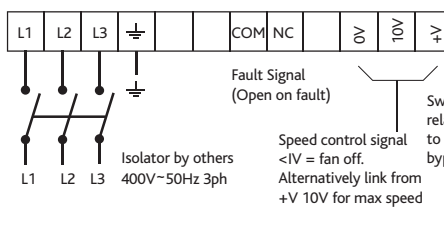

### Extract Fan

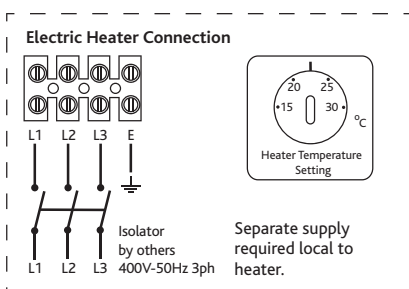
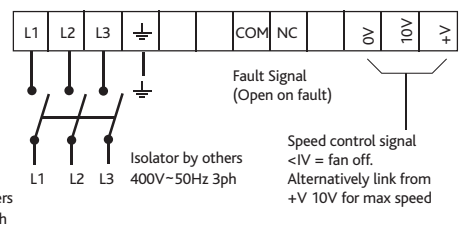

**ECOSMART WIRING** For Ecosmart Connect and Adapt Trend wiring please contact Nuair.

# CONSTANT PRESSURE FOR ECOSMART UNITS ON DEMAND VENTILATION WHEN YOU NEED IT MOST

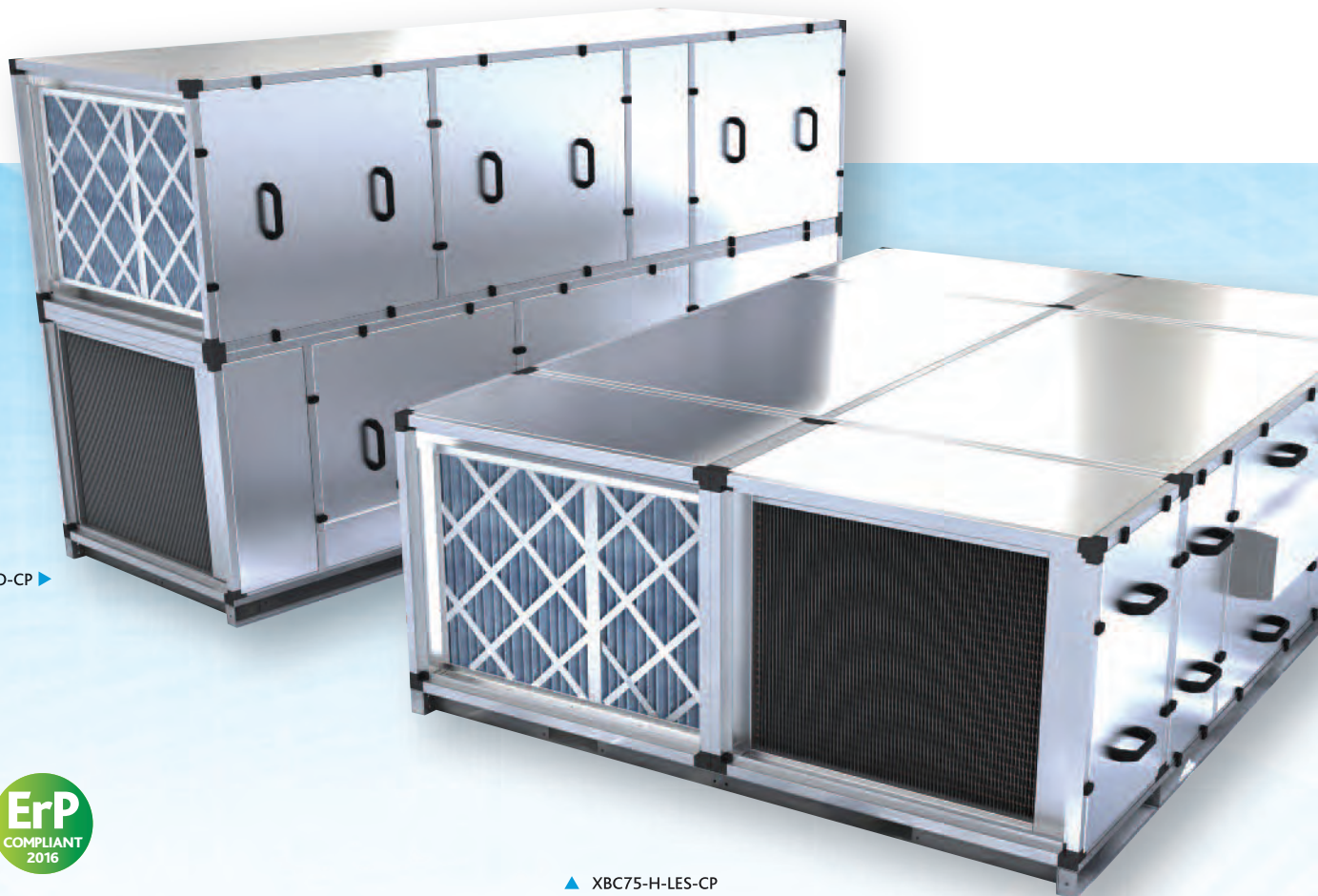

XBC85-V-LCO-CP ▶



▲ XBC75-H-LES-CP

LOWER NOISE & ENERGY CONSUMPTION

ACHIEVES BUILDING REGULATIONS

UNIQUE INTELLIGENT DESIGN PRACTICE

**NUAIRE XBC ECOSMART CONSTANT PRESSURE SYSTEMS ARE DESIGNED FOR CONTINUOUS VENTILATION** AND BECAUSE THEY FEATURE ECOSMART ON DEMAND CONTROL, COSTS ARE KEPT LOW.

When a room is occupied, a PIR or switch triggers the damper, which immediately operates as required, returning to background ventilation when the room is vacated.

The Constant Pressure Fan offers up to 70% savings over conventionally controlled central systems and should the primary fan or motor fail, the automatic change over guarantees uninterrupted ventilation because it works at reduced duty the unit consumes less power and is very quiet. This energy efficient ventilation solution is extremely cost effective to run and simple to install as all components are delivered assembled, wired and tested.

Specify Nuaire Ecosmart Constant Pressure and blow away your client's energy bills.

■ **MATCHED SILENCER OPTIONS** - Matched silencers double walled with acoustic infill provide the best acoustic solution. Internal and external silencers available.

■ **SAVES ENERGY** - Up to 70% saving over conventionally controlled central systems.  
- Not needlessly extracting conditioned air  
- Fan speed/motor power dictated by demand requirement.

■ **LESS POWER CONSUMPTION** - System works at reduced duty therefore consumes less power and is very quiet.

■ **TRUE DEMAND VENTILATION** - Only the areas that require ventilation receives ventilation.

■ **UNIQUE DIRECT ACTING MULTI-POSITION DAMPER NRG GRILLE** - Ensures operation only when room occupied with integrated PIR.

Note: XBC10-65 Constant Pressure works on extract fan only. XBC75-85 works with supply & extract.



### WHAT IS CONSTANT PRESSURE?

Constant Pressure Variable Volume systems (CPVV) are systems of fans, controls and sensors installed in a multi-room ducted system.

The system is intended to provide continuous background ventilation when the served spaces are unoccupied and will automatically increase the ventilation rate when any room is occupied to the design requirements.

Only the room requiring the increased ventilation will receive the ventilation.

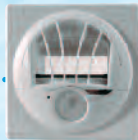

NRG Control Grille/Damper (optional).



Humidity Control (optional)



Inline CVD Damper (optional).

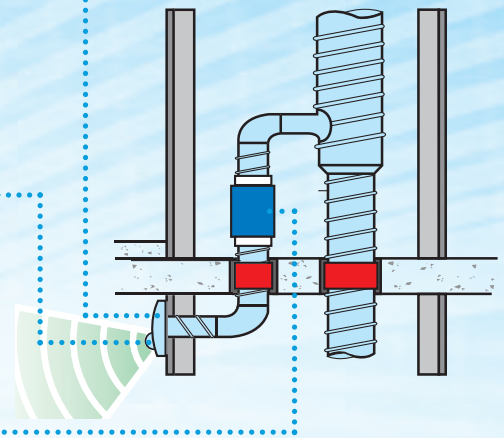

#### FLEXIBLE SOLUTION

■ **INTERNAL OR EXTERNAL APPLICATIONS** - XBC's options are available for ceiling applications, plant rooms and roof tops. Duty range to 1.5m<sup>3</sup>/s.

■ **ENERGY EFFICIENT CONTROLS** - Full Ecosmart control compatibility provides a simple 'plug & go' control solution with BMS interface and trickle and boost as standard.

■ **ECOSMART CONNECT CONTROL SYSTEM** - Allows stand-alone control and full BMS integration via BACnet (MS/TP). The system controller is augmented by application specific unit interface and diagnostic circuits. Controller software is pre-configured and the unit/control assembly is functionally tested at works (for further details of Ecosmart Control options refer to Ecosmart Controls Brochure). N.B Ecosmart Classic, Connect & Adapt have constant pressure options.

#### SAVES TIME & MONEY ON SITE

■ **PRE-WIRED** - All components assembled, wired and tested at the Nuair manufacturing facility.  
- Simply plug and go. No wiring required between fan and damper.

■ **DUCT MOUNTED CVD DAMPERS** - For unobtrusive flexibility.

■ **5 YEAR WARRANTY** - On Ecosmart Classic and Ecosmart Connect and Ecosmart Adapt Trend Constant Pressure models for peace of mind.

#### MAKES LIFE EASIER

(Model: XBC45-H-LCO-CP) ► External roof mounted heat recovery unit fitted with external weather roof. Typical applications include Schools, Hotels, Apartments & Offices.

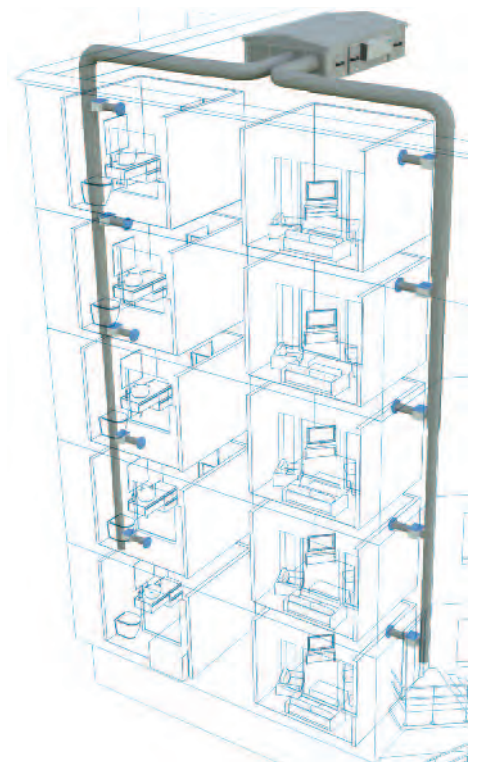

# CONSTANT PRESSURE HEAT RECOVERY

## PERFORMANCE & TECHNICAL INFORMATION



### HOW DOES CONSTANT PRESSURE WORK?

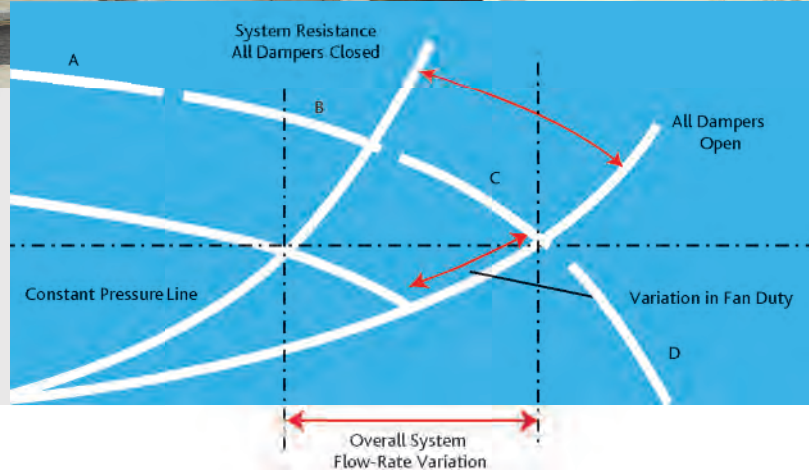

Independent extract grilles are installed at duct termination points in each of the spaces served, the grilles (for the benefit of this exercise we will consider our NRG grilles) are set to provide one of four boost ventilation rates. They are connected independently to a 230V AC supply via 230/12V transformers.

The grilles have in built occupancy sensors (PIR) and when the PIR detects movement the grille is driven open, when a grille opens the system pressure falls, the fan control detects the change and adjusts the motor speed to maintain the target pressure.

Grilles will stay open for approximately twenty minutes after the last movement has been seen and when it closes the control again compensates for the change in system pressure by adjusting fan speed.

By opening the grilles the pressure in the system will fall. The control system in the fan senses this and automatically speeds up to provide the higher volume and equalise the system pressure. This works in reverse with the grille closing, increasing the system pressure, automatically reducing the fan speed and again equalising the system pressure. Hence a constant pressure variable volume system. There is no inter-connection between grille/damper and fan.



### WHAT ARE NRG GRILLES?

A motorised two-position grille offered by to compliment the range of constant pressure fans. They have:

- A connecting spigot to suit 125mm duct opening.
- Four settable positions for boost vent rate, Positions 1, 2, 3 & 4 are indicated on the grille by the appropriate number of dots. The grille is pre-set at 5mm open to guarantee the trickle ventilation rate and the other positions are set via a trigger on the front of the grille.
- An integral occupancy sensor (PIR) which is not adjustable.
- They are 12V-AC operating and are supplied with 230/12V AC transformers for installation local to the grille. For ease of installation the transformer can be connected to an independent spur or ring main.
- Integrated run on timer providing approx. twenty minutes overrun, which is non-adjustable.
- Grille resistance is dependent upon the air volume passing through it, see the resistance charts.
- There is no interconnecting wiring between damper/grille & fan.

# CONSTANT PRESSURE HEAT RECOVERY PERFORMANCE & TECHNICAL INFORMATION

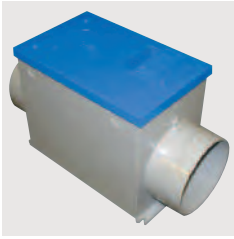

## CVD DAMPER

The CVD damper will work in the same way as the NRG but is mounted in-line and will be 230V operated responding to external switching devices such as humidistat, remote PIR, light switch, door switch etc. The in-line version has an in built motorised volume control damper to regulate the maximum flow

through the branch connection. It has an airflow sensor that continuously monitors the airflow and adjusts the damper position accordingly.

## THE INTEGRATED CONTROL PACKAGE

Is mounted in the fan chamber and consists of the XBC package including:

- The inverter, which is the mechanism that varies the speed of the motors
- A Ecosmart control printed circuit board which converts the data from the pressure transducer to an input signal to the inverter.
- Terminals to connect the incoming mains supply and remote status indicators.

## THE PRESSURE TRANSDUCER

Is precisely calibrated and mounted in the fan chamber and is connected to the Ecosmart control board. It continually monitors system pressure, compares the actual to the target allowing the control board to convert the data to an input signal to the inverter, thereby adjusting the motor speed to compensate for the system change.

## THE SET-UP BOX

Is mounted on the external face of the unit case, it is connected to the control pack by a low voltage lead and includes

- A potentiometer to set the target pressure.

All achieved whilst fan is running without re accessing the fan chamber.

## PERFORMANCE - CVD DAMPER

A nominal pressure drop must be allowed in order to ensure adequate airflow through the damper.

To ensure the airflow pattern through the damper produces consistent readings; the pressure drop across the damper should not exceed the recommended value. Recommended values are listed in the table below and shown in the performance envelope of each damper.

\*Recommended maximum operating pressure to ensure the damper would work within calibration limits. Keep the duct velocity as low as possible to ensure the system produces the lowest energy usage, preferably below 5m/s.

\*\*Allow 90Pa for duties below 100l/s and 150Pa for duties between 100l/s and 125l/s.

Code	Nominal Design Pressure Drop	Maximum Pressure Across Damper*
CVD100	60Pa	120Pa
CVD125	70Pa	140Pa
CVD150	80Pa	160Pa
CVD200	90Pa**	200Pa

## PERFORMANCE ENVELOPE FOR CVD100

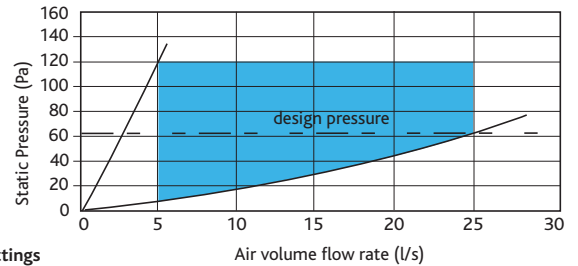

### CVD100 Settings

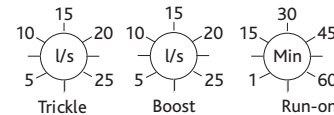

## PERFORMANCE ENVELOPE FOR CVD125

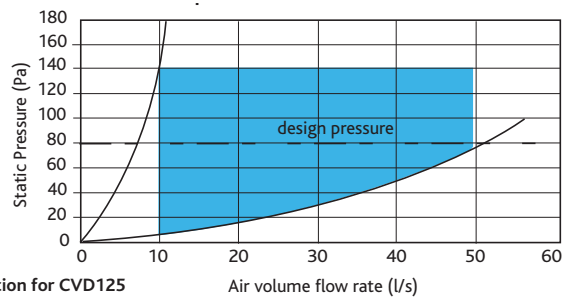

### Dial calibration for CVD125

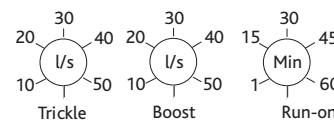

## PERFORMANCE ENVELOPE FOR CVD150

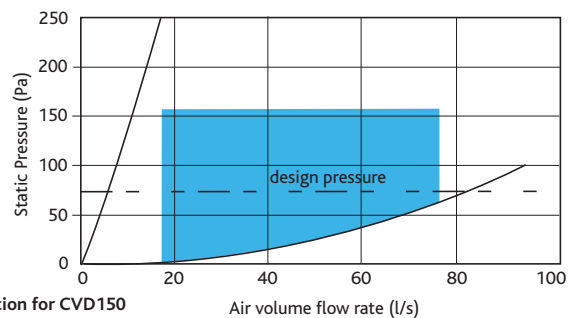

### Dial calibration for CVD150

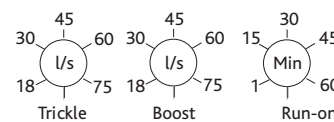

## PERFORMANCE ENVELOPE FOR CVD200

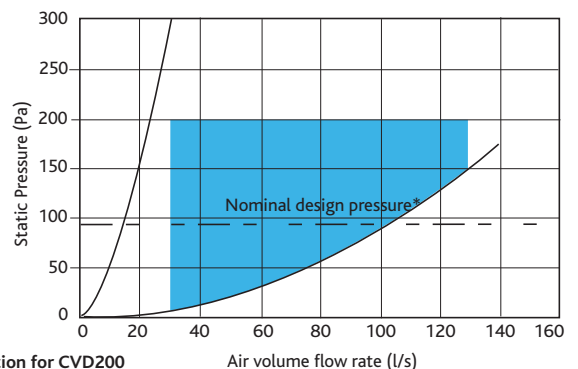

### Dial calibration for CVD200

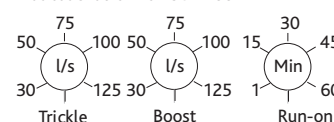

## WORKING WITH CUSTOMERS

**THE NUAIRE RANGES OF HEAT RECOVERY PRODUCTS HAVE DOMINATED THE HVAC MARKET FOR OVER 10 YEARS.** IN PARTICULAR NUAIRE HAS A LONG HISTORY OF DESIGNING VENTILATION PRODUCTS SPECIFICALLY FOR SCHOOLS AND UNIVERSITIES.

Nuaire boasts its own in-house Applications Engineering team which works in close partnership with its clients to ensure the best possible solution for their project and has even built a 30-seat mock classroom, incorporating the very latest ventilation technology, at its UK headquarters.

Designed to display and test its range of innovative school ventilation systems, the classroom is the only one of its kind among UK ventilation manufacturers.



Above: An underbench classroom unit. Project: (Trinity College).



Over the years it has become obvious that a standard 'one fan fits all' solution doesn't always meet the requirements of the project.

Whether there is a limitation of ceiling space or indeed no ceiling space and a bulkhead has to be built, Nuaire can work with its customers to provide the appropriate ventilation solution for their building type.



## WORKING WITH CUSTOMERS



Above: Project specific heat recovery unit. Project: (Liverpool schools).

### PROJECT: MANCHESTER SCHOOLS



**CLIENT: MANCHESTER CITY COUNCIL**

**CONSULTING PRACTICE:  
BCM MANCHESTER**

While ventilation systems typically sit within the ceiling void of a building, this project design requires the units to be completely exposed so Nuaire adapted the finish of the unit to a gloss white to enhance the lighting levels and coordinate with the interior design of the classroom.

Brian Morris, Managing Director of BCM, said:  
*"We have worked closely with Nuaire, following a competitive process, to design a solution which fits our strategy for achieving Manchester's challenging criteria.*

*They are compact, quiet and energy efficient and meet all the necessary building regulations."*

# THE COMPLETE HEAT RECOVERY SOLUTION

## Mechanical extract with heat recovery.

Heat recovery systems offer efficiency and control over the air quality and volume within the space. Providing tempered air into areas whilst extracting moisture laden air from 'wet' areas. Heat recovery is ideal for multi-storey accommodation.

## Heat Recovery with Constant Pressure.

Why ventilate empty rooms? Constant pressure is ideal for accommodation applications. A central extract system provides the necessary extraction, linked to all 'wet' areas such as bathrooms via a central fan, which is normally positioned on a roof and unique direct-acting multi position CVD dampers or NRG grilles ensures operation only when room is occupied.

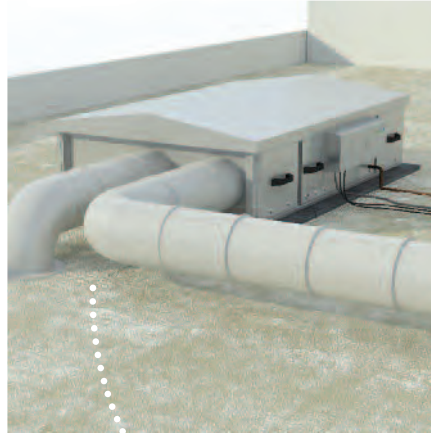

◀ (Model: XBOXER XBC45-H-NTWP).  
External roof mounted heat recovery unit fitted with external weather roof.



▲ (Model: MRXBOX95AB-WH2).  
Heat recovery unit mounted in a kitchen cupboard.

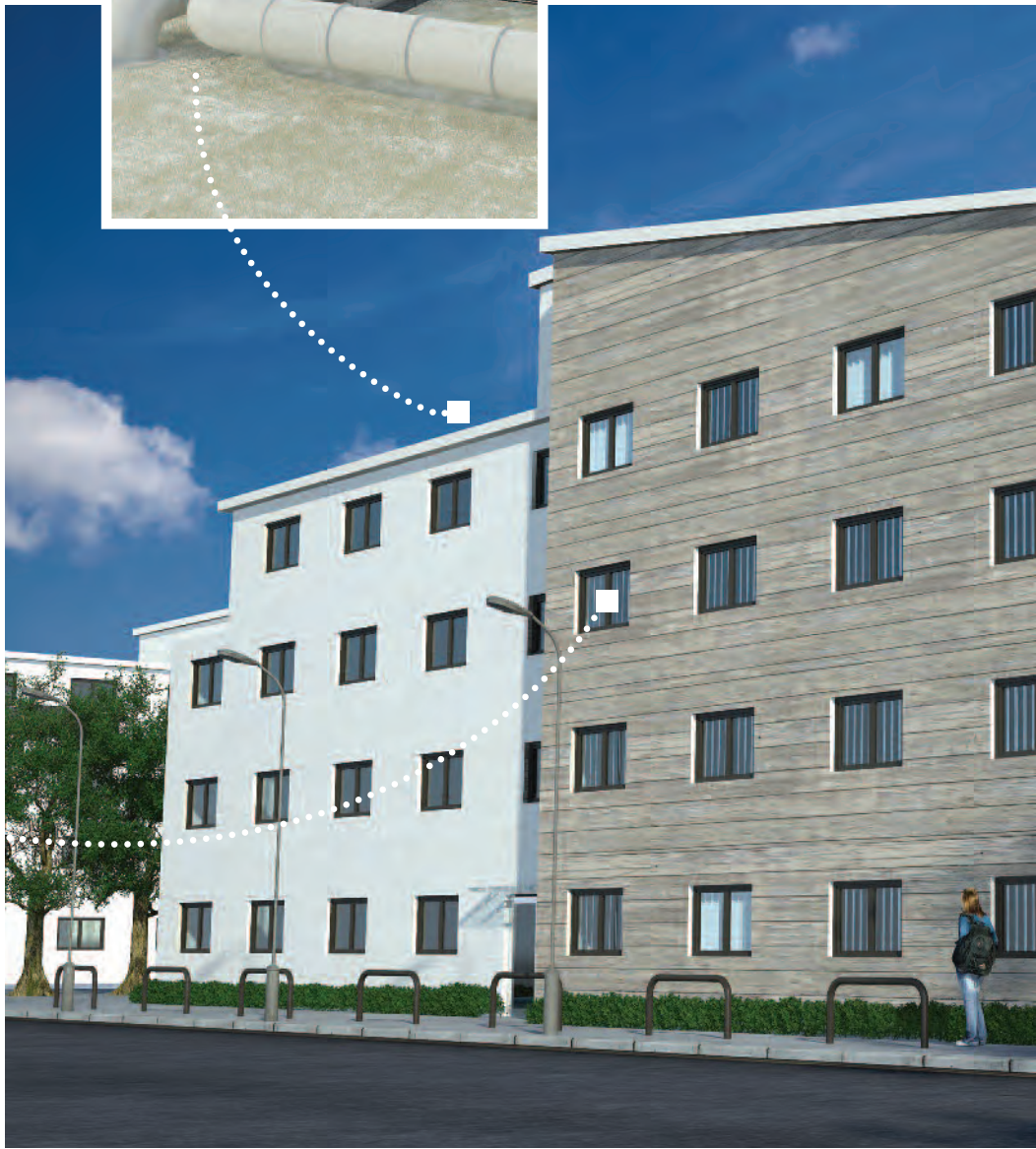

## ZONAL & CENTRALISED UNITS



**XBOXER XBC10-65**  
(up to 0.79m<sup>3</sup>/s)  
Market leading heat recovery units, up to 96% efficient.



**BOXER BESPOKE**  
(up to 20m<sup>3</sup>/s)  
Designed to meet project specific applications. Options include rotary wheels, plate heat exchangers & run around coils.



(Model: XBC85-V-LESWP) ▶

Externally mounted with weather roof.

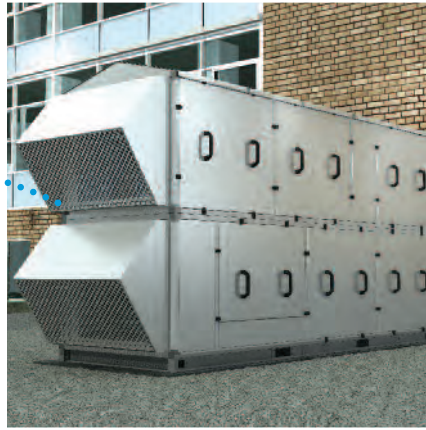

## LOCAL UNITS



**MRXBOX95AB-WM1**  
(up to 52l/s)

Compact heat recovery range for wall and cupboard mounting. Low voltage DC fans and motors.



**MRXBOX95AB-WM2**  
(up to 90l/s)

Compact heat recovery range for wall and cupboard applications. Can commission supply and extract fans independently.



**MRXBOX95AB-WH1**  
(up to 110l/s)

Compact heat recovery range for wall and cupboard applications. Can recover up to 95% of normally wasted heat.



**MRXBOX95AB-WH2**  
(up to 180l/s)

A high duty MVHR unit with low specific fan power (SFP). Low watt EC fans and high efficiency impellers for quiet running. For wall and cupboard applications.



**NEW XBOXER XBC75 & 85**  
(up to 1.5m<sup>3</sup>/s)

Vertical & horizontal heat recovery units, up to 96% efficiency.



**CONSTANT PRESSURE DAMPERS (CP)**

Energy efficient volume control damper for use with constant pressure fans. Wall (NRG) or duct (CVD) mounted.

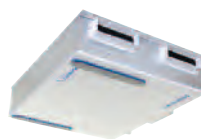

**MRXBOX95B-LP1E**

Low profile with a thermal efficiency of up to 80%. Ecosmart ready.





FOR MORE INFORMATION

[www.nuaire.co.uk](http://www.nuaire.co.uk)

COMMERCIAL

[www.nuaire.co.uk/commercial](http://www.nuaire.co.uk/commercial)

AIR HANDLING UNITS

[www.nuaire.co.uk/boxerahu](http://www.nuaire.co.uk/boxerahu)



**NUAIRE LIMITED**

Western Industrial Estate | Caerphilly | CF83 1NA

t +44 (0)29 2085 8200 | f +44 (0)29 2085 8222 | e [info@nuaire.co.uk](mailto:info@nuaire.co.uk)

[www.nuaire.co.uk](http://www.nuaire.co.uk)

As part of our policy of continuous product development Nuaire reserves the right to alter specifications without prior notice. Telephone calls may be recorded for quality and training purposes.

Part Number 671606 June 2016.

