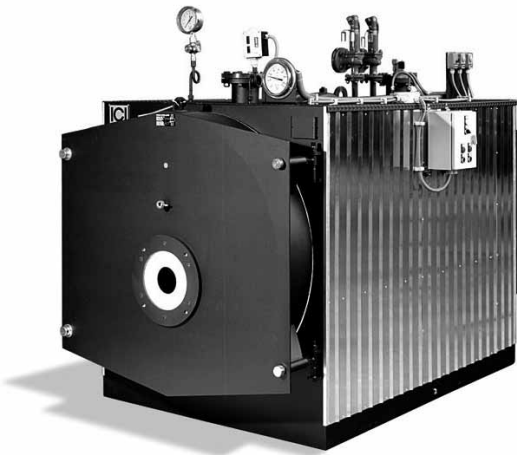

## INDUSTRIAL RANGE

HOT WATER

## ASX

## HOT WATER GENERATOR WITH REVERSE FLAME

*Nominal pressure 4.9 bar or 12 bar***Main features**

ASX hot water generator is monobloc with automatic operation, complete with all accessories needed for rapid commissioning. Manufactured with quality steel according to regulations in force and is welded with automatic submerged arc methods.

Some of the product's main features are related below:

- P265GH UNI EN 10028/2 and P275NH UNI EN 10028/3 quality steel boiler body welded and tested with methods approved and labeled CE in accordance with the PED 97 /23/EC directive
- horizontal wetback combustion chamber with reverse flame, supported and guided by a perforated stub to ensure full wet back design; has a curved surface beginning with ASX 2000 models
- flat tube plates with plasma drilled holes; front plate bent towards the combustion chamber, with head to head welding rather than angle throughout an angle, for models beginning with ASX 2000
- plate containment with flanged PN 16 or PN 40 EN 1092-1 connections for equipment operation; equipped with superior, inferior head hatch, lifting eye bolt.
- P235GH UNI EN 10216/2 smoke tubes welded to tube plates, equipped with helical turbulators
- single steel sheet front door, thermally insulated refractive materials with high aluminum content, mounted on adjustable hinges, easily opened by hand wheel bolts without the need to remove the burner; equipped with light indicator for combustion control
- steel sheet posterior smoke box can be removed using equipped bolts in order to clean the smoke pipes; provided with cleaning door and chimney connection
- support built from carbon steel sections able to support the entire unit.
- embossed metal sheet upper walkway for accessories service, parts located above the boiler
- high density, mineral wool mattress, adequate thickness thermal insulation, with embossed aluminum protective sheet mounted on a rectangular frame
- Supplied accessories needed for automatic operation with mechanical and hydraulic assembly for all equipment and certifications, also in compliance with the PED 97 /23/ EC Directive
- Electrical wiring converging to a single centralized control panel, having silicone insulated wires inserted in PVC protective sheaths all subjected to final functionality test

**Standard equipment:**

- pressure monitoring instrumentation unit, containing:
  - 2 safety valves
  - large dial 3 way test valve manometer
  - manual reset safety pressure gage
- temperature monitoring instrumentation unit, containing:
  - delivery large dial thermometer
  - delivery thermocouple connected to a framework thermo regulator
  - manual reset safety thermostat
- purging unit containing:
  - purge shut-off valve at flow start
  - male connection quick exhaust valve with manual lever
- boiler electric command panel, IP 55 electrical protection, composed of:
  - main switch
  - burner switch
  - electronic temperature regulator for two-stage burner control
  - high pressure light and alarm reset button
  - high temperature light and alarm reset button
  - alarm siren

Available accessories	Code
"TSS 72 HOT WATER" global security system HOT WATER	86900063

For each product always indicate the code at the time of the order.  
For higher pressures see our commercial department.

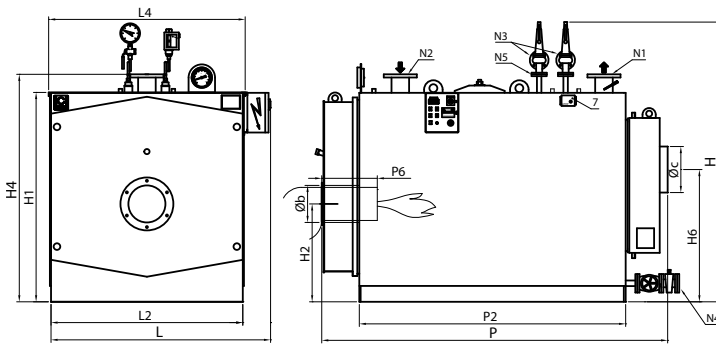

- Legend:**  
 N1 Flow  
 N2 Return  
 N3 Safety valve drain  
 N4 Boiler drain  
 N5 Safety valve connection

Characteristics	Code product	Design pressure	Nominal Power	Flow Thermal	100% efficiency (ref. C.O.P)	Fluid pressure drop	Total volume H <sub>2</sub> O	Fumes pressure drop	Fuel consumption			Total weight*
									Gas	Diesel fuel	Nafta	
Model		bar	kW	kW	%	mbar	lt	mbar	Nm <sup>3</sup> /h	kg/h	kg/h	kg
ASX 200	86180200	4,9	233	258	90,30	30	735	3,5	26,4	21,8	22,9	1400
ASX 300	86180300	4,9	349	387	90,20	29	750	3,5	39,6	32,6	34,3	1600
ASX 400	86180400	4,9	465	516	90,10	52	865	5	52,9	43,5	45,8	1700
ASX 500	86180500	4,9	581	645	90,10	33	1095	4,5	66,1	54,4	57,2	2200
ASX 600	86180600	4,9	698	774	90,20	48	1245	6	79,3	65,3	68,7	2200
ASX 800	86180800	4,9	930	1032	90,10	35	1535	5,5	105,7	87,1	91,5	2600
ASX 1000	86181000	4,9	1163	1292	90,00	54	1765	7	132,3	108,9	114,5	3000
ASX 1200	86181200	4,9	1395	1550	90,00	38	2265	8	158,7	130,7	137,4	3400
ASX 1500	86181500	4,9	1744	1959	90,00	59	2830	6,5	198,3	163,3	171,8	5000
ASX 1750	86181750	4,9	2035	2260	90,00	80	3135	7,5	231,4	190,6	200,4	6000
ASX 2000	86182000	4,9	2326	2584	90,00	105	3560	8	264,5	217,8	229,1	7300
ASX 2500	86182500	4,9	2907	3229	90,00	52	4360	9	330,6	272,3	286,3	9000
ASX 3000	86183000	4,9	3488	3876	90,00	75	5170	9,5	396,8	326,8	343,6	10000

Dimensions	H	H1	H2	H4	H6	L	L2	L4	P	P2	P6	Øb	Øc	N1/N2	N1	N2	N3	N4	N5
Model	mm	mm	mm	mm	mm	mm	mm	mm	mm	mm	mm	mm	mm	PN	DN/in	DN/in	DN/in	DN/in	DN/in
ASX 200	1730	1240	575	1360	720	1290	1080	1170	2100	1510	280-330	180	250	16	65	65	40	32	25
ASX 300	1780	1290	620	1410	850	1380	1170	1260	2100	1510	310-360	225	250	16	80	80	40	32	25
ASX 400	1780	1290	620	1410	850	1380	1170	1260	2300	1760	310-360	225	250	16	80	80	40	32	25
ASX 500	1940	1450	700	1570	950	1530	1320	1410	2300	1760	350-400	280	300	16	100	100	40	32	25
ASX 600	1940	1450	700	1570	950	1530	1320	1410	2550	2010	350-400	280	300	16	100	100	40	32	25
ASX 800	2090	1580	740	1720	1000	1660	1450	1540	2600	2010	370-420	280	350	16	125	125	40	32	25
ASX 1000	2090	1580	740	1720	1000	1660	1450	1540	2900	2310	370-420	280	350	16	125	125	40	32	25
ASX 1200	2190	1690	765	1820	1200	1750	1540	1630	3165	2502	370-420	320	400	16	150	150	40	32	25
ASX 1500	2445	1870	850	2000	1200	1930	1720	1810	3417	2714	420-470	360	450	16	150	150	50	32	32
ASX 1750	2445	1870	850	2000	1200	1930	1720	1810	3717	3012	420-470	360	450	16	150	150	50	32	32
ASX 2000	2455	1890	880	2010	1380	1950	1740	1830	3719	3016	480-530	360	500	16	150	150	50	40	32
ASX 2500	2595	2100	950	2230	1400	2160	1900	2040	4237	3514	480-530	360	550	16	200	200	50	65	40
ASX 3000	2765	2100	970	2250	1500	2160	1950	2040	4525	3754	480-530	400	600	16	200	200	65	40	40

Characteristics	Code product	Design pressure	Min-max work pressure
Model		bar	bar
ASX 200 - 12 bar	86190200	12	8 - 11,5
ASX 300 - 12 bar	86190300	12	8 - 11,5
ASX 400 - 12 bar	86190400	12	8 - 11,5
ASX 500 - 12 bar	86190500	12	8 - 11,5
ASX 600 - 12 bar	86190600	12	8 - 11,5
ASX 800 - 12 bar	86190800	12	8 - 11,5
ASX 1000 - 12 bar	86191000	12	8 - 11,5
ASX 1200 - 12 bar	86191200	12	8 - 11,5
ASX 1500 - 12 bar	86191500	12	8 - 11,5
ASX 1750 - 12 bar	86191750	12	8 - 11,5
ASX 2000 - 12 bar	86192000	12	8 - 11,5
ASX 2500 - 12 bar	86192500	12	8 - 11,5
ASX 3000 - 12 bar	86193000	12	8 - 11,5

Data regarding Nominal pressure 4.9 bar