

High-head thermal ventilating units with BLDC motor

UTN i 4 - 10 kW



Brushless motor



Ducted



2-pipe system



4-pipe system



Centrifugal fan



ERGO Supervision

High efficiency and low noise emissions for ducted applications

The thermal ventilating units of the UTNi range with inverter motors and cooling capacities of 4 to 10 kW represent an evolution of the UTN series: keeping in pace with current legislation on energy savings and equipment efficiency and the most recent technological developments in the realm of electric motors, Galletti offers ducted units equipped with inverter-controlled permanent magnet BLDC motors. This solution makes it possible to reduce electricity consumption by up to 70% compared to a traditional asynchronous motor and at the same time offers the possibility of achieving a precise regulation of air flow, thanks to its ability to vary the number of fan revolutions in a continuous and efficient manner. The particular features which characterize the UTN series, namely, the height of 280 mm to enable the units to be accommodated in false ceilings, flexibility of installation and connection to air ducts and wide selection of accessories, are maintained to ensure the same standards of quality. Moreover, the availability of heat exchangers with a large number of rows makes it possible to use a low-temperature thermal carrier fluid in the heating mode, which means further energy savings.

PLUS

- ✓ Permanent magnet BLDC motor
- ✓ Low electricity consumption
- ✓ Easy setup of ventilation section
- ✓ Reduced height across the entire range (280 mm)
- ✓ Vertical and horizontal installation
- ✓ Vast range of available accessories
- ✓ High flexibility of installation

AVAILABLE VERSIONS

UTN i

Thermal ventilating unit suitable for 2-pipe systems

UTN i DF

Thermal ventilating unit suitable for 4-pipe systems (2 heat exchangers)

UTN i DP

The version with double panelling is made with pre-painted sheet steel insulated with class 0 fire-resistant rockwool.

Comfort and quiet operation

Thanks to the possibility of regulating the rotation speed of the motor with high precision, UTN i is well-suited to interiors where keeping noise levels low is a must.





MAIN COMPONENTS

Structure

Made of galvanized sheet steel insulated with sound-deadening, heat-insulating, self-extinguishing closed-cell material to reduce noise emissions and prevent the formation of condensate on the outside surface.

Heat exchanger

It is composed of copper tubing and aluminium fins fixed by expansion. The water connections are reversible. An additional exchanger is available for installing the unit in 4-pipe systems.

Fan

The aluminium fans are of the centrifugal type, with double suction and staggered blades to reduce noise emissions. They are statically and dynamically balanced to minimize the stresses transmitted to the motor shaft.



BLDC electric motor

Permanent magnet motor. The unit is equipped with an inverter board to control the motor, that makes it possible to precisely set the maximum rotation speed (control signal 0-10 V).

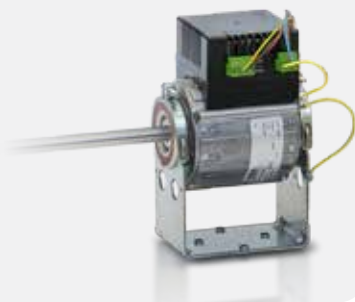

Condensate collection and drainage system

It consists of two insulated galvanized sheet steel trays designed for horizontal and vertical installation.

Filter module

The air filter, made of regenerable acrylic fibre, is available as an accessory in filtration classes G2 or G4.

ACCESSORIES

CONTROL PANELS AND THERMOSTATS

MCLE	MYCOMFORT LARGE
EVO	Wall-mounted microprocessor controller
MCSWE	Water/air sensor for MYCOMFORT BASE, MYCOMFORT MEDIUM, MYCOMFORT LARGE and LED503 microprocessor controllers.

AIR INTAKE MODULES WITH FILTER

MAF	Air intake module with G2 flat filter
MAFO	Air intake module with G4 undulated filter

AIR INTAKE AND OUTLET JUNCTION PANELS

PCOC	Junction panel with rectangular duct
PCOF	Junction panel with flexible circular duct Ø 200
G90	90° elbow outlet and inlet connector

MOTOR-DRIVEN VALVES AND DRIP TRAYS

V	3-way motor-driven valve
M	ON/OFF and modulating motors, modulating motors for motor driven valves V
R	Hydraulic connector kit for installation of valve
VRCV	Water drip tray for vertical installation UTN
VRCH	Water drip tray for horizontal installation UTN
KSC1	Condensate drainage pump

HOT WATER POST-HEATING COILS

BP	Post-heating kit with hot water coil
-----------	--------------------------------------

ELECTRICAL HEATING ELEMENTS

RE	Heating elements, safety devices, power relay box
-----------	---

MOTOR DRIVEN EXTERNAL AIR INTAKE LOUVER

PA90	Motor-driven external air intake louver
-------------	---

VIBRATION-DAMPING COUPLINGS

GA	PVC vibration-damping coupling
GAT	Heat-resistant silicone-coated cloth vibration-damping coupling

HOSES - PLUGS

TFA	Uninsulated hose Ø 200 mm
TFM	Insulated hose Ø 200 mm
TP	Plastic plug Ø 200 mm

AIR INTAKE AND OUTLET DUCTS

CA	Air intake duct with honeycomb grille
CAF	Air intake duct with honeycomb grille and G2 filter
CM	Insulated air outlet duct, with 2-way grille

AIR OUTLET AND INTAKE GRILLES

GM	Aluminium air outlet grille, with subframe
GR	Aluminium air intake grille, with subframe

Rated technical data

UTN i		0 8			08A			12			12A		
Fan speed		min	med	min	min	med	min	min	med	min	min	med	min
Control voltage	V	6,0	7,4	8,9	6,0	7,4	8,9	7,3	8,0	8,8	7,3	8,0	8,8
Air flow (E)	m³/h	534	700	802	531	692	792	1,021	1134	1241	998	1107	1206
Available static pressure (E)	Pa	29	50	65	30	50	65	41	50	59	41	50	59
Power input (E)	W	40	73	112	40	73	112	102	125	152	102	125	152
Total cooling capacity (1) (E)	kW	2,87	3,54	3,91	3,42	4,27	4,76	5,33	5,77	6,17	5,87	6,37	6,81
Sensible cooling capacity (1) (E)	kW	2,23	2,77	3,09	2,58	3,26	3,68	3,99	4,32	4,63	4,45	4,85	5,21
Water flow (1)	l/h	493	607	671	587	732	817	915	990	1059	1008	1093	1169
Water pressure drop (1) (E)	kPa	10	14	17	8	12	14	18	21	24	15	17	19
Heating capacity (2) (E)	kW	3,63	4,41	4,85	4,24	5,22	5,79	6,68	7,20	7,67	7,49	8,11	8,65
Water pressure drop (2) (E)	kPa	8	12	14	7	10	12	15	17	19	12	14	15
Additional coil heating capacity DF (3) (E)	kW	3,70	4,21	4,48	3,69	4,18	4,45	5,98	6,28	6,53	5,93	6,21	6,44
Water flow (3)	l/h	324	369	393	324	367	391	525	551	573	521	545	566
Water pressure drop (3) (E)	kPa	6	8	9	6	8	9	14	16	17	12	13	14
Standard coil - number of rows	n°	3			4			3			4		
Additional coil DF - number of rows	n°	1			1			1			1		
Total sound power level (4)	dB(A)	54	61	66	54	61	66	59	63	69	61	63	69
Inlet + radiated sound power level (4) (E)	dB(A)	52	59	64	52	59	64	56	60	66	56	60	66
Outlet sound power level (4) (E)	dB(A)	51	58	63	51	58	63	55	59	65	59	59	65

UTN i		16			16 A		
Fan speed		min	med	min	min	med	min
Control voltage	V	6,7	7,7	8,9	6,7	7,7	8,9
Air flow (E)	m³/h	1208	1384	1609	1200	1371	1584
Available static pressure (E)	Pa	38	50	67	38	50	66
Power input (E)	W	124	170	248	124	170	248
Total cooling capacity (1) (E)	kW	6,32	7,01	7,83	6,97	7,79	8,75
Sensible cooling capacity (1) (E)	kW	5,14	5,77	6,55	5,53	6,24	7,10
Water flow (1)	l/h	1085	1202	1344	1197	1336	1501
Water pressure drop (1) (E)	kPa	17	20	24	11	13	16
Heating capacity (2) (E)	kW	7,74	8,52	9,46	8,70	9,62	10,7
Water pressure drop (2) (E)	kPa	13	16	20	9	10	13
Additional coil heating capacity DF (3) (E)	kW	8,01	8,53	9,13	7,98	8,50	9,07
Water flow (3)	l/h	703	749	801	701	746	796
Water pressure drop (3) (E)	kPa	10	11	13	24	27	30
Standard coil - number of rows	n°	3			4		
Additional coil DF - number of rows	n°	1			1		
Total sound power level (4)	dB(A)	62	67	72	62	67	72
Inlet + radiated sound power level (4) (E)	dB(A)	60	64	70	60	64	70
Outlet sound power level (4) (E)	dB(A)	58	63	69	58	63	69

- (1) Water temperature 7 / 12°C, air temperature D.B. 27°C, W.B. 19°C (47% relative humidity)
 (2) Inlet water temperature 50°C, water flow rate same as in cooling mode, air temperature 20°C
 (3) Water temperature 70 / 60°C, air temperature 20°C
 (4) Sound power measured according to standards ISO 3741 and ISO 3742
 (E) EUROVENT certified data
 Power supply 230-1-50 (V-ph-Hz)



Dimensional drawings

UTN i

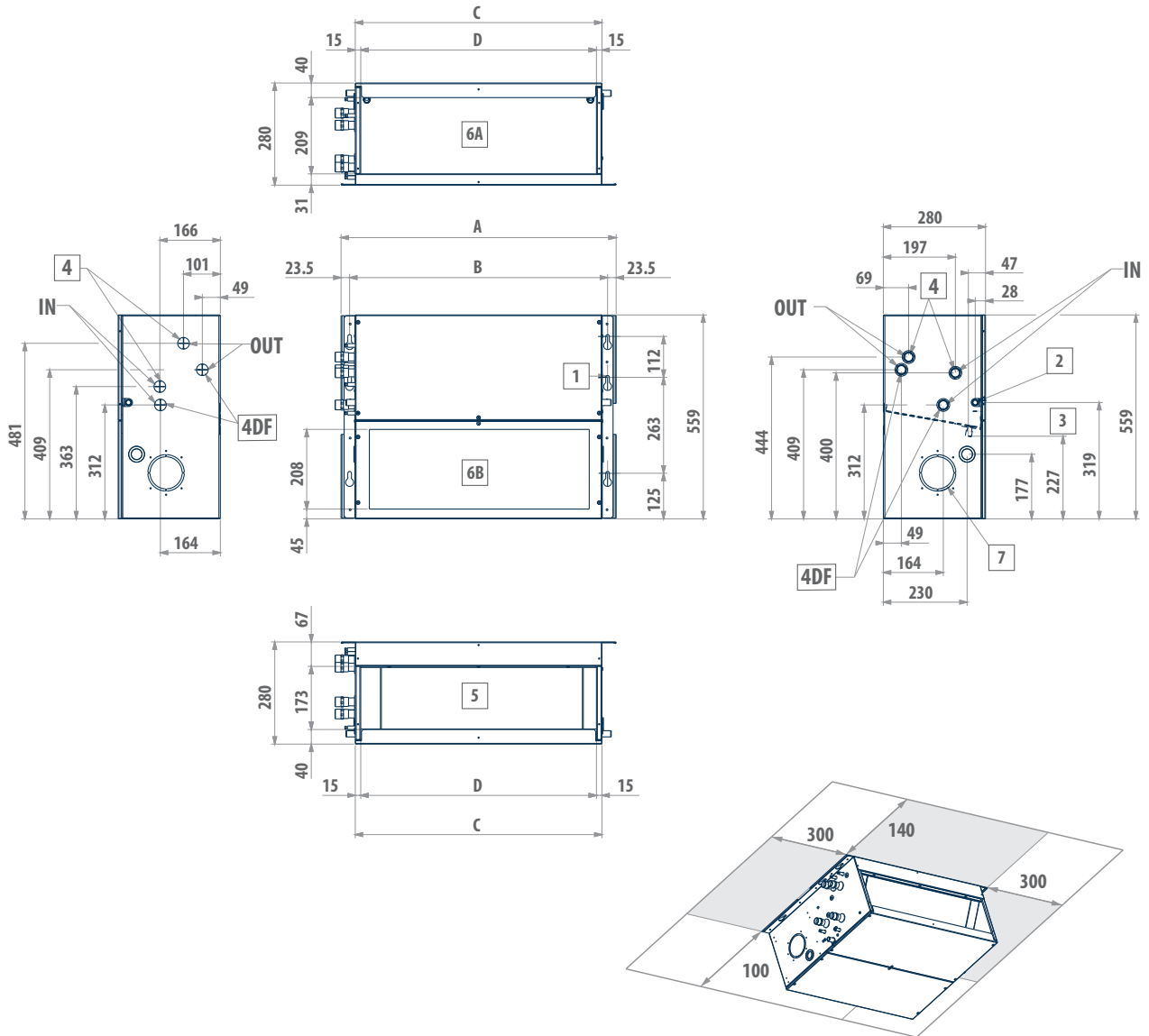

LEGEND

1	Nr.6 quick-coupling slots
2	Drain outlet for horizontal installation
3	Drain outlet for vertical installation
4	Water connections on the right
4DF	Additional heat exchanger water connections
5	Air outlet
	Air intake
6	6-A supply condition
	6-B modifiable during installation
7	Circular pre-cut slot (Ø 100 mm) for intake of external air

UTN i	A	B	C	D	2	3	4	4DF
06 - 06A	754	707	676	646	17	17	3/4"	3/4"
08 - 08A	754	707	676	646	17	17	3/4"	3/4"
12 - 12A	964	917	886	856	17	17	3/4"	3/4"
16 - 16A	1174	1127	1096	1066	17	17	3/4"	3/4"