

C 340/640-...

FLOOR STANDING GAS CONDENSING BOILERS



C 340-...



C 640-...

• C 340-280 to 650

from 56 to 651 kW, gas condensing boilers simple body, for hot water central heating and DHW production with independent calorifier

• C 640-560 to 1300

from 74 to 1303 kW, gas condensing boilers double body, for hot water central heating and DHW production with independent calorifier



Heating and DHW production with independent calorifier



All natural gases



Condensing

OPERATING CONDITIONS

Max. operating temperature: 90°C
 Safety thermostat: 110°C
 Max. operating pressure: 7 bar
 Min. operating pressure: 0.8 bar
 Power supply: 230 V/50 Hz

Homologation

B23 - B23P - C33 - C53 - C63 - C93

gas category

II₂ES_i
 NO_x classification: 6

All of these boilers are fitted as standard with a DIEMATIC Evolution control panel.

The DIEMATIC Evolution and options, enable: control of complex installations, integration into existing systems, control and regulation of a domestic hot water circuit as well as a circuit with a mixing valve. For larger installations, it is possible to connect 2 to 8 boilers of type C 340-... or 4 boilers of type C 640-... in a cascade configuration

Various air/flue gas connection configurations are possible. We offer two types of solution: by vertical forced flue or to a chimney.

C 340-... ECO and C 640-... ECO boilers are floor-standing gas condensing boilers, delivered assembled and tested in the factory.

HIGH PERFORMANCE

- Annual operating efficiency up to > 109%,
- Low pollutant emissions:
 - NOx < 50 mg/kWh
 - NOx classification: 6 according to EN 656 (type B)/prEN 15420 (type C)
- Low noise level and electricity consumption thanks to the modulating fan:
 - Mean noise level of 62 to 68 dB[A] at a distance of 1 m from the boiler,
 - 10 to 536 W (C 640-1 150l) maximum depending on the output.

PARTICULARITY OF C 640-...

They consist of 2 x C 340-... boilers with the same power, each having a control panel Diematic Evolution and assembled with a flue gas collector.

A flue gas valve integrated in the combustion line prevents any interference of the discharge of the flue gases from the line's 2 generators, thus facilitating cascade installation.

STRONG POINTS

- Exchanger in cast aluminium/silicium sections, highly resistant to corrosion, with self-cleaning properties linked to the flow of condensates, requiring no minimum water flow thanks to burner modulation algorithm, which manages the transitory phases in the installation which are responsible for very low or even zero flow rates in the boiler.
- Cylindrical total premix gas burner with metallic fibre coating, modulating from 20 to 100% for C 340-... and from 15 to 100% for C 640-...:
 - Perfect adaptation of boiler output to the actual needs of the installation,
 - Optimum combustion quality over the entire power range by maintaining a constant air/gas ratio through the venturi system
- Electronic ignition
- Ionisation sensor
- DIEMATIC Evolution control for which the control system is open to all installation configurations, including the most complex: cascade operation possible for 2 to 8 type C 340-... boilers or 4 type C 640-... boilers.
- Numerous control panel and connection configuration options, which enable the management of external safety devices, modulating pumps, systems combined with solar energy or heat pumps and the programmed control of heating circuits with mixing valves.
- It is designed to communicate with DIEMATIC VM Evolution control systems and with remote control systems compatible with the ModBus protocol
- Optional return separation possible (2nd return to be dually controlled for C 640-...) for maximum exploitation of condensation
- Easy installation
 - Boiler positioning is particularly easy thanks to the castor + rail guidance system, which can be used to slide the boiler from its pallet and move it to its final position,
 - Can be dismantled down to the boiler body on the frame with its castors, to access awkward locations
- Compactness: 1,53 m² floor space and 568 kg for 651 kW
- Boiler assembled and tested in the factory
- Easy maintenance
 - Self-cleaning condensing boiler body
 - Rapid burner access via removable covers
 - Rapid exchanger access via the inspection hatch.

MODELS AVAILABLE

C 340 BOILERS

BOILER

PROJECT



For heating, DHW production with independent calorifier. C 340-... boilers are available in 2 versions for hydraulic connection to the left or right, with DIEMATIC Evolution control panel.

CONTROL PANEL
DIEMATIC EVOLUTION



MODEL
WITH HYDRAULIC CONNECTION
TO THE RIGHT TO THE LEFT

USEFUL
OUTPUT RANGE
AT 50/30°C
(KW)

C 340-280 VD DIEMATIC Evolution	C 340-280 VG DIEMATIC Evolution	56 to 279
C 340-350 VD DIEMATIC Evolution	C 340-350 VG DIEMATIC Evolution	71 to 350
C 340-430 VD DIEMATIC Evolution	C 340-430 VG DIEMATIC Evolution	84 to 425
C 340-500 VD DIEMATIC Evolution	C 340-500 VG DIEMATIC Evolution	98 to 497
C 340-570 VD DIEMATIC Evolution	C 340-570 VG DIEMATIC Evolution	113 to 574
C 340-650 VD DIEMATIC Evolution	C 340-650 VG DIEMATIC Evolution	127 to 651

C 640 BOILERS

BOILER

PROJECT



For heating, DHW production with independent calorifier.

SPECIAL PROPERTIES:
Composed of 2 boilers type C 340-... wired in cascade, with 2 DIEMATIC Evolution control panels.

CONTROL PANEL
DIEMATIC EVOLUTION



MODEL
WITH HYDRAULIC CONNECTION
TO THE RIGHT OR TO THE LEFT

USEFUL
OUTPUT RANGE
AT 50/30°C
(KW)

C 640-560 DIEMATIC Evolution	74 to 558
C 640-700 DIEMATIC Evolution	94 to 700
C 640-860 DIEMATIC Evolution	131 to 850
C 640-1 000 DIEMATIC Evolution	130 to 994
C 640-1 140 DIEMATIC Evolution	156 to 1 148
C 640-1 300 DIEMATIC Evolution	165 to 1 303

TECHNICAL SPECIFICATIONS

FROM THE BOILERS

MAIN DIMENSIONS (IN MM AND INCHES)

C 340-... (LEFT VERSION)

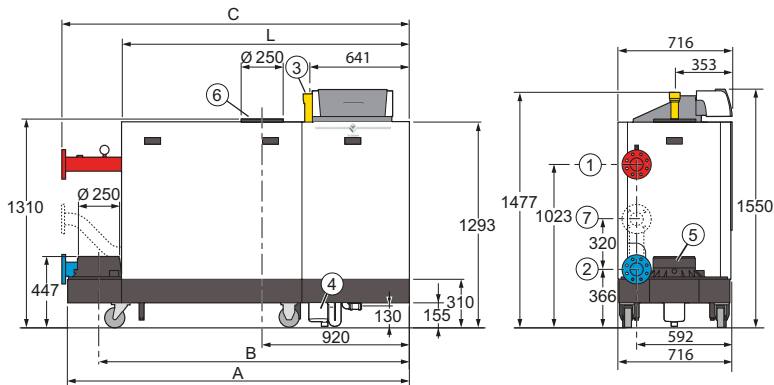

C 340-... (RIGHT VERSION)

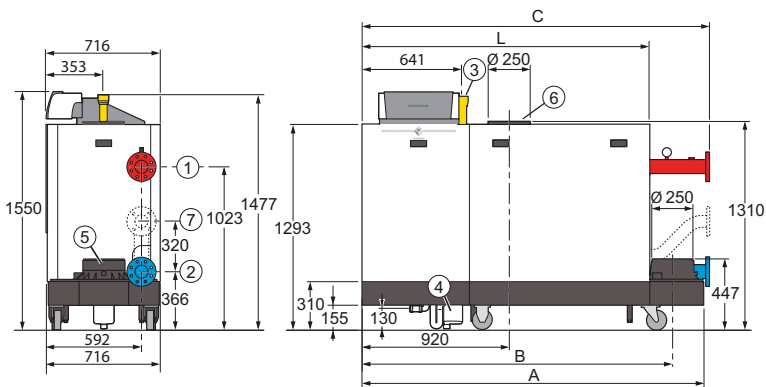

	A	B	C	L
C 340-280	1 833	1 635	1 862	1 490
C 340-350	1 833	1 635	1 862	1 490
C 340-430	1 833	1 635	1 862	1 490
C 340-500	2 142	1 944	2 172	1 800
C 340-570	2 142	1 944	2 172	1 800
C 340-650	2 142	1 944	2 172	1 800

LEGEND

- ① Heating flow: nozzle DN 80 (according to DIN 2576)
- ② Return flow: nozzle DN 80 (according to DIN 2576)
- ③ Gas inlet G 2" (tapped connection)
- ④ Condensates run-off, siphon provided, for PVC tube Ø 32 mm (inlet)
- ⑤ Flue gas nozzle Ø 250 mm
- ⑥ Combustive air inlet Ø 250 mm
- ⑦ Second return nozzle (optional) DN 65 according to DIN 2576

C 640-...

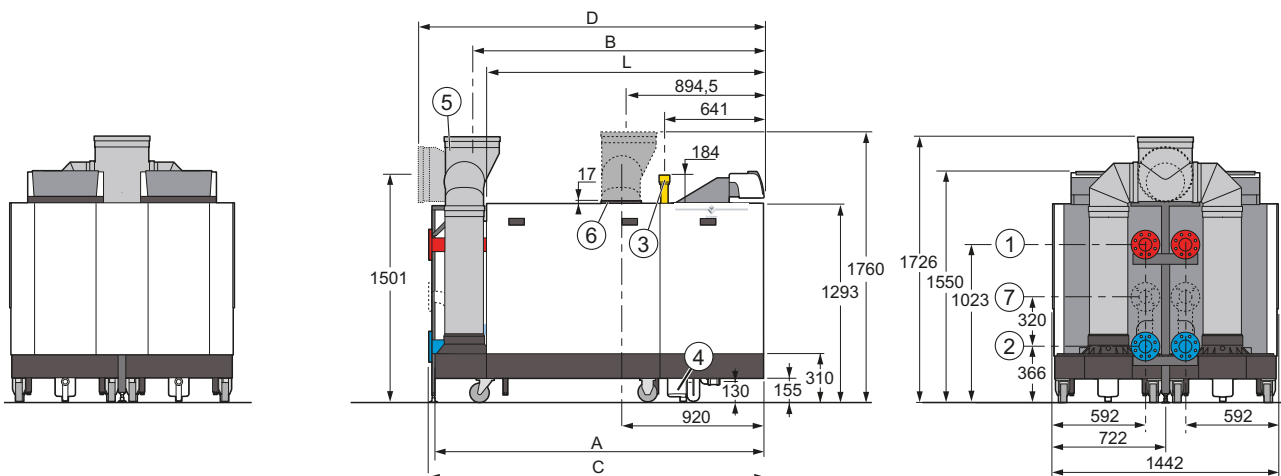

	A	B	C	D	L
C 640-560	1 833	1 582	1 862	1 962	1 490
C 640-700	1 833	1 582	1 862	1 962	1 490
C 640-860	1 833	1 582	1 862	1 962	1 490
C 640-1 000	2 142	1 892	2 172	2 271	1 800
C 640-1 140	2 142	1 892	2 172	2 271	1 800
C 640-1300	2 142	1 892	2 172	2 271	1 800

LEGEND

- ① Heating flow: nozzle DN 80 (according to DIN 2576)
- ② Return flow: nozzle DN 80 (according to DIN 2576)
- ③ Gas inlet G 2" (tapped connection)
- ④ Condensates run-off, siphon provided, for PVC tube Ø 32 mm (inlet)
- ⑤ Flue gas nozzle Ø 350 mm
- ⑥ Combustive air inlet Ø 250 mm (air inlet collector for option Ø 350 mm)
- ⑦ Second return nozzle (optional) DN 65 according to DIN 2576

NOTE

The control panels on the C 340/640-... can be mounted in front position or laterally; see instruction delivered with the boiler.

TECHNICAL SPECIFICATIONS

OF THE BOILERS

TECHNICAL SPECIFICATIONS AND PERFORMANCES

Generator type: heating only

Boiler type: condensing

Burner:

- modulating burner with total pre-mixing

Energy used: natural gas

Combustion evacuation:

- chimney or sealed

NOx classification: 6

"CE certificate" ref: 0063CU3937

Average operating temperature:

- Max_operat. T: 90°C
- Min_operat. T: 25°C

BOILER SPECIFICATIONS

MODELS		C 340-...					C 640-...							
		280	350	430	500	570	650	560	700	860	1000	1140	1300	
Useful nominal output at Q _{nom}	kW	260.7	326.7	394.8	461.0	530.4	600.9	521.4	653.3	789.5	922.1	1060.8	1201.7	
Max. nominal useful output at 50/30°C (P _n)	kW	278.8	350.3	424.5	497.1	573.5	651.5	557.5	700.6	849	994.3	1147	1303	
Efficiency in% P _{ci} , at load...% P _n and temp... °C	• 100 % P _n , at average temp. 70°C	%	98.0	98.1	98.2	98.3	98.4	98.5	98.0	98.1	98.2	98.3	98.4	98.5
	• 100 % P _n , at return temp. 30°C	%	104.8	105.2	105.6	106.0	106.4	106.8	104.8	105.2	105.6	106.0	106.4	106.8
	• 30 % P _n , at return temp. 30°C	%	109.2	109.0	108.8	108.6	108.3	108.1	109.2	109.0	108.8	108.6	108.3	108.1
Useful efficiency at ...% of rated heat output	• 100 % Eta 4	%	88.3	88.4	88.5	
	• 30 % Eta 1	%	98.4	98.2	98.0	
Nominal water flow rate at Δt = 20 K at 80/60°C	m ³ /h	11.1	13.9	16.8	19.6	22.5	25.5	22.2	27.8	33.6	39.2	45.1	51.0	
Stand-by losses at Δt = 30 K	W	464	479	493	508	522	537	928	958	986	1016	1044	1074	
Auxiliary electrical power at P _n boiler	W	280	345	450	576	768	720	560	690	900	1152	1536	1440	
Electrical power at minimum output boiler	W	60	62	76	86	89	80	120	124	152	172	178	148	
Electrical power in stand-by	W	10	9	10	10	10	10	20	18	20	20	20	20	
Min nominal Output at 50/30°C	W	56/278.8	71/350.3	84/424.5	98/497.1	113/573.5	127/651.5	56/557.5	71/700.6	84/849	98/994.3	113/1147	127/1303	
Nominal output mini/maxi at 80/60°C	kW	51.1/260.7	64.8/326.7	78.6/394.8	91.5/461	105.5/530.4	118.7/600.9	75.8/521.4	86.7/653.3	122.6/789.5	122.3/922.1	148.1/1060.8	165.4/1201.7	
Pressure drop at Δt = 20 K	mbar	113	110	120	110	125	130	113	110	120	110	125	130	
Gas flow rate max. (15°C - 1013 mbar)	• natural gas H	m ³ /h	28.1	35.2	42.5	49.6	57	64.6	56.3	70.5	85.1	99.3	115.8	129.1
	• natural gas L	m ³ /h	32.7	41	49.5	57.7	66.3	75.1	65.5	82	99	115.4	134.7	150.2
Mass flue gas flow rate min.	kg/h	91	115	138	160	184	205	135	153	216	214	258	286	
Mass flue gas flow rate max.	kg/h	448	561	677	790	907	1 027	896	1 121	1 354	1 579	1 842	2 054	
Max./Min. flue gas temperature	°C	30/60	30/61	30/64	30/63	30/66	30/65	30/60	30/61	30/64	30/63	30/66	30/65	
Max. hydraulic flow rate	m ³ /h	20.4	25.6	30.9	36.1	41.5	47.0	40.8	51.2	61.8	72.2	83.1	94.1	
Flue gas pressure available at the nozzle	Pa	130	120	130	150	150	150	130	120	130	150	150	150	
Water content	l	49	60	71	82	93	104	98	120	142	164	186	208	
Floor area	m ²	1.32	1.32	1.32	1.54	1.54	1.54	2.83	2.69	2.69	3.13	3.13	3.13	
Net weight	kg	366	400	435	497	533	570	711	775	841	961	1029	1099	

TECHNICAL SPECIFICATIONS

OF THE BOILERS

DESCRIPTION

C 340-...

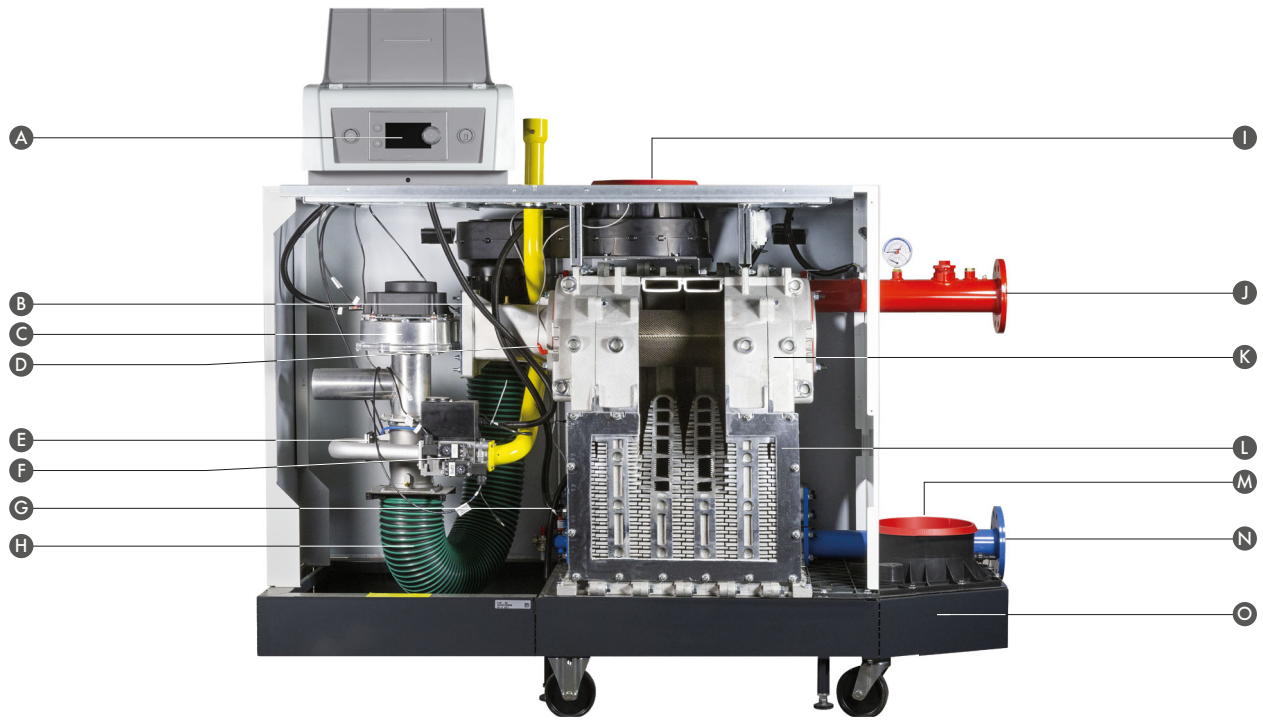

C340_Q0003

- A Control panel
- B Non-return flap
- C Fan
- D Ignition/ionisation electrode

- E Venturi
- F Gas multiblock
- G Return temperature sensor
- H Air inlet flexible

- I Air inlet
- J Heating flow
- K Cast aluminium/silicium exchanger
- L Exchanger inspection hatch

- M Flue gas nozzle
- N Heating return
- O Base frame on pivoting wheels

C 340-... AND C 640-...

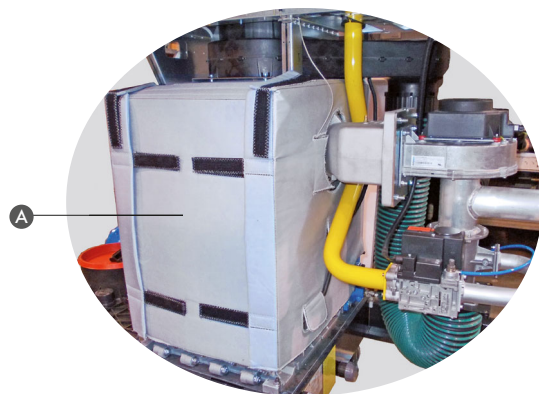

C330ECO_Q0022

- A Insulation from exchanger

C 640-...



C340_Q0002

- A Flue gas collector
- B Air inlet

- C Control panels
- D Base frame on pivoting wheels

CONTROL PANEL

OF THE C 340-... AND C 640-... BOILERS

INSTALLATION WITH ONLY 1 C 340-... DIEMATIC EVOLUTION BOILER

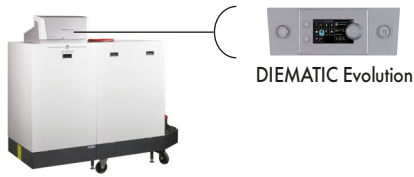

C 340-...

SECONDARY CIRCUITS THAT CAN BE CONNECTED

• For direct control of 1 circuit:

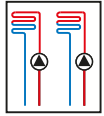

2 x direct

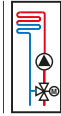

with valve

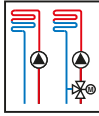

direct
+ 1 valve

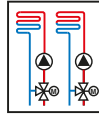

2 x valve

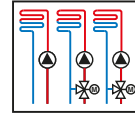

direct
+ 2 x with valve

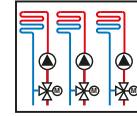

3 x with valve

OPTIONS

as standard

1 sensor
AD199



1 sensor
AD199



2 sensors
AD199



1 sensor
AD199



+ 1 PCB + sensor
AD249



2 sensors
AD199



+ 1 PCB + sensor
AD249



OTHER ACCESSORIES

PCB SCB-09

Connection of a gas tightness gas valve controller and gas pressure switch

CASCADE INSTALLATION WITH C 340-... OR C 640... BOILER WITH 0-10V CONTROL

FOR INSTALLATION WITH EXTERNAL CONTROL CABINET



C 340-... DIEMATIC Evolution

C 340-... DIEMATIC Evolution

C 340-... DIEMATIC Evolution



SECONDARY CIRCUITS THAT CAN BE CONNECTED

The boiler room control cabinet will manage all the installed secondary circuits.

STANDARD AVAILABLE INPUTS

0-10V input directly integrated as standard in the boiler on PCB SCB-10. Possibility of setting an ON/OFF input dry contact per boiler.

CONTROL PANEL

OF THE C 340-... AND C 640-... BOILERS

CASCADE INSTALLATION WITH 2 UP TO 8 C 340-... BOILERS OR 1 UP TO 4 C 640-... IN WHICH ALL BOILERS ARE EQUIPPED WITH A DIEMATIC EVOLUTION CONTROL PANEL



Boiler 1 (master)
C 340-... DIEMATIC Evolution

Boiler 2 (secondary)
C 340-... DIEMATIC Evolution

Boiler 3 (secondary)
C 340-... DIEMATIC Evolution

C340_00001

SECONDARY CIRCUITS THAT CAN BE CONNECTED ON C 340 BOILER

						<p>OTHER ACCESSORIES Per C 340 boiler:</p> <p>PCB SCB-13 Control of a hydraulic isolation valve Réf. 7750338</p> <p>PCB SCB-09 Control of an external gas valve Réf. 7663076</p> <p>S-BUS cable For communication between boilers AD309 and AD310</p> <p>Cascade flow sensor AD199 or AD250</p>
2 x direct	with valve	direct + 1 valve	2 x valve	direct + 2 x with valve	3 x with valve	
OPTIONS						
as standard	1 sensor AD199 	1 sensor AD199 	2 sensors AD199 	1 sensor AD199 + 1 PCB + sensor AD249 	2 sensors AD199 + 1 PCB + sensor AD249 	

SECONDARY CIRCUITS THAT CAN BE CONNECTED ON C 640 BOILER

			<p>OTHER ACCESSORIES Per C 640 boiler:</p> <p>PCB SCB-13 Control of a hydraulic isolation valve Réf. 7750338</p> <p>PCB SCB-09 Control of an external gas valve Réf. 7663076</p> <p>S-BUS cable For communication between boilers AD309 and AD310</p> <p>Cascade flow sensor AD199 or AD250</p>
4 x with valve	2 x direct + 4 x with valve	6 x with valve	
OPTIONS			
4 sensors AD199 	4 sensor AD199 	4 sensors AD199 + 2 PCB + sensor AD249 	

NOTE: do not forget to order « cascade flow sensor », package AD250 or AD199 and bus cable AD308 with a C640.

ADDITIONAL FUNCTIONS

OF THE DIEMATIC EVOLUTION CONTROL PANEL

The table below indicates the additional functions available for each control panel, with various options.

DESCRIPTION OF THE ADDITIONAL FUNCTIONS		AVAILABILITY
Input 0 - 10 V, configurable (1)		X
Output 0 - 10 V, configurable (1)	• a 0 -10 V modulating pump command	X
	• PWM modulating pump command	X
ON/OFF signal input (1)		X
Dry contact status output (1)		X
Control of a hydraulic isolation valve: in the case of a cascade, enabling isolation of an inactive boiler to avoid heat losses		SCB-13 Option
Control of a gas pressure switch (1)		X
Control of a water pressure switch (1)		X
Check of the tightness of the gas train		SCB-09 Option
Connection of an outside sensor (1)		X

(1) Functions available in series with the DIEMATIC Evolution control panel

CONTROL PANEL

OF THE C 340-... AND C 640-... BOILERS

PRESENTATION OF THE DIEMATIC EVOLUTION CONTROL PANEL

The **DIEMATIC Evolution** is a very advanced control panel, which includes electronic programmable regulation to modulate the boiler temperature by activating the modulating burner according to the outside temperature and also to the room temperature, if an interactive remote control is connected.

As standard, DIEMATIC Evolution control panel is capable of automatically operating a central heating installation with a direct circuit and 1 circuit with mixing valve (the flow sensor for the mixing valve - package AD199 - must be ordered separately, however!).

By connecting another « PCB + sensor 1 valve circuit » (option package AD249), it is therefore possible to control up to 3 circuits in total.

The connection of a domestic hot water sensor allows programming and regulation of a DHW circuit (Package AD212 - option).

This control system has been specifically developed to enable **optimal management of systems combining different heating generators** (boiler + heat pump or + solar system...). This control enables the installer to parameterise the entire heating system, regardless of its degree of complexity.

SPECIAL CASE: C 640-...

The C 640-... are equipped with two Diematic Evolution panels based on the cascade principle.

Pictograms with info on the installation (circuit temperature, outside air temperature, circuits, etc.)

Date and time

Button to go back to the previous level or menu

On/Off button

Button for the main display

Status indicator LED:

- continuous green = normal operation
- flashing green = warning
- red = blockage
- continuous red = locked

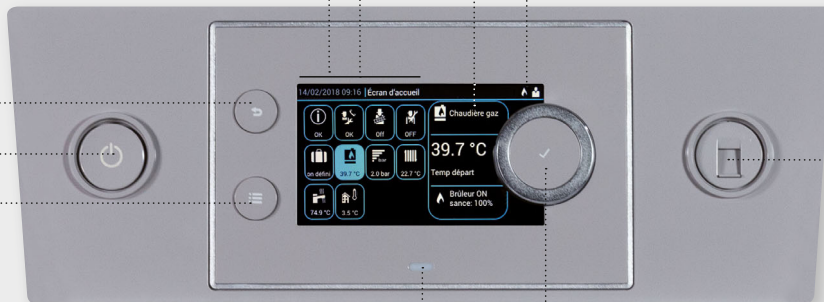

Dialogue and information fields

Current menu display

Socket for the PC connection

C-140_Q0010

Rotary/push button:

- turn to select a menu or parameter
- press to confirm the selection

OPTIONS OF THE DIEMATIC EVOLUTION CONTROL PANEL



SENSOR FOR DOMESTIC HOT WATER - PACKAGE AD212

It allows to control a domestic hot water tank, with priority and time programm functions.



FLOW SENSOR DOWNSTREAM OF MIXING VALVE (LENGTH 2.5 m) - PACKAGE AD199

This sensor is necessary for connecting the 1st circuit with mixing valve on a boiler equipped with the DIEMATIC Evolution control panel.



SENSOR FOR BUFFER TANK OR CASCADE FLOW SENSOR- PACKAGE AD250

Comprises 1 sensor for managing a buffer tank with a boiler equipped with a DIEMATIC Evolution control panel



PCB + SENSOR FOR 1 MIXING VALVE - PACKAGE AD249

It is used to control a mixing valve with an electromechanical or electrothermal motor. The PCB is integrated in the DIEMATIC Evolution panel and is connected using plug-in connectors. DIEMATIC Evolution can house 1 "PCB + sensor" option, enabling it to control 1 additional mixing valve.

OPTIONS

OF THE DIEMATIC EVOLUTION CONTROL PANEL

OPTIONS OF THE DIEMATIC EVOLUTION CONTROL PANEL



VM_Q0009

DIEMATIC VM EVOLUTION (WALL-HUNG) CONTROL UNIT- PACKAGE AD315

The VM DIEMATIC EVOLUTION electronic control system, accessories integrated into a wall unit, allows 3 heating circuits and 2 DHW circuits to be controlled and regulated; each of the heating circuits can be a direct circuit or a circuit with a 3-way motorised mixing valve.

It is possible to link together up to 8 VM DIEMATIC EVOLUTION control systems and to thereby create numerous combinations, regardless of the type of installation:

- The VM DIEMATIC EVOLUTION can be used in conjunction with one or more generators equipped with the DIEMATIC EVOLUTION or IniControl 2
- The DIEMATIC VM EVOLUTION can be integrated into a DIEMATIC iSystem via the Modbus as a secondary only.
- The VM DIEMATIC EVOLUTION can also be used on its own in standalone mode to regulate the heating and DHW circuits depending on the outdoor temperature (FM46 sensor to be ordered separately).
- The VM DIEMATIC EVOLUTION can also control a cascade of boilers equipped with a DIEMATIC EVOLUTION control panel
- The VM DIEMATIC EVOLUTION also has a 0-10 V input that can be configured for on/off phone control.

Dimensions : length: 320 mm, height: 260 mm, depth: 130 mm

International Protection marking: IP 21 - Reversible hinged door, lockable and sealable



REG_Q0003

GTW08 L-BUS-MODBUS GATEWAY - PACKAGE AD332

Many boiler room networks use the Modbus as communication protocol for Building Management System (BMS). Despite being a non-proprietary protocol, the Modbus has parameters that may differ from one application to another. This is why our communication gateways that transform our proprietary buses into standard Modbus RTU RS485 have adjustable parameters such as speed, parity and stop bit.



MCA_Q032+MCA_Q0149+MCA_Q0151+MCA_Q015

S.BUS CABLE WITH PLUGS, 1.5 M - PACKAGE AD308

S.BUS CABLE WITH PLUGS, 12 M - PACKAGE AD309

S.BUS CABLE WITH PLUGS, 20M - PACKAGE AD310

BUS TERMINAL - PACKAGE AD321

The BUS cable enables two boilers equipped with the DIEMATIC Evolution panel to be connected as part of a cascade installation.

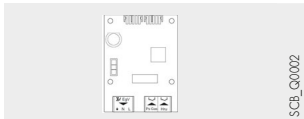

SCB_Q0002

PCB SCB-09 - REF. 7663076 (1)

PCB with pressure switch connection and gas valve tightness controller.

This PCB has to be mounted in the control panel . For C 640 two PCBs SCB 09 are needed.

(1) order two for C 640-...



SCB_Q0001

PCB SCB-13 - REF. 7750338 (1)

PCB that can control a hydraulic isolation valve for cascade.

This PCB has to be mounted in the control panel . For C 640 two PCBs SCB 13 are needed.

(1) order two for C 640-...

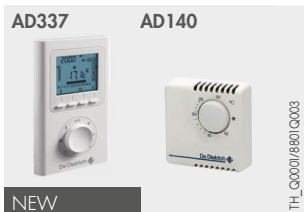

TH_Q0001/8101Q003

NEW

WIRED PROGRAMMABLE ROOM THERMOSTAT - PACKAGE AD337

NON-PROGRAMMABLE ROOM THERMOSTAT - PACKAGE AD140

Programmable thermostats provide weekly programming and regulation of the heating according to the various operating modes: "Automatic" depending on the programming, "Permanent" at a set temperature or "Holiday". The wireless version includes an emitter module which is fixed to the wall near the boiler.

The non-programmable thermostat is only used to regulate the room temperature based on the specific setpoint.



SMARTC_Q007

WIRED WIFI SMART TC° ROOM THERMOSTAT (R-BUS) - PACKAGE AD324

This enables remote control of the heating and domestic hot water via an app which is free to download and simple to use, with the option of providing a professional with access to your installation (with authorisation).

It is used to remote control the installation, including programmed times of operation and access to settings such as checking the energy consumption using data logs.

Smart TC° can also be used as a standard thermostat without using Wifi or any other app, although you are recommended to keep it connected to the Internet to benefit from the latest updates.

OPTIONS

FOR C 340-... AND C 640-... BOILERS

BOILER OPTIONS



C330ECC_Q0009

2nd RETURN NOZZLE:

- C 340-280 AND C 640-560 - REF. S101776 (1)
- C 340-350 AND C 640-700 - REF. S101777 (1)
- C 340-430 AND C 640-860 - REF. S101778 (1)
- C 340-500 AND C 640-1000 - REF. S101779 (1)
- C 340-570 AND C 640-1140 - REF. S101780 (1)
- C 340-650 AND C 640-1300 - REF. S101781 (1)

These packages are used to differentiate the low and high temperature return circuits and thus to exploit condensation to the full. They include a 2nd return pipe and a water distribution pipe.
(1) order two for C 640-...



C310_Q0008

TIGHTNESS CHECKER FOR THE GAS TRAIN:

- HONEYWELL, FOR 5 TO 9 ELEMENTS - REF. 7745411 (1)
- DUNGS, FOR 10 ELEMENTS - REF. 7745412 (1)

It is adapted to the gas train and checks the tightness of the safety valves during the pre-sweep. If a leak is detected, the boiler goes into safety shutdown and the fault will be signalled by the DIEMATIC Evolution control panel.
(1) order two for C 640-...



C 340_Q0014

PRESSOSTAT GAZ MINI. POUR BLOC GAZ

- HONEYWELL, POUR 5 TO 9 ÉLÉMENTS - REF. 7745414 (1)
- DUNGS, POUR 10 ÉLÉMENTS - REF. 7745415 (1)

It is adapted to the gas train and in case of lack supply pressure it puts the boiler into safety shutdown and the fault will be signalled by the DIEMATIC Evolution control panel.
(1) order two for C 640-...



C330ECC_Q0006

LOW WATER PRESSURE SWITCH - REF. 7750082 (1)

(1) order two for C 640-...



C210_Q0009

AIR INTAKE FILTER - PACKAGE GS20 (1)

It is fitted to the combustive air inlet and obviates a fall in output if the pre-mix gas burner is clogged owing to it being in a dusty atmosphere.
(1) order two for C 640-...



CLEANING KNIFE

It allows the exchanger to be cleaned, which is accessed via the inspection trap in the body.
Delivered with the boiler.



C330ECC_Q0008

4 TO 8 HOLE ADAPTOR FLANGE FOR A PUMP - REF. S101775

COUNTER FLANGE:

- FLOW/RETURN - REF. 7606977
- 2nd RETURN - REF. 7606978

Delivered with screws and gaskets.
For C 640 2 sets of Counter Flange are needed

OPTIONS

FOR C 340-... AND C 640-... BOILERS

BOILERS OPTIONS



CONDENSATE NEUTRALISATION STATION WITH LIFT PUMP FOR BOILERS OR BOILERS IN A CASCADE INSTALLATION FOR:

- C 340-280 (BOILERS ≤ 300 KW) - PACKAGE SA4
- C 340-350 TO 650 AND C 640-560 TO 1300) - PACKAGE DU15

GRAVITY FLOW CONDENSATE NEUTRALISATION STATIONS FOR:

- C 340-280 TO 430 (BOILERS ≤ 450 KW) - PACKAGE SA3
- C 340-500 TO 650 AND C 640-560 TO 1300 (BOILERS ≤ 1300 KW) - REF. 7622256 ; DELIVERED IN 3 PACKAGES: 1 X SA9 + 2 X SA7

The condensates neutralization systems - packages SA4 and SA3 - are delivered with 25 kg neutralization granules, the condensates neutralization system ref. 7622256 is delivered with 2 loads of 25 kg and the neutralization system - package DU15 - with a 10 kg load ; they all delivered with their hydraulic and electrical connection accessories to fit easily on our boilers

PRINCIPLE

Acid condensates are conveyed via a reservoir filled with granulates before being sent to the wastewater network. An annual check of the system and particularly the effectiveness of granules by measuring the pH is necessary; where applicable it is necessary to replace the granules.

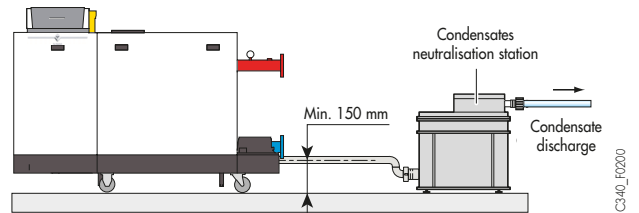

NEUTRALIZATION GRANULES FOR STATION:

- 10 KG - REF. 94225601 (TO ORDER AT THE SPARE PARTS DEPARTMENT)
- 25 KG - PACKAGE SA7

An annual check of the system and particularly the effectiveness of granules by measuring the pH is necessary; where applicable it is necessary to replace the granules.

DHW PRODUCTION

De Dietrich B... series independent DHW tanks with a capacity of 150 to 1000 litres can be used for domestic hot water production for individual and collective residences as well as for industrial and commercial premises. They are lined with food quality standard high quartz content vitrified enamel and protected by an anode (in magnesium for BLC/BPB... and B 650, impressed current anode "correx" for B 800 and 1 000). The specifications and performances of these tanks are given in the product catalogue and the technical leaflets.

OPTIONS

FOR C 340-... AND C 640-... BOILERS

FLUE SYSTEM OPTIONS

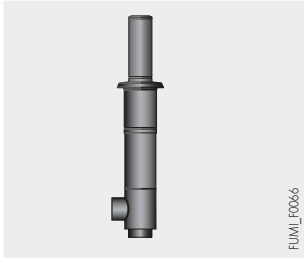

FUMI_F0066

VERTICAL AIR/FLUE GAS VENT (GALVANIZED ALUMINIUM)

- Ø 200/300 mm - REF. 51202
- Ø 250/350 mm - REF. 51203

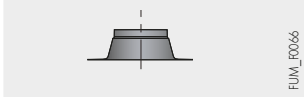

FUMI_F0066

FLASHING FOR FLAT ROOF:

- Ø 300 mm - REF. 46157
- Ø 350 mm - REF. 46150

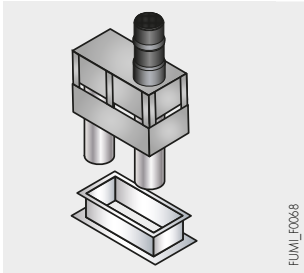

FUMI_F0068

VERTICAL FORCED FLUE 2 X Ø 350 mm - REF. 54443



C330ECO_Q0002

CONNECTION ADAPTER C 310 TO C 340 - REF. S103178

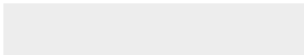

ADAPTER Ø 250 mm TO Ø 200 mm - REF. S103179



C330ECO_Q0010

FLUE CONNECTION KIT FOR 2 X C 340 - REF. S103118



C330ECO_Q0011

AIR INPUT COLLECTOR FOR C 640- REF. S103128

HYDRAULIC MODULES

FOR C 340-... BOILERS

HYDRAULIC MODULES FROM THE C 340

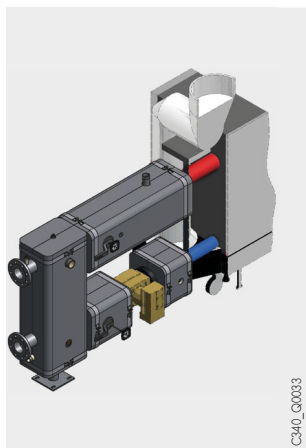

C340_Q0033

LOW LOSS HEADER CONNECTING SET FOR:

- C 340-280 - REF. 7673098
- C 340-350 - REF. 7673099
- C 340-430 - REF. 7673101
- C 340-500 - REF. 7673102
- C 340-570 AND 650 - REF. 7673103

The connection sets are composed by:

- 1 stainless steel flanged compensator on the flow,
- 1 connection in R 1 1/2" on flow for safety valve,
- 2 flanged sleeves,
- 2 isolation valves on the flow and return,
- 1 low loss header with adjustable feet, 1 immersion sleeve in R 1/2" for the flow sensor, plug for bleed valve aerator, R 1" connection for the installation expansion vessel, R 1 1/4" drain connection, Rp 1/4" connection for magnetic bar (option),
- 1 modulating pump managed by 0-10V of the boiler control panel,
- Insulating shells protected by an aluminum foil covering and secured by strapping.

The delivery includes all screws and gaskets.

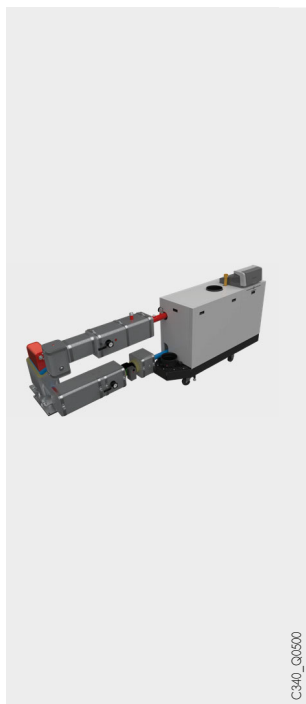

C340_Q0500

PLATE HEAT EXCHANGER CONNECTING SET:

- C 340-280 - REF. 7768167
- C 340-350 - REF. 7768168
- C 340-430 - REF. 7768169
- C 340-500 - REF. 7768170
- C 340-570 - REF. 7768171
- C 340-650 - REF. 7768172

The connection sets are composed by:

- 1 stainless steel flanged compensator on the flow,
- 1 connection in R 1 1/2" on flow for safety valve,
- 2 flanged sleeves,
- 2 isolation valves on the flow and return,
- 1 brazed plate heat exchanger,
- 1 modulating pump managed by 0-10V of the boiler control panel,
- Insulating shells protected by an aluminum foil covering and secured by strapping.

The delivery includes all screws and gaskets.

MODEL	REF.	PRIMARY T° (°C)	SECONDARY T° (°C)	FLOW (m³/H)	MAX PRESSURE LOSSES (KPA)	Ø OF CONNECTION
C 340...						
280 kW	7768167	85 / 65	80 / 60	12	20	2"
350 kW	7768168	85 / 65	80 / 60	15	20	2"
430 kW	7768169	85 / 65	80 / 60	18.2	20	2"
500 kW	7768170	85 / 65	80 / 60	21.4	20	2" 1/2
570 kW	7768171	85 / 65	80 / 60	24.7	20	2" 1/2
650 kW	7768172	85 / 65	80 / 60	28	20	2" 1/2

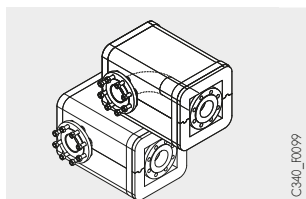

C340_F0099

KIT WITH INSULATED FLOW/RETURN ELBOWS DN 80 - REF. 7674655

These elbows allow the connection of low loss header or plate heat exchanger sets on the left or on the right of the C 340 boiler.



C-64RECO_Q0003

MAGNET FILTER CARTRIDGE- REF. 7613415

Cartridge to be mounted into the low loss header of low loss header kit for collecting magnetite sludge.

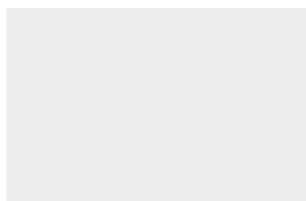

ISOLATION VALVES (NOT PROVIDED)

In the context of a cascade of boilers where we do not have a pump per boiler, we recommended the use of isolation valves to prevent recirculation in the heat exchanger when a boiler is shut down. These valves are controlled by the boiler (provide SCB-13 board ref. 7750338).

RECOMMENDED MODEL:

2-way butterfly valves DN 80 with servomotor with return to 0 by lack of current or return spring.
Power supplies 230V On/Off. Timing as short as possible / 90 ° (Timing to be set in boiler parameter during commissioning).

HYDRAULIC MODULES

FOR C 640-... BOILERS

HYDRAULIC MODULES FROM THE C 640

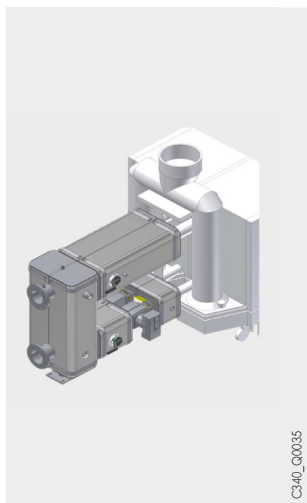

COMPLETE HYDRAULIC SET « DUOCONNECT » FOR:

- C 640-560 - REF. 7622302
- C 640-700 - REF. 7622304
- C 640-860 - REF. 7622306
- C 640-1000 - REF. 7622307
- C 640-1140 AND 1300 - REF. 7622308

The connection sets are composed by:

- 2 stainless steel compensators on flow connections
- 2 intermediate piping with flanges and free connection R1 1/2" for the safety valve,
- 2 flanged sleeves,
- 4 valves on flow and return connections,
- 1 decoupling low loss header with adjustable foot, 1/2" reservation for the system sensor, 1/2" connection for air vent, R 1" connection for expansion vessel, R 1 1/2" rain away, R 2" connection for an additional generator, Rp 1 1/4" for magnetic bar (available optional),
- 2 flanged return connections with R 1 1/4" connectors for boiler expansion vessel,
- 2 high energy efficiency pumps (IEE) : ≤ 0.23 managed by 0-10V of the boiler control panel,
- Insulating shells protected by an aluminum foil covering and secured by strapping.

The delivery includes all screws and gaskets.

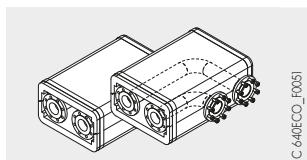

KIT WITH INSULATED FLOW/RETURN ELBOWS DN 80 FOR HYDRAULIC SET - REF. 7613414

These elbows allow the connection « DuoConnect » sets on the left or on the right of the C 640 boiler.

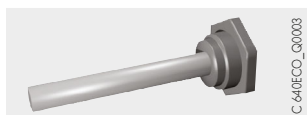

MAGNET FILTER CARTRIDGE- REF. 7613415

Cartridge to mounted into the low loss header of the «DuoConnect» sets for sludge collect.

TECHNICAL SPECIFICATIONS

MAIN DIMENSIONS OF THE BOILERS + HYDRAULIC MODULES

LOW LOSS HEADER CONNECTING SET

• direct connection

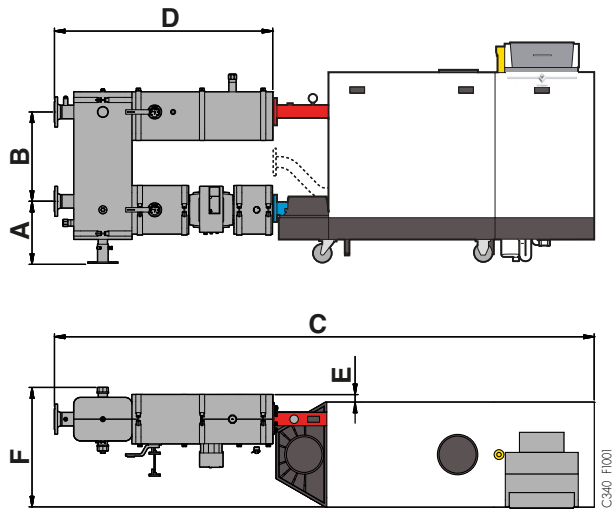

	A	B	C	D	E	F
C 340-280 to 650	423	600	3 624	1 465,5	52	764
C 640-560 to 1300	352	655	3 604	1 405	-	600

• side connection
with insulated flow/return elbows

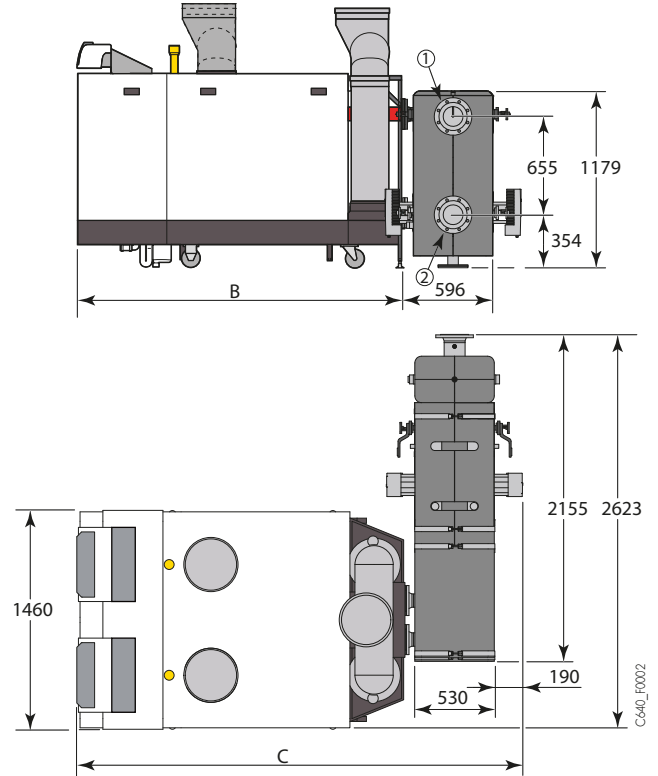

	B	C
C 640-560 to 860	1 862	2 648
C 640-1 000 to 1300	2 172	2 958

① Heating flow Ø DN 25/PN 16

② Heating return Ø DN 25/PN 16

PLATE HEAT EXCHANGER CONNECTING SET

• direct connection

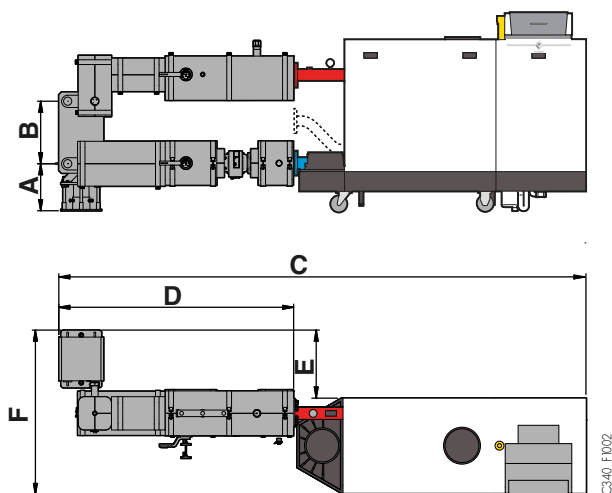

	A	B	C	D	E	F
C 340-280	370	520	3 528	1 676	646	1 353
C 340-350	370	520	3 528	1 676	672	1 379
C 340-430	370	520	3 528	1 676	791	1 498
C 340-500	370	682	3 605	1 753	583	1 290
C 340-570	370	682	3 605	1 753	597	1 304
C 340-650	370	682	3 605	1 753	597	1 304

INFORMATION REQUIRED

FOR INSTALLATION

STATUTORY INSTRUCTIONS ON INSTALLATION AND MAINTENANCE

Installation and service have to be done according to local regulation

INSTALLATION IN BOILER ROOM

C 340/640-... boilers are fitted with a castor + rail guidance system allowing them to be easily put into position: it is sufficient to roll the boiler from the pallet to its desired position (using the top of the packaging case placed in front of the pallet head as an unloading ramp).

The dimensions shown are the minimum recommended dimensions (in mm) for providing adequate access around the boiler.

NOTE

For installations with several boilers in cascade, these same dimensions should be respected for each boiler.

• C 340

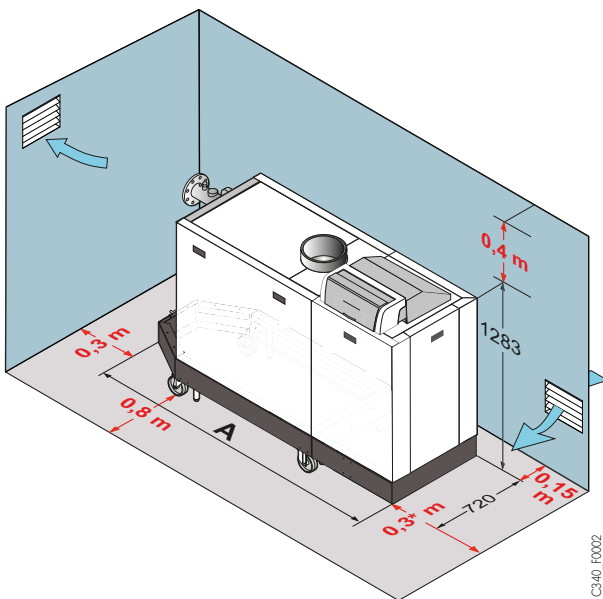

C340_F0002

* 800 mm in case of orientation of the control panel in frontal position

	A (mm)
C 340-280	1 862
C 340-350	1 862
C 340-430	1 862
C 340-500	2 172
C 340-570	2 172
C 340-650	2 172

• C 640

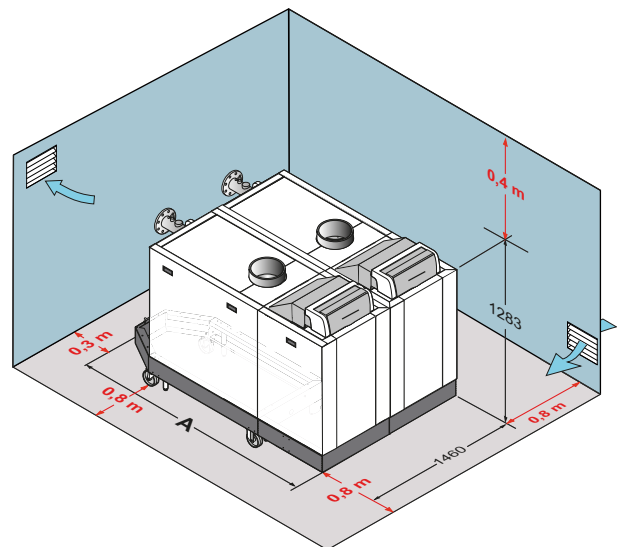

C640_F0003

	A (mm)
C 640-560	1 862
C 640-700	1 862
C 640-860	1 862
C 640-1 000	2 172
C 640-1 140	2 172
C 640-1300	2 172

INFORMATION REQUIRED

FOR INSTALLATION

INSTALLATION

As far as possible, the protective packaging around the boiler must only be removed once the boiler is in its definitive position. However, for practical transport reasons and for passage through doors and along corridors, it may be necessary to dismantle certain parts of the boiler.

The elements which can be dismantled are:

- the panels,
- the flue system and gas components,
- part of the base frame.

The diagram and control panel below give the dimensions of the largest piece transported (the base frame with the boiler body and hydraulic connections).

	L (mm)
C 340-280, C 340-350, C 340-430	1 160
C 640-560, C 640-700, C 640-860	1 160
C 340-500, C 340-570, C 340-650	1 469
C 640-1000, C 640-1140, C 640-1300	1 469

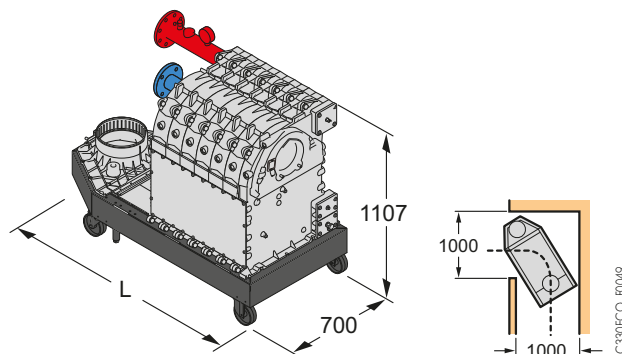

BOILER ROOM VENTILATION

The cross-section of the boiler room ventilation (through which combustive air is taken in) must comply with the prevailing standard.



In order to avoid damage to boilers, it is necessary to prevent the contamination of combustion air by chloride and/or fluoride compounds, which are particularly corrosive.

These compounds are present, for example, in aerosol spray cans, paints, solvents, cleaning products, washing powders/liquids, detergents, glues, snow clearing salts, etc.

It is therefore necessary:

- To avoid sucking in air discharged from premises using such products: hairdressers, dry cleaners, industrial premises (solvents), premises containing refrigeration systems (risk of leaking refrigeration fluid), etc.
- To avoid the storage of such products close to boilers.

Please note that, if the boiler and/or its peripherals become corroded by chloride and/or fluoride compounds, our contractual warranty cannot be invoked.

GAS CONNECTION

Compliance with prevailing instructions and regulations is mandatory. In all cases, a sectional valve is fitted as close as possible to the boiler. A filter should be fitted to the gas supply inlet immediately after the sectional valve.

The pipe diameters must be defined in accordance with prevailing specifications.

Gas supply pressure:

- 20 mbar on natural gas H,
- 25 mbar on natural gas L,
- 300 mbar on natural gas H or L with pressure regulator.

GAS STORAGE BOTTLES

Gas storage bottles are one of the solutions employed to correct the problem of the « min » or « max » pressure switches fitted to the gas burners being tripped unnecessarily. This kind of tripping is related to the inertia of the gas regulator system, which causes partial vacuum and overpressures in the gas mains pipe when the burners start up or shut down.

The volume calculation for a storage bottle can be performed using the software that we offer, in particular DIEMATOOLS, which is accessible on our Internet site, reserved for professionals.

INFORMATION REQUIRED

FOR INSTALLATION

ELECTRICAL CONNECTION

This must comply with the prevailing standard.

NOTES

- The sensor cables must be separated from the 230 V circuits by at least 10 cm,
- In order to protect the pump antifreeze and cleaning functions, we recommend not switching off the boiler at the main switch.
- Depending on the quality of the power supply network, we recommend the use of an isolation transformer.

HYDRAULIC CONNECTIONS

IMPORTANT

The principle of a condensation boiler is to recycle the energy contained in the water vapour in the combustion gases (latent vaporisation heat). Consequently, to achieve an annual operating efficiency in the order of 108%, it is necessary to size the heating surfaces in such a way as to obtain low return temperatures, below the dew point (e.g. underfloor heating, low temperature radiators, etc.) during the entire heating period.

CONDENSATES DISCHARGE

It must be connected to the waste water discharge system. The connection must be removable and the flow of condensates visible. The connections and pipes must be in corrosion-resistant material.

Condensates neutralisation stations are available as optional equipment. (see page 13).

CONNECTION TO THE HEATING CIRCUIT

C 340/640-... boilers must only be used in closed circuit heating installations. The central heating systems must be cleaned to eliminate the debris (copper, strands, brazing flux) linked to the installation of the system and deposits that can cause malfunctions (noise in the system, chemical reaction between metals). More particularly, if fitting a boiler to an existing installation, it is strongly recommended that you clear sludge out of the system before installing the new boiler. After carrying out this work, particular monitoring of the installation may be necessary both in respect of the water in the network and the quality of the water used for topping it up in order to be in full control of the consequences. Suitable filters may be necessary in some cases.



After such interventions, special attention will be paid to the quality of the filling water for the installation in order to ensure performance expected from the new boiler.

REQUIREMENTS ON HEATING WATER

HEAT EXCHANGER MATERIAL		ALUMINIUM
HEAT EXCHANGER TYPE		SECTIONS
PROPERTY	UNIT	250 - 1300 KW
Degree of acidity (untreated water)	pH	6.5 - 9.0
Degree of acidity (treated water)	pH	6.5 - 9.0
Conductivity at 25°C	µS/cm	≤ 800
Chlorides	mg/l	≤ 150
Sulphates	mg/l	≤ 50
Other components	mg/l	-
Total water hardness (German)	°dH	≤ 8.4
Total water hardness (French)	°fH	≤ 15.0
Total water hardness (English)	°e	≤ 10.5
CaCO ₃	nmol/l	≤ 1.5

WATER TREATMENT

If, however, to meet the fill water quality requirements, it is necessary to resort to water treatment, please:

- Call on a water treatment specialist who will have to ensure the water quality complies with the mix of materials present in the installation, taking into account all of its components.

FLUE CONNECTION

Flue connection must comply with local regulations and standards

FLUE SYSTEMS

FOR C 340-... AND C 640-... BOILERS

C 340-...

6 7 CLASSIFICATION B_{23P} - CHIMNEY boiler alone

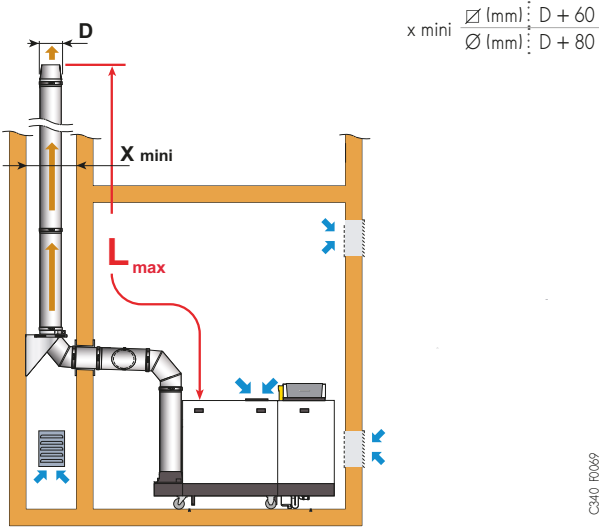

BOILER TYPE	L _{MAX} (m) (I)			
	Ø 150 mm	Ø 180 mm	Ø 200 mm	Ø 250 mm
C 340-280	20 m	50 m	50 m	50 m
C 340-350	11 m	30 m	50 m	50 m
C 340-430	8 m	22 m	39 m	50 m
C 340-500	7 m	18 m	32 m	50 m
C 340-570	5 m	13 m	24 m	50 m
C 340-650	-	10 m	18 m	50 m

(I) Calculated with rigid pipes and without terminal

C 640-...

6 7 CLASSIFICATION B_{23P} - CHIMNEY boiler alone

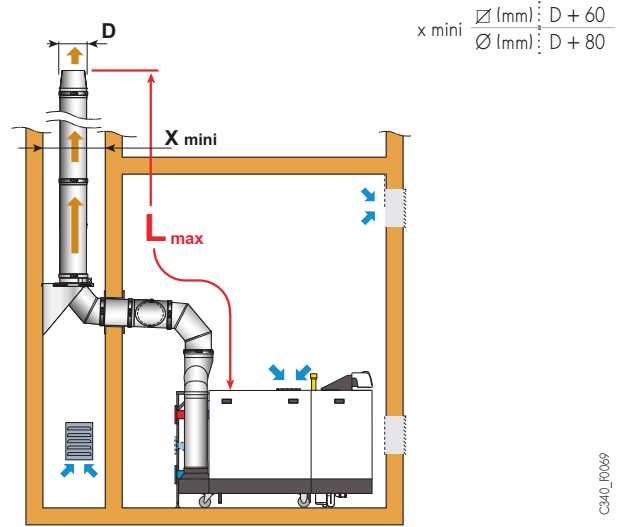

BOILER TYPE	L _{MAX} (m) (I)		
	Ø 200 mm	Ø 300 mm	Ø 350 mm
C 640-560	15 m	50 m	50 m
C 640-700	6 m	50 m	50 m
C 640-860	-	50 m	50 m
C 640-1 000	-	39 m	50 m
C 640-1 140	-	26 m	50 m
C 640-1 300	-	19 m	50 m

(I) Calculated with rigid pipes and without terminal

C 340-... AND C 640-...

6 7 CLASSIFICATION B_{23P} - CHIMNEY installation in cascade

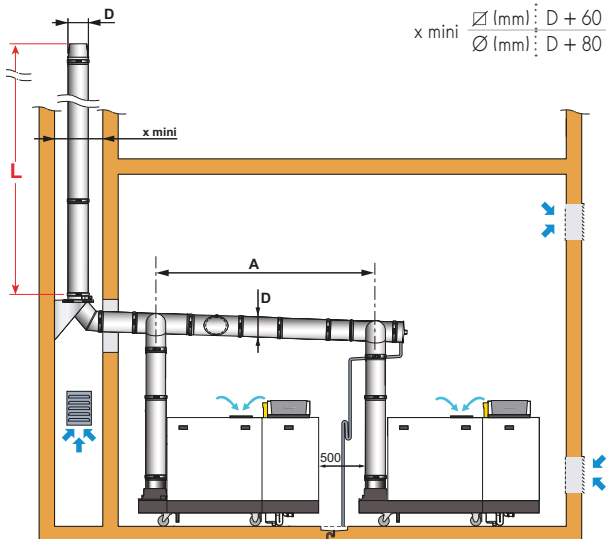

BOILER TYPE	A mm
C 340-280, C 340-350, C 640-560, C 640-700	2 100
C 340-430, C 340-500, C 340-570, C 340-650 C 640-860, C 640-1000, C 640-1140, C 640-1300	2 490

FLUE SYSTEMS

FOR C 340-... AND C 640-... BOILERS

MAXIMUM ADMISSIBLE LENGTH L (L_{MAX} IN M) DEPENDING ON THE Ø OF THE PIPE D (IN MM) FOR VARIOUS "CASCADE" COMBINATIONS

NOTE

These lengths have been defined in accordance with the dimensional constraints given in the schematics above. For different dimensional constraints, consult us.

C 340-...

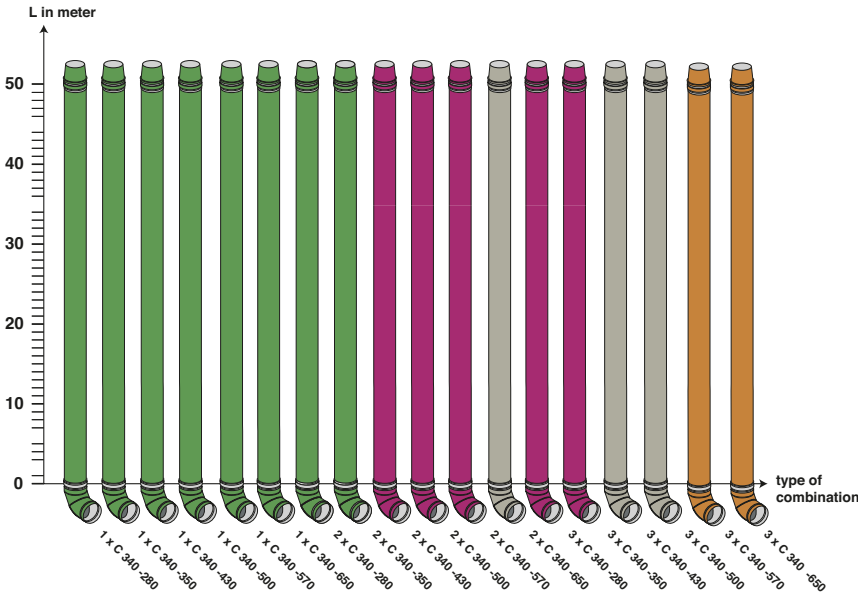

C340_F1000

C 640-...

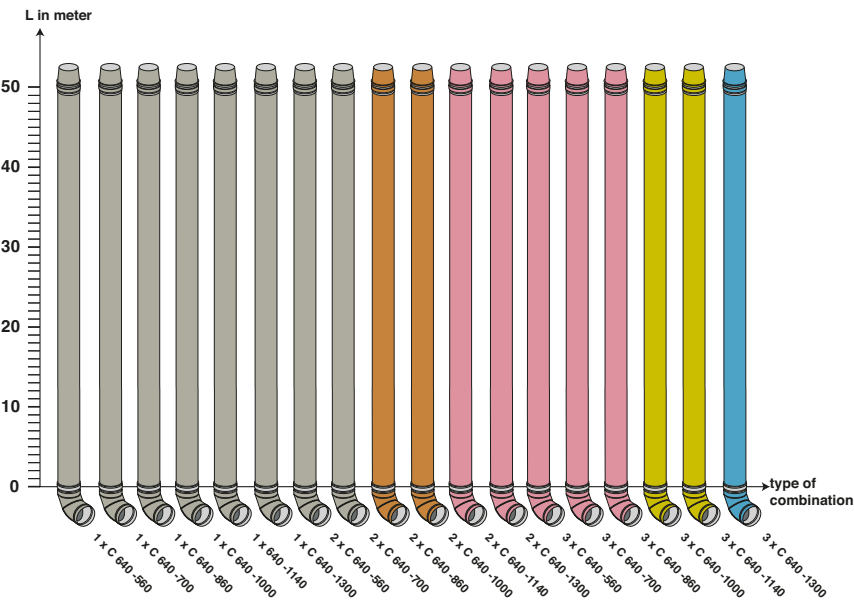

C340_F1000

- C 340-.../C 640-... boilers: working at 50/30°C
- Flue dampers integrated

NOTE

These lengths are given as a rough guide. De Dietrich's liability may in no event be invoked. For different combinations, consult us.

FLUE SYSTEMS

FOR C 340-... AND C 640-... BOILERS

C 340-...

6 7 CLASSIFICATION C₃₃ - CONCENTRIC VERTICAL FORCED FLUE

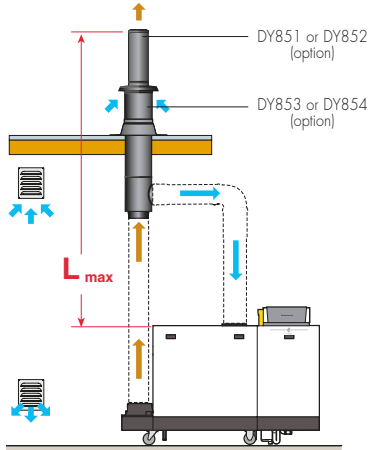

C340_F0011

BOILER TYPE	L _{max} (m) (I)		
	Ø 200 mm	Ø 250 mm	Ø 300 mm
C 340-280	84 m	100 m	100 m
C 340-350	42 m	100 m	100 m
C 340-430	26 m	100 m	100 m
C 340-500	20 m	100 m	100 m
C 340-570	10 m	68 m	100 m
C 340-650	4 m	48 m	100 m

(I) Calculated with rigid pipes and without terminal
NOTA: length also applicable in classification C₉₃.

C 640-...

6 7 CLASSIFICATION C₃₃ - CONCENTRIC VERTICAL FORCED FLUE

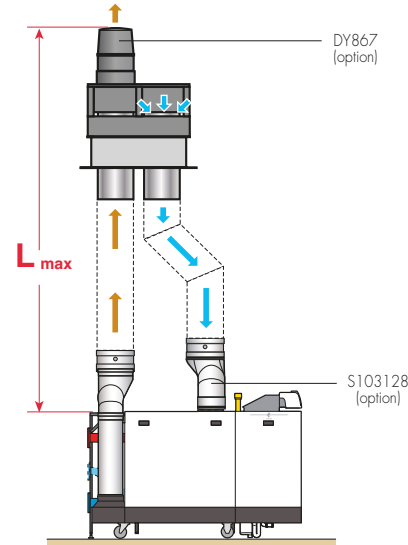

C340_F0011

BOILER TYPE	L _{max} (m) (I)		
	Ø 300 mm	Ø 350 mm	Ø 400 mm
C 640-560	100 m	100 m	100 m
C 640-700	86 m	100 m	100 m
C 640-860	52 m	100 m	100 m
C 640-1 000	26 m	70 m	100 m
C 640-1 140	10 m	32 m	48 m
C 640-1 300	-	20 m	24 m

(I) Calculated with rigid pipes and without terminal
NOTA: length also applicable in classification C₉₃.

6 7 CLASSIFICATION C₅₃ - SEPARATE AIR AND FLUE GAS PIPES (combustive air taken from outside)

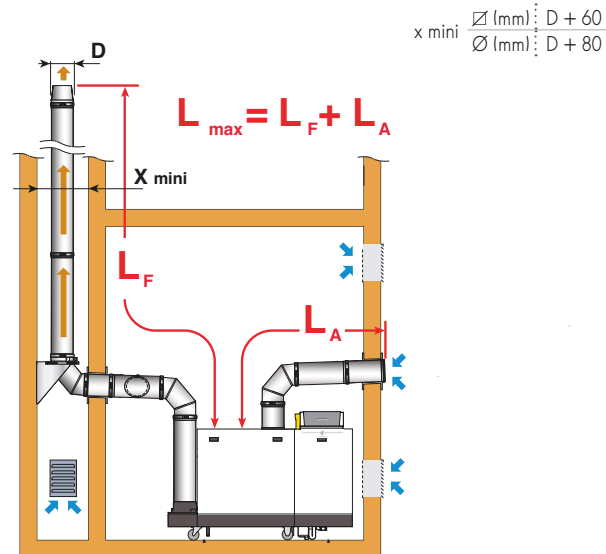

C340_F000

BOILER TYPE	L _{max} (m) (I)
	Ø 200 mm
C 340-280	61 m
C 340-350	30 m
C 340-430	20 m
C 340-500	16 m
C 340-570	10 m
C 340-650	5 m

(I) Calculated with rigid pipes and without terminal

6 7 CLASSIFICATION C₅₃ - SEPARATE AIR AND FLUE GAS PIPES (combustive air taken from outside)

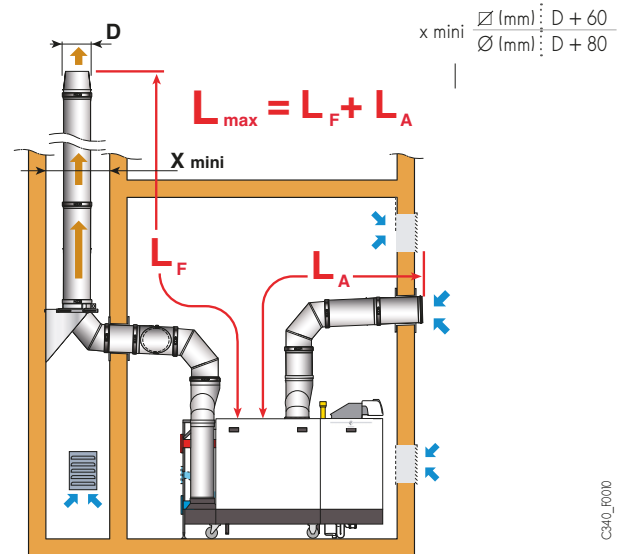

C340_F000

BOILER TYPE	L _{max} (m) (I)	
	Ø 300 mm	Ø 400 mm
C 640-560	100 m	100 m
C 640-700	48 m	100 m
C 640-860	24 m	100 m
C 640-1 000	-	90 m
C 640-1 140	-	28 m
C 640-1 300	-	-

(I) Calculated with rigid pipes and without terminal

INSTALLATION EXAMPLES

The examples presented below cannot cover the full range of installation scenarios which may be encountered. Their purpose is to draw the attention to the basic rules to be followed. A certain number of control and safety devices are represented but, in the last resort, it is up to the experts, consultant engineers and design departments to make the final decision on the control and safety devices to be used in the boiler room, depending on its specificities. In all events, it is necessary to abide by the codes of practice and the local and national regulations in force.

ATTENTION: For the connection of domestic hot water, a sleeve made of steel, cast iron or any other insulating material must be interposed between the hot water outlet and this pipework to prevent any corrosion to the spot welds, if the distribution pipework is made of copper.

EXAMPLES OF INSTALLATIONS

INSTALLATION OF A C 340 DIEMATIC EVOLUTION

- 1 underfloor heating circuit
- 1 domestic hot water circuit

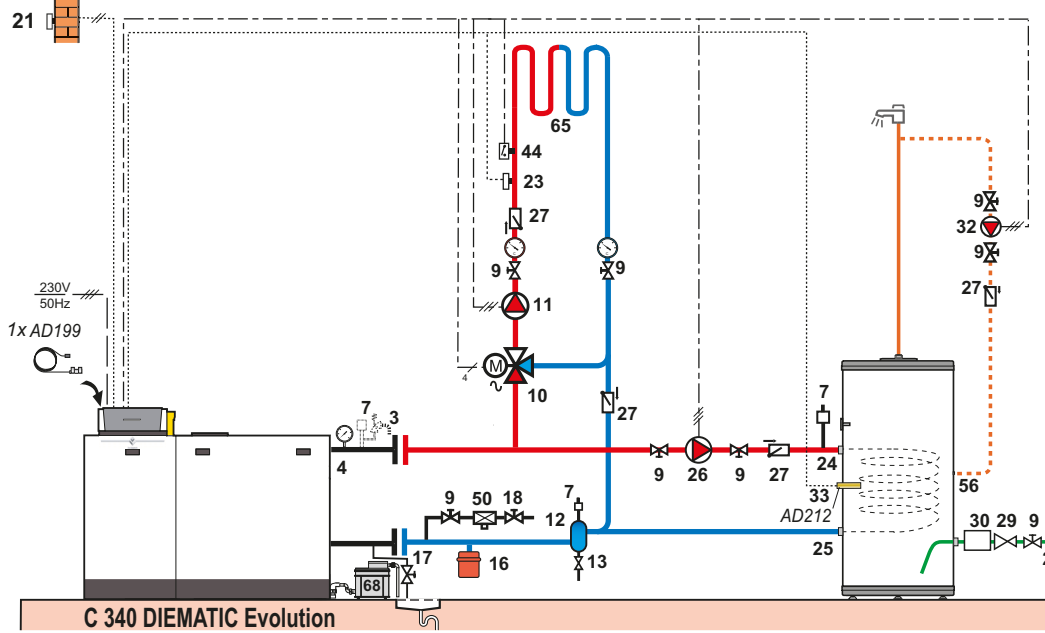

C340_F0003

INSTALLATION OF A C 340 DIEMATIC EVOLUTION

- 1 "radiator" circuit
- 1 circuit with mixing valve

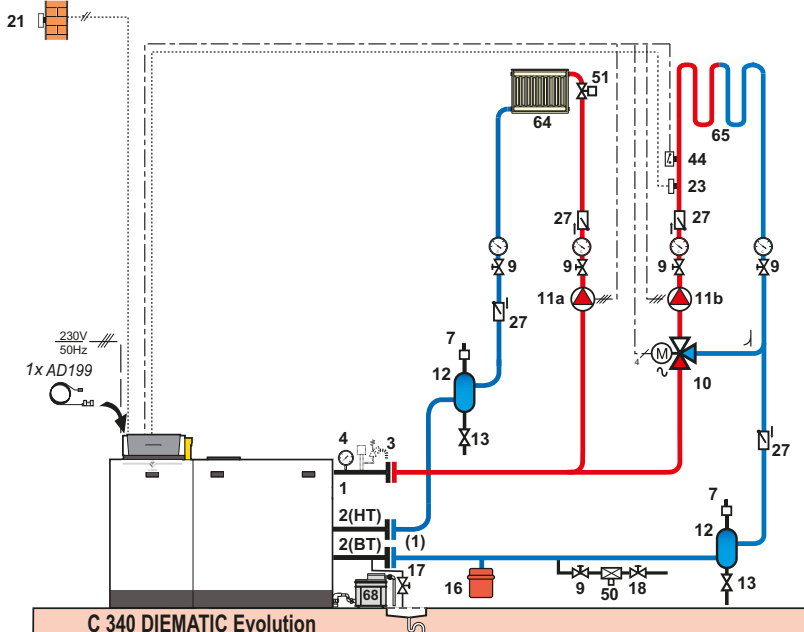

C340_F0004

INSTALLATION EXAMPLES

INSTALLATION OF 2 C 340 BOILERS IN CASCADE

- primary pump and decoupling cylinder
- 2 circuits with mixing valve
- 1 domestic hot water circuit

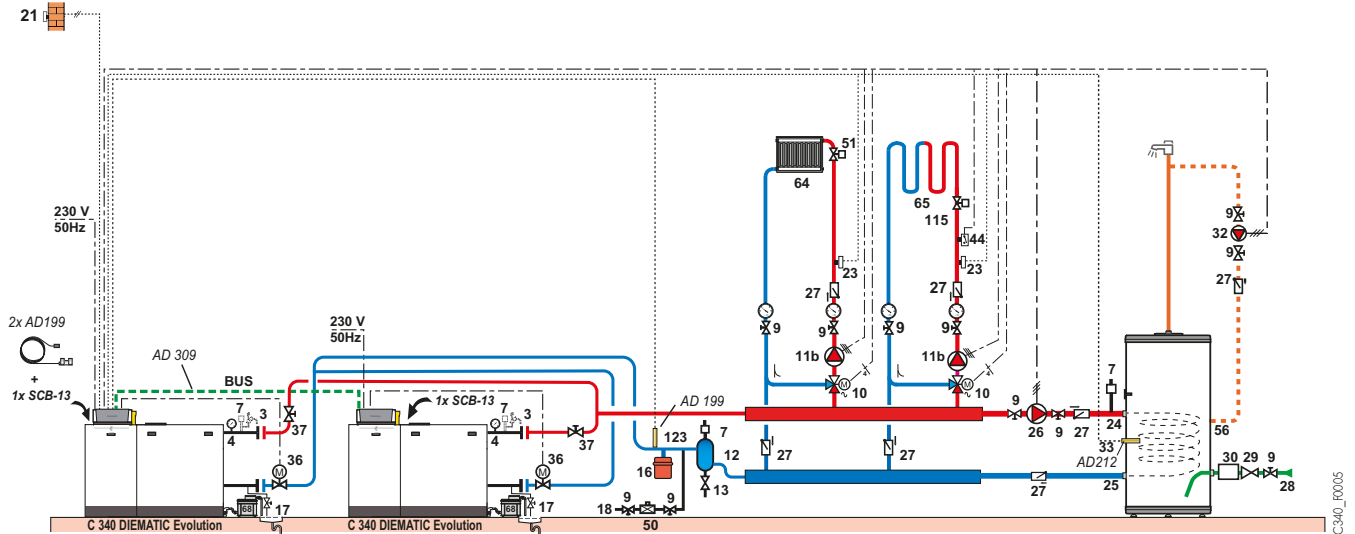

This diagram is only valid for 2 boilers maximum in cascade

INSTALLATION OF 2 C 340 BOILERS DIEMATIC EVOLUTION IN CASCADE (TYPE 1 PRIMARY CIRCUIT WITH INJECTION PUMPS)

- 2 circuits with mixing valve
- 1 instant domestic hot water circuit with primary storage

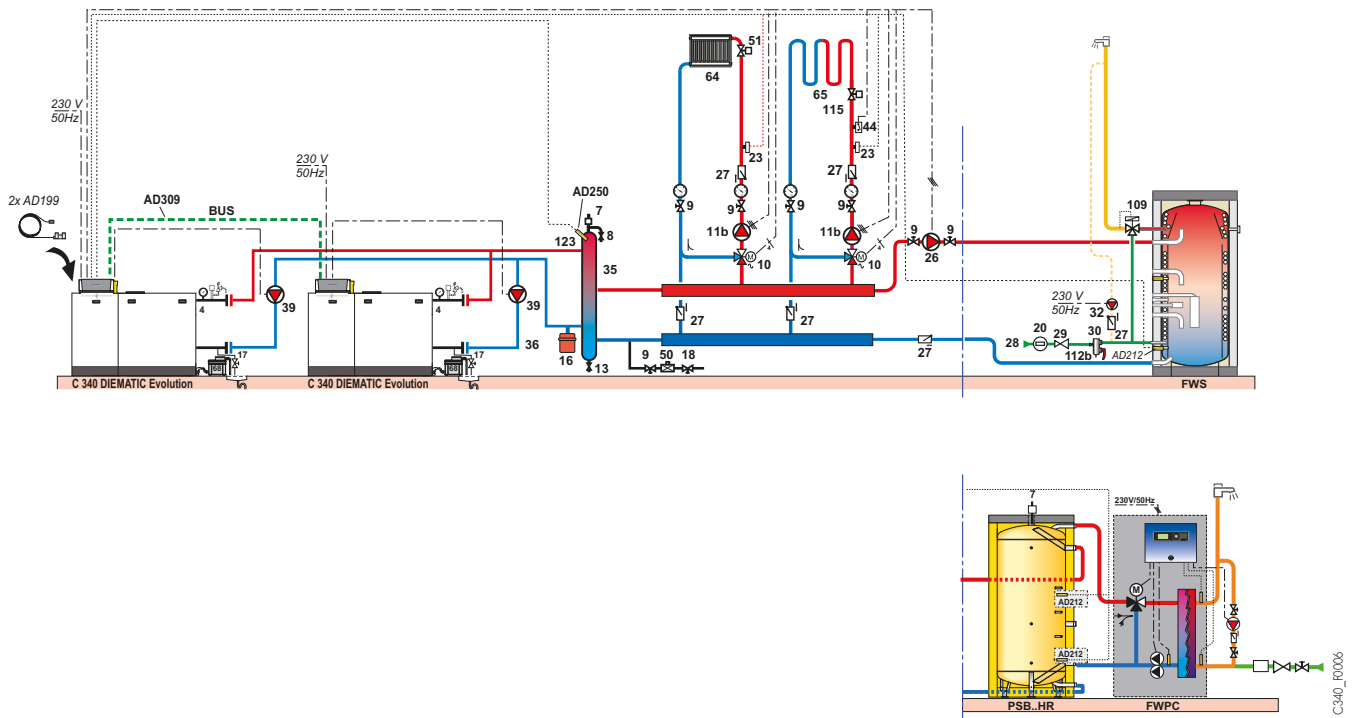

This configuration is possible for an installation containing up to 8 boilers in cascade.

KEY: see p. 27

INSTALLATION EXAMPLES

KEY

1	Heating flow	20	Water meter	30	Sealed safety device calibrated to 7 bars	56	DHW circulation loop return
2	Heating return	21	Outdoor temperature sensor	32	DHW loop pump (optional)	61	Thermometer
3	3-bar safety valve	22	Boiler sensor	33	DHW temperature sensor	65	Direct heating circuit: underfloor heating
4	Manometer	23	Outlet temperature sensor after mixing valve (delivered with the "FM48" package" PCB)	34	Primary pump	68	Condensate neutralisation system (optional).
7	Automatic air vent	24	Primary inlet on the DHW tank exchanger	35	Low-loss header / Decoupling cylinder	76	Diaphragm safety valve sealed and calibrated at 6 bar
8	Manual air vent	25	Primary outlet on the DHW tank exchanger	36	Motorised gate valve	115	Thermostatic distribution valve per zone
9	Shut-off valve	26	Domestic water load pump	37	Isolation valve	123	Cascade flow sensor (to be connected to the slave boiler)
10	3-way mixing valve	27	Non-return flap	39	Injection pump	130	Manual air vent degasser (Airstop)
11	Heating pump	28	Domestic cold water inlet	44	65°C limiter thermostat with manual reset for underfloor heating	133	Interactive remote control
12	Sludge separator	29	Pressure reducer	50	Disconnecter		
13	Flush valve			51	Thermostatic valve		
16	Expansion tank						
17	Draining valve (assembled delivery)						
18	Filling system						



BDR THERMEA France
SAS with corporate capital of 229 288 696 €
57, rue de la Gare - 67580 Mertzwiller
Tel. +33 3 88 80 27 00 - Fax +33 3 88 80 27 99
www.dedietrich-heating.com