

Fuel oil/gas-fired boilers

# GT 330



## Installation and Service Manual

# Declaration of conformity CE

The appliance complies with the standard model described in declaration of compliance **CE**. It is manufactured and distributed pursuant to the requirements of european directives.

The original of the declaration of compliance is available from the manufacturer.

**DÉCLARATION DE CONFORMITÉ CE  
EG - VERKLARING VAN OVEREENSTEMMING  
EC - DECLARATION OF CONFORMITY  
EG - KONFORMITÄT SERKLÄRUNG**

Fabricant/Manufacturer/Hersteller/Fabrikant : DE DIETRICH THERMIQUE  
Adresse/Adress/Adress : 57 rue de la gare  
Ville, pays Stad, Land/City, Country/Land, Ort : F-67580 MERTZWILLER

- déclare ici que les produit(s) suivant(s) : GT 330  
- verklaart hiermede dat de toestel(len) : 4, 5, 6, 7, 8, 9 éléments  
- this is to declare that the following product(s)  
- erklärt hiermit das die Produk(te)

produit (s) par : DE DIETRICH THERMIQUE  
: 57, rue de la Gare  
: F-67580 MERTZWILLER

répond/répondent aux directives CEE suivantes:  
voldoet/voldoen aan de bepalingen van de onderstaande EEG-richtlijnen:  
is/are in conformity with the following EEC-directives:  
den Bestimmungen der nachfolgenden EG-Richtlinien entspricht/entsprechen:

CEE-Directive:	92/42/CEE	normes appliquées, toegepaste normen:
EEG-Richtlijn:	92/42/EEG	tested and examined to the following norms:
EEC-Directive:	92/42/EEC	verwendete Normen:
EG-Richtlinie:	92/42/EEG	EN 303.2(1999), EN 304(1993)
	90/396/CEE	EN 303.3 (1999)
	90/396/EEG	
	90/396/EEC	
	90/396/EEG	
	73/23/CEE	DIN EN 50165(2001) EN 50165 (1997+A1:2001)
	73/23/EEG	DIN EN 60335-1(2003), EN 60335-1(2002)
	73/23/EEC	
	73/23/EEG	
	89/336/CEE	EN 55014-1(2000+A1:2001)
	89/336/EEG	EN 55014-2(1997+A1:2001)
	89/336/EEC	EN 61000-3-2(2000),
	89/336/EEG	EN 61000-3-3(1995+A1:2001)
	89/336/EEG	EN 61000-3-3(1995+A1:2001)
	89/336/EEG	EN55022 classe B (1998+A1 :2000)
	97/23/CEE	(art.3 section 3)
	97/23/EEG	(art. 3, lid 3)
	97/23/EEC	(article 3, sub 3)
	97/23/EEG	(Art. 3, Absatz 3)

**CE**  
1312

Mertzwiler, 15 décembre 2008

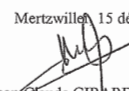
  
Jean-Claude GIRARDIN  
Directeur des opérations industrielles  
Recherche et développement

C000232-A

# Contents

<b>1</b>	<b>Introduction</b>	<b>5</b>
1.1	Symbols and abbreviations	5
1.2	General	5
1.2.1	Manufacturer's liability	5
1.2.2	Installer's liability	5
1.2.3	User's liability	5
1.3	Homologations	6
1.3.1	Certifications	6
1.3.2	Directive 97/23/EC	6
<b>2</b>	<b>Safety instructions and recommendations</b>	<b>7</b>
2.1	Safety instructions	7
2.1.1	Fire hazard	7
2.1.2	Risk of intoxication	7
2.1.3	Risk of being burnt	7
2.1.4	Risk of damage	7
2.2	Recommendations	8
<b>3</b>	<b>Technical description</b>	<b>9</b>
3.1	General description	9
3.2	Composition of the range	9
3.2.1	GT 330 S3: Boiler with basic control panel	9
3.2.2	GT 330 B3 : Boiler with electronic control panel	9
3.2.3	GT 330 DIEMATIC-m3: Boiler with DIEMATIC-m3 electronic control panel	10
3.2.4	GT 330 K3: Boiler with K3 control panel	10
3.3	Technical specifications	11
3.3.1	Boilers for following countries: France, Belgium, Spain, Italy, Luxemburg, Poland, Portugal	11
3.3.2	Boilers for Switzerland	12
3.3.3	Boilers for following countries: Germany, Austria, Czech Republic, Slovenia	13
3.3.4	Boilers for following countries: Algeria, Bulgaria, China, Finland, Greece, Ireland, Jordan, Lebanon, Morocco, Norway, Romania, Russia, Syria, Tunisia, Turkey14	
<b>4</b>	<b>Installation</b>	<b>15</b>
4.1	Regulations governing installation	15
4.1.1	In general	15
4.1.2	In particular for France:	15
4.1.3	In particular for Germany	16
4.2	Package list	16
4.3	Choice of the location	17
4.3.1	Main dimensions	17
4.3.2	Position of the boiler	18
4.3.3	Ventilation	19
4.4	Example of an installation	20
4.5	Hydraulic connections	21
4.5.1	Flushing the system	21
4.5.2	Sludge removal	21
4.5.3	Hydraulic connection of the heating circuit	21
4.5.4	Safety valve	22
4.5.5	Connection of the water circuit for domestic use	22
4.6	Chimney connection	23
4.6.1	Flue size	23
4.6.2	Connection to the flue gas pipe	23
4.7	Fuel-oil or gas connections	24
4.8	Electrical connections	24
4.9	Filling the system	24

<b>5</b>	<b>Commissioning</b> .....	<b>25</b>
<b>6</b>	<b>Switching off the boiler</b> .....	<b>25</b>
6.1	Precautions required in the case of long boiler stops .....	25
6.2	Precautions required if the heating is stopped when there is a risk of freezing .....	25
<b>7</b>	<b>Checking and maintenance</b> .....	<b>26</b>
7.1	System maintenance .....	26
7.1.1	Water level .....	26
7.1.2	Draining .....	26
7.2	Data plate .....	26
7.3	Maintenance .....	27
7.3.1	Cleaning the flue gas circuit .....	27
7.3.2	Cleaning the combustion chamber .....	27
7.3.3	Positioning of the baffle plates .....	28
7.3.4	Cleaning the flue gas box .....	29
7.3.5	Chemical sweeping .....	29
7.5	Maintenance of the burner .....	30
<b>8</b>	<b>Spare parts - GT 330</b> .....	<b>31</b>

# 1 Introduction

## 1.1 Symbols and abbreviations



### Caution danger

Risk of injury and damage to equipment. Attention must be paid to the warnings on safety of persons and equipment.



### Specific information

Information must be kept in mind to maintain comfort.



### Reference

Refer to another manual or other pages in this instruction manual.

DHW: Domestic hot water

## 1.2 General

### 1.2.1 Manufacturer's liability

Our products are manufactured in compliance with the requirements of the various applicable European Directives. They are therefore delivered with  marking and all relevant documentation.

In the interest of customers, we are continuously endeavouring to make improvements in product quality. All the specifications stated in this document are therefore subject to change without notice.

Our liability as the manufacturer may not be invoked in the following cases:

- ▶ Failure to abide by the instructions on using the appliance.
- ▶ Faulty or insufficient maintenance of the appliance.
- ▶ Failure to abide by the instructions on installing the appliance.

### 1.2.2 Installer's liability

The installer is responsible for the installation and initial start up of the appliance. The installer must respect the following instructions:

- ▶ Read and follow the instructions given in the manuals provided with the appliance.

- ▶ Carry out installation in compliance with the prevailing legislation and standards.

- ▶ Perform the initial start up and carry out any checks necessary.
- ▶ Explain the installation to the user.
- ▶ If a maintenance is necessary, warn the user of the obligation to check the appliance and maintain it in good working order.
- ▶ Give all the instruction manuals to the user.

### 1.2.3 User's liability

To ensure the optimum operation of your appliance, we strongly recommend that you abide by the following instructions:

- ▶ Read and follow the instructions given in the manuals provided with the appliance.
- ▶ Call on qualified professionals to carry out installation and initial start up.
- ▶ Get your installer to explain your installation to you.
- ▶ Have the required checks and services done.
- ▶ Keep the instruction manuals in good condition close to the appliance.

This appliance is not intended to be used by persons (including children) whose physical, sensory or mental capacity is impaired or persons with no experience or knowledge, unless they have the benefit, through the intermediary of a person responsible for their safety, of supervision or prior instructions regarding use of the appliance. Care should be taken to ensure that children do not play with the appliance.

## 1.3 Homologations

---

### 1.3.1 Certifications

---

#### ■ In general

**CE identification no: 1312 BR 46 17 (Base):**

France, Germany, Austria, Belgium, Spain, Italy, Luxemburg, Poland, Portugal, Czech Republic, Slovenia, Switzerland.

**CE identification no: 1312 BR 47 83 (Export):**

Algeria, Bulgaria, China, Finland, Greece, Ireland, Jordan, Lebanon, Morocco, Norway, Romania, Russia, Syria, Tunisia, Turkey.

#### ■ In particular for Switzerland:

**Accreditation no. OFEFP: 293010**

**Accreditation no. AEAI: 8088**

### 1.3.2 Directive 97/23/EC







---

Gas and oil boilers with a maximum operating temperature of 110°C and hot water tanks with a maximum operating pressure of 10 bar pertain to article 3.3 of the directive, and therefore, cannot be CE-marked to certify compliance with the directive 97/23 EC.



The boilers and hot water tanks are designed and manufactured in accordance with the sound engineering practice, as requested in article 3.3 of the directive 97/23/EC, it is certified by compliance with the directives 90/396/EC, 92/42/EC, 2006/95/EC and 2004/108/EC.

## 2 Safety instructions and recommendations



### 2.1 Safety instructions

-  For a proper operating of the boiler, follow carefully the instructions.
-  Only qualified professionals are authorised to work on the appliance and the installation.
-  Incorrect use or unauthorised modifications to the installation or the equipment itself invalidate any right to claim.
-  Before any work, switch off the mains supply to the appliance.
-  Keep to the polarity shown on the terminals: phase (L), neutral (N) and earth  $\frac{\perp}{\text{—}}$ .
-  Keep children away from the boiler.

#### 2.1.1 Fire hazard

-  It is forbidden to store inflammable products and materials in the boiler room or close to the boiler, even temporarily.
-  If you smell gas, do not use a naked flame, do not smoke, do not operate electrical contacts or switches (doorbell, lights, motor, lift, etc.):
  1. Shut off the gas supply.
  2. Open the windows.
  3. Extinguish all flames.
  4. Evacuate the premises.
  5. Contact a qualified professional.
  6. Inform the gas supplier.



#### 2.1.2 Risk of intoxication

-  Do not obstruct the air inlets in the room (even partially).
-  If you smell flue gases:
  1. Switch the appliance off.
  2. Open the windows.
  3. Evacuate the premises.
  4. Contact a qualified professional.

#### 2.1.3 Risk of being burnt

-  Depending on the settings of the appliance:
  - The temperature of the flue gas conduits may exceed 60°C.
  - The temperature of the radiators may reach 95°C.
  - The temperature of the domestic hot water may reach 65°C.

#### 2.1.4 Risk of damage

-  Do not stock chloride or fluoride compounds close to the appliance.
-  Install the appliance in frost-free premises.
-  Do not neglect to service the appliance: Contact a qualified professional or take out a maintenance contract for the annual servicing of the appliance.

## 2.2 Recommendations

---

- ▶ Check regularly that the installation contains water and is pressurised.
- ▶ Keep the appliance accessible at all times.
- ▶ Avoid draining the installation.
- ▶ The appliance should be on Summer or Antifreeze mode rather than switched off to guarantee the following functions:
- ▶ Anti blocking of pumps.
- ▶ Antifreeze protection.
- ▶ Protection against corrosion on domestic hot water tanks fitted with a titanium anode.



## 3 Technical description

### 3.1 General description

The boilers of the GT 330 range are pressurised hot water boilers designed for connecting to a flue pipe which require a separate automatic fuel-oil or gas burner. GT 330 boilers have the following characteristics:

- Heating body in cast iron.
- **S3, B3, K3** or **DIEMATIC-m3** control panel.
- Production of domestic hot water can be ensured by a separate hot water calorifier.

### 3.2 Composition of the range

#### 3.2.1 GT 330 S3: Boiler with basic control panel

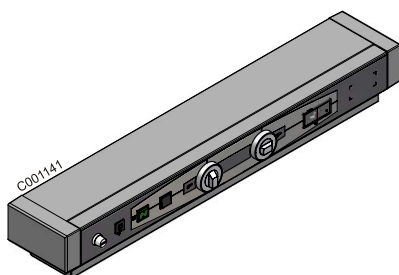

##### Standard panel to be fitted

Panel comprising the settings, control and safety devices allowing the boiler to operate autonomously, without regulation.

The standard panel is used to connect the boiler to the boiler room control cabinet.

This cabinet can be fitted with control units.

#### 3.2.2 GT 330 B3 : Boiler with electronic control panel.

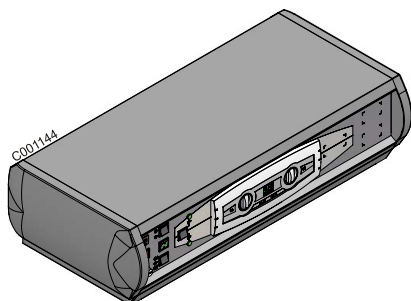

##### Separate panel

Top of the range electronic control panel with digital display, comprising the settings, control and safety devices allowing the boiler to operate autonomously.

The control panel is used to control boilers with 1 or 2-stage burners. This panel makes it possible to give priority to DHW.

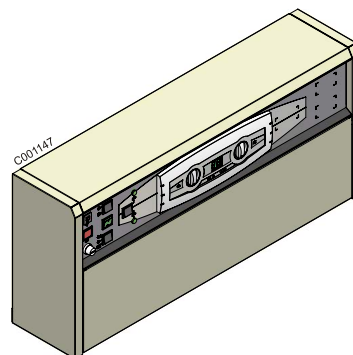

##### Side panel

A version of the B3 control panel with lateral attachment is also available.

### 3.2.3 GT 330 DIEMATIC-m3: Boiler with DIEMATIC-m3 electronic control panel

---

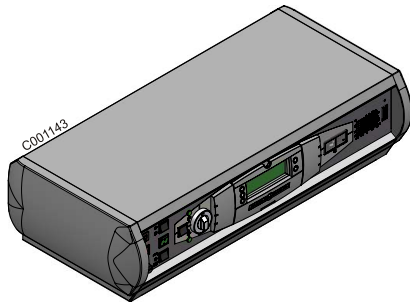

#### Separate panel

Top of the range electronic control panel with digital display, comprising the settings, control and safety devices allowing the boiler to operate autonomously.

The DIEMATIC-m3 panel is fitted as standard with a control unit which operates according to the outside temperature.

The control panel enables the operation of a boiler fitted with a 1 stage, 2 stage or modulating burner.

The DIEMATIC-m3 panel also allows the boiler to be used as a master boiler for installations with 2 to 10 boilers in cascade.

The other boilers (1 to 9) must be fitted with a "K3" control panel.

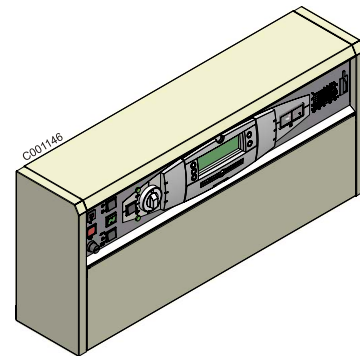

#### Side panel

A version of the DIEMATIC-m3 control panel with lateral attachment is also available.

### 3.2.4 GT 330 K3: Boiler with K3 control panel

---

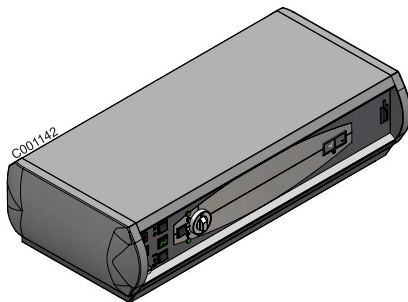

#### Separate panel

The K3 control panel is fitted only in association with a boiler fitted with a DIEMATIC-m3 control panel as part of a cascade installation (2 to 10 boilers can be connected in a cascade).

The control panel enables the operation of a boiler fitted with a 1 stage, 2 stage or modulating burner.

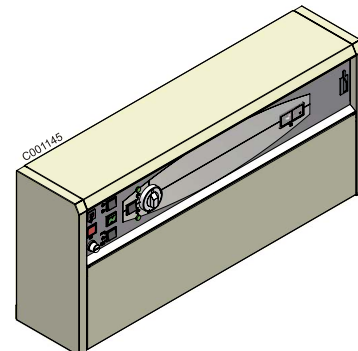

#### Side panel

A version of the K3 control panel with lateral attachment is also available.

### 3.3 Technical specifications

#### 3.3.1 Boilers for following countries: France, Belgium, Spain, Italy, Luxemburg, Poland, Portugal

**Conditions of use:**

Maximum operating temperature: 100 °C

Maximum operating pressure: 6 bar

Thermostat adjustable from 30 to 90°C

Safety thermostat: 110 °C

**Test conditions:**

 CO<sub>2</sub> Fuel oil = 13%

 CO<sub>2</sub> Natural gas = 9.5%

Ambient temperature: 20 °C

Boiler		GT 334	GT 335	GT 336	GT 337	GT 338	GT 339	
Useful output	<b>kW</b>	55-90	90-115	115-150	150-185	185-230	230-280	
Power input	<b>kW</b>	60-99	97-126	124-164	162-202	200-251	248-304	
Water content	<b>l</b>	96	116	136	156	176	196	
Number of sections		4	5	6	7	8	9	
Stand-by losses - 50 °C (A)	<b>%</b>	0.150	0.135	0.125	0.115	0.100	0.085	
Number of baffle plates		6	10	10	10	12	12	
Water resistance	Δ T = 10K (B)	<b>mbar (C)</b>	11	18	31	46	68	105
	Δ T = 15K (B)	<b>mbar (C)</b>	4.6	7.4	14.2	19.5	30.1	46
	Δ T = 20K (B)	<b>mbar (C)</b>	2.6	4.2	8	11	17	26
Flue gas temperature (B)	<b>°C</b>	< 200	< 190	< 190	< 190	< 190	< 190	
Pressure in the furnace for nozzle pressure = 0 (B) (D)	<b>mbar (C)</b>	0.2	0.4	0.7	1.2	1.8	2.2	
Mass flue gas flow rate (B)	Fuel oil	<b>Kg/h</b>	151	192	252	309	383	465
	Natural gas	<b>Kg/h</b>	159	211	277	340	422	512
Combustion chamber	Inscribed diameter	<b>mm</b>	377	377	377	377	377	377
	Length	<b>mm</b>	571	731	891	1051	1211	1371
	Volume	<b>m<sup>3</sup></b>	0.096	0.122	0.148	0.174	0.200	0.226
Maintenance consumption*	Δ T = 30K	<b>%</b>	0.150	0.135	0.125	0.115	0.100	0.085
Weight (empty)	<b>kg</b>	612	736	846	981	1103	1230	

 **In order for the boiler to operate correctly, it is imperative to respect the draught at the nozzle: 0 at the nozzle.**

\***Maintenance consumption:** total heat emission when the burner is off as a percentage of the nominal input power when the difference between the mean boiler temperature and the room temperature is 30 K.

- (A) Stand-by losses in accordance with NFD 30002 standard in % of input power.
- (B) Nominal operation (top boiler power).
- (C) 1 mbar = 10 mmWG = 10 daPa.
- (D) In no event must the draught at the nozzle exceed 0.2 mbar.

### 3.3.2 Boilers for Switzerland

**Conditions of use:**

Maximum operating temperature: 100 °C

Maximum operating pressure: 6 bar

Thermostat adjustable from 30 to 90°C

Safety thermostat: 110 °C

**Test conditions:**
CO<sub>2</sub> Fuel oil = 13%CO<sub>2</sub> Natural gas = 9.5%

Ambient temperature: 20 °C

Boiler			GT 334	GT 335	GT 336	GT 337	GT 338	GT 339
Useful output		<b>kW</b>	51-70	66-103	95-135	117-184	151-234	162-278
Power input		<b>kW</b>	55-76	71-112	102-147	126-200	162-255	173-303
Water content		<b>l</b>	96	116	136	156	176	196
Number of sections			4	5	6	7	8	9
Stand-by losses - 50 °C (A)		<b>%</b>	0.150	0.135	0.125	0.115	0.100	0.085
Number of baffle plates			6	10	10	10	12	12
Water resistance	Δ T = 10K (B)	<b>mbar (C)</b>	10	17	29	44	68	105
	Δ T = 15K (B)	<b>mbar (C)</b>	5	7	13	20	30	46
	Δ T = 20K (B)	<b>mbar (C)</b>	3	4	7	11	17	26
Flue gas temperature (C)		<b>°C</b>	< 180	< 180	< 180	< 180	< 180	< 180
Pressure in the furnace for nozzle pressure = 0 (B) (D)		<b>mbar (C)</b>	0.2	0.4	0.7	1.2	1.8	2.2
Mass flue gas flow rate (B) DIN 4705 Teil 1	Fuel oil	<b>Kg/h</b>	116	171	225	306	390	463
	Natural gas	<b>Kg/h</b>	122	180	236	321	409	486
Combustion chamber	Inscribed diameter	<b>mm</b>	377	377	377	377	377	377
	Length	<b>mm</b>	571	731	891	1051	1211	1371
	Volume	<b>m<sup>3</sup></b>	0.096	0.122	0.148	0.174	0.200	0.226
Maintenance consumption*	Δ T = 30K	<b>%</b>	0.150	0.135	0.125	0.115	0.100	0.085
Weight (empty)		<b>kg</b>	612	736	846	981	1103	1230

 **In order for the boiler to operate correctly, it is imperative to respect the draught at the nozzle: 0 at the nozzle.**

- (A) Standby consumption LVR 92  
(Boiler temperature: 70 °C)
- (B) Nominal operation (top boiler power).
- (C) 1 mbar = 10 mmWG = 10 daPa.
- (D) In no event must the draught at the nozzle exceed 0.2 mbar.

### 3.3.3 Boilers for following countries: Germany, Austria, Czech Republic, Slovenia

**Conditions of use:**

Maximum operating temperature: 100 °C

Maximum operating pressure: 6 bar

Thermostat adjustable from 30 to 90°C

Safety thermostat: 110 °C

**Test conditions:**

 CO<sub>2</sub> Fuel oil = 13%

 CO<sub>2</sub> Natural gas = 9.5%

Ambient temperature: 20 °C

Boiler			GT 334	GT 335	GT 336	GT 337	GT 338	GT 339
Useful output	<b>kW</b>		55-80	80-110	110-140	140-175	175-210	210-250
Power input	<b>kW</b>		60-87	86-120	119-153	151-190	188-228	226-271
Water content	<b>l</b>		96	116	136	156	176	196
Number of sections			4	5	6	7	8	9
Number of baffle plates			6	10	10	10	12	12
Maintenance consumption (A)	Δ T = 30K	%	0.150	0.135	0.125	0.115	0.100	0.085
Water resistance	Δ T = 10K (C)	<b>mbar (B)</b>	8.7	16.5	27	41.2	56.9	84
	Δ T = 20K (C)	<b>mbar (B)</b>	2.1	3.8	7	9.6	14.2	20.8
Flue gas temperature (C)		°C	< 180	< 180	< 180	< 180	< 180	< 180
Pressure in the furnace for nozzle pressure = 0 (C) (D)		<b>Pa (B)</b>	20	35	60	110	150	200
Mass flue gas flow rate (C) DIN 4705 Teil 1	Fuel oil	<b>kg per sec</b>	0.037	0.051	0.065	0.081	0.097	0.115
	Natural gas	<b>kg per sec</b>	0.039	0.054	0.068	0.085	0.102	0.121
Combustion chamber	Inscribed diameter	<b>mm</b>	377	377	377	377	377	377
	Length	<b>mm</b>	571	731	891	1051	1211	1371
	Volume	<b>m<sup>3</sup></b>	0.096	0.122	0.148	0.174	0.200	0.226
Weight (empty)		<b>kg</b>	612	736	846	981	1103	1230

 **In order for the boiler to operate correctly, it is imperative to respect the draught at the nozzle: 0 at the nozzle.**

- (A) Standby consumption LVR 92  
(Boiler temperature: 70 °C)
- (B) 1 mbar = 10 mmWG = 10 daPa.
- (C) Nominal operation (top boiler power).
- (D) In no event must the draught at the nozzle exceed 0.2 mbar.

### 3.3.4 Boilers for following countries: Algeria, Bulgaria, China, Finland, Greece, Ireland, Jordan, Lebanon, Morocco, Norway, Romania, Russia, Syria, Tunisia, Turkey

**Conditions of use:**

Maximum operating temperature: 100 °C

Maximum operating pressure: 6 bar

Thermostat adjustable from 30 to 90°C

Safety thermostat: 110 °C

**Test conditions:**CO<sub>2</sub> Fuel oil = 13%CO<sub>2</sub> Natural gas = 9.5%

Ambient temperature: 20 °C

Boiler			GT 334	GT 335	GT 336	GT 337	GT 338	GT 339
Useful output		kW	70-105	105-140	140-180	180-230	230-280	280-330
Power input		kW	76-117	115-156	153-199	197-253	252-309	305-361
Water content		l	96	116	136	156	176	196
Number of sections			4	5	6	7	8	9
Stand-by losses - 50 °C (A)		%	0.17	0.14	0.13	0.11	0.10	0.09
Number of baffle plates			6	10	10	6	6	6
Water resistance	Δ T = 15K	mbar (B)	6.2	10.9	20.4	30	44.5	63.8
Flue gas temperature (C)		°C	210	210	210	210	210	210
Pressure in the furnace for nozzle pressure = 0 (C) (D)		mbar (B)	0.3	0.6	1.1	1.6	2.2	2.5
Mass flue gas flow rate (C)	Fuel oil	Kg/h	178	238	306	391	475	560
	Natural gas	Kg/h	187	250	321	410	499	588
Flue gas circuit volume (Flue ways + Combustion chamber)		m <sup>3</sup>	0.163	0.206	0.249	0.292	0.335	0.378
Combustion chamber	Inscribed diameter	mm	377	377	377	377	377	377
	Length	mm	571	731	891	1051	1211	1371
	Volume	m <sup>3</sup>	0.096	0.122	0.148	0.174	0.200	0.226
Weight (empty)		kg	612	736	846	981	1103	1230

 **In order for the boiler to operate correctly, it is imperative to respect the draught at the nozzle: 0 at the nozzle.**

- (A) Stand-by losses in accordance with prevailing standard
- (B) 1 mbar = 10 mmWG = 10 daPa
- (C) Nominal operation (top boiler power)
- (D) In no event must the draught at the nozzle exceed 0.2 mbar.

# 4 Installation

## 4.1 Regulations governing installation

### 4.1.1 In general

 Installation must be carried out in accordance with the prevailing regulations, the codes of practice and the recommendations in these instructions.

### 4.1.2 In particular for France:

Heating installations must be designed and constructed in such a way as to prevent the return of water from the heating circuit and products put into it into the drinking water network located upstream. The installation must not be in direct relation with the drinking water network (Article 16-7 of the departmental health Directive).

When these installations are fitted with a filling system connected to the drinking water network, they comprise a CB disconnecter (disconnecter for zones with non-controllable pressure differences) which satisfy the functional requirements of the NF P 43-011 standard.

#### ■ Residential buildings

##### Statutory terms and conditions of installation and maintenance:

The installation and maintenance of the appliance must be carried out by a qualified professional in compliance with the statutory texts of the codes of conduct in force, particularly:

- Order of 27 April 2009 amending the Order of 2 August 1977 Technical and safety rules applicable to combustible gas and liquefied hydrocarbon installations situated inside residential buildings and their annexes.
- NF P 45-204 standards Gas installation, (formerly DTU 61-1, gas installations: April 1982, addendum no 1: July 1984).
- Local Sanitary Regulations

For appliances connected to the electricity network:

- NF C 15-100 standards Low voltage electrical installation - Rules..

#### ■ Establishments open to the public

##### Statutory terms and conditions of installation:

The installation and maintenance of the appliance must be carried out in compliance with the statutory texts and rules of the codes of conduct in force, particularly:

- Safety regulations against fire and panic in establishments open to the public:

##### a. General regulations

For all appliances:

- Articles GZ - Installations operating on combustible gases and liquefied hydrocarbons.

Then, depending on use:

- Articles CH-Heating, ventilation, refrigeration, air conditioning and production of steam and domestic hot water.
- b. Instructions specific to each type of establishment open to the public (hospitals, stores, etc.).

#### ■ Certificate of compliance (only concerns GT 330 boilers fitted with a gas burner)

In application of Article 25 of the Order of 27 April 2009 amending the Order of 2 August 1977 amended and Article 1 of the amended Order of 05/02/1999, the installer is required to draw up certificates of conformity approved by the Ministers responsible for construction and gas safety:

- Different forms (forms 1, 2 or 3) for a new gas installation.
- Model 4 in particular after replacing a furnace with a new one.

### 4.1.3 In particular for Germany

---

Abide by the following standards, rules and directives when installing and commissioning the boiler:

- DIN 4705: calculation of chimney dimensions.
- DIN EN 12828 (June 2003 edition): heating systems in buildings. Planning of hot water heating installations (up to a maximum operating temperature of 105°C and a maximum output of 1 MW).
- DIN 4753: drinking and industrial water heating installations.
- DIN 1988: technical rules on drinking water installations (TRW).
- DVGW-TRGI: technical rules on gas installations, including complementary equipment.
- Working paper DVGW G 260/I: technical rules on the nature of the gas.

## 4.2 Package list

---



See assembly instructions.



### 4.3 Choice of the location

#### 4.3.1 Main dimensions

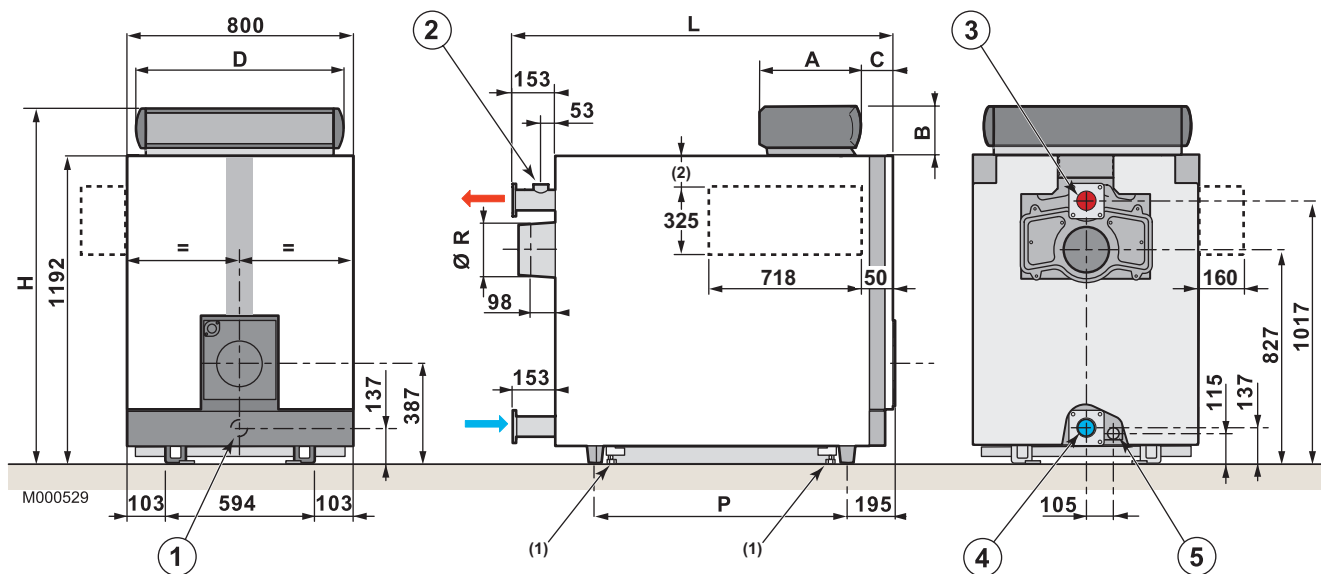

- ① Sludge removal hole  $\varnothing$  Rp 2 1/2 (plugged)
- ② Rp 1 1/2 socket for the safety control unit
- ③ Heating flow (Flange + Counter flange with collar to be welded) orifice  $\varnothing$  2" 1/2 (Option:  $\varnothing$  2")
- ④ Heating return (Flange + Counter flange with collar to be welded) orifice  $\varnothing$  2" 1/2 (Option:  $\varnothing$  2")
- ⑤ Rp 1 1/2 draining outlet (plugged)

- Mk Tapped connection
- (1) Adjustable feet: Basic dimension 0 mm, adjustment possible: 0 to 40 mm
- (2) The lateral control panel can be mounted to the right or left of the boiler. Exact height positioning defined by the fitter during assembly.

Boiler	GT...	GT 334	GT 335	GT 336	GT 337	GT 338	GT 339
Standard panel	A	130	130	130	130	130	130
	B	105	105	105	105	105	105
	C	165	165	165	165	165	165
	D	738	738	738	738	738	738
	H	1297	1297	1297	1297	1297	1297
Table K3 + DIEMATIC-m3 + B3	A	355	355	355	355	355	355
	B	195	195	195	195	195	195
	C	145	145	145	145	145	145
	D	755	755	755	755	755	755
	H	1387	1387	1387	1387	1387	1387
L (mm)		991	1151	1311	1471	1631	1791
P (mm)		490	650	810	970	1130	1290
R (mm)		180	180	180	200	200	200

### 4.3.2 Position of the boiler

For the assembly and because of their design, GT 330 boilers require no special base. Their closed furnace system means that the floor need not have refractory properties. All you have to ensure is that the floor can support the weight of the boiler when it is fitted for operation.

If the boiler location is not determined precisely, leave enough space around the boiler to facilitate monitoring and maintenance operations.

The dimensions (in mm) correspond to the minimum recommended dimensions needed to ensure adequate accessibility around the boiler.

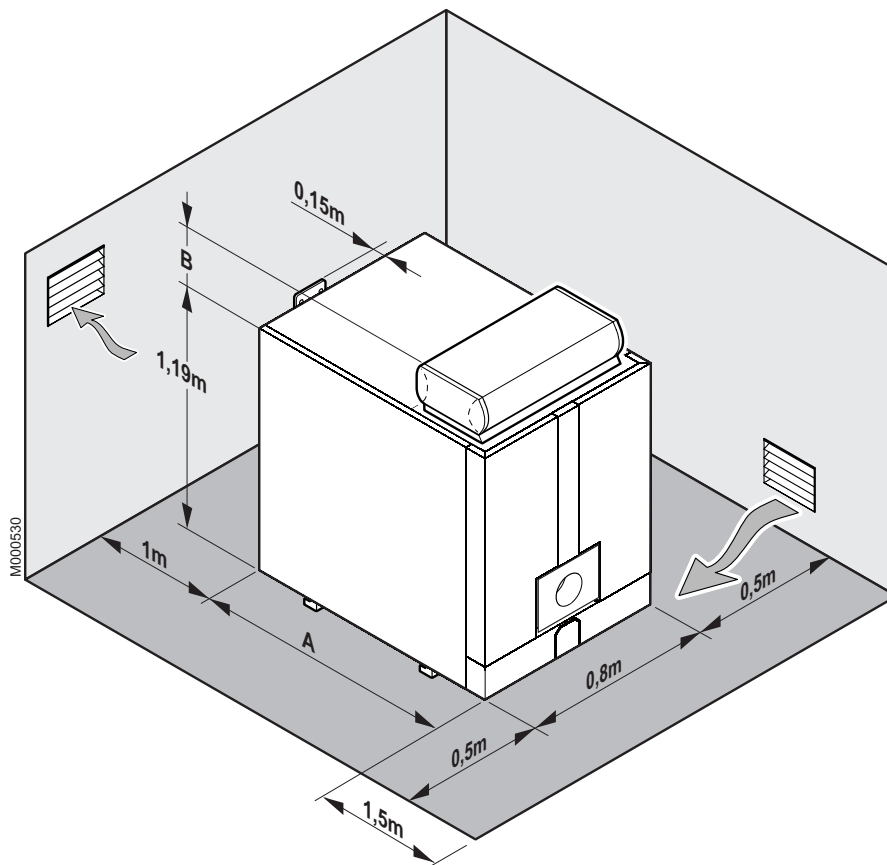

Boiler		GT 334	GT 335	GT 336	GT 337	GT 338	GT 339
Size A	mm	840	1000	1160	1320	1480	1640
B	Standard panel	mm	105	105	105	105	105
	K3 control panel	mm	195	195	195	195	195
	B3 DIEMATIC-m3						

**⚠ Pay attention to the overall volume of the burner when the door is open. To install several boilers in cascade, these dimensions should be adapted accordingly.**

### 4.3.3 Ventilation

To allow the input of combustive air, sufficient ventilation must be provided in the boiler room, for which the cross section and emplacement must satisfy regulations in force in the country in which the boiler is installed.

Position the air inlets in relation to the high ventilation vents in order that the air is refreshed throughout the boiler room.

 **Do not obstruct the air inlets in the room (even partially).**

 **In order to avoid damage to the boiler, it is necessary to prevent the contamination of combustion air by chlorine and/or fluoride compounds, which are particularly corrosive.**

These compounds are present, for example, in aerosol sprays, paints, solvents, cleaning products, washing products, detergents, glues, snow clearing salts, etc.

Therefore:

- Do not pull in air evacuated from premises using such products: hairdressing salons, dry cleaners, industrial premises (solvents), premises containing refrigeration systems (risk of refrigerant leakage), etc.
- Do not stock such products close to the boilers.

**If the boiler and/or peripheral equipment are corroded by such chloride or fluoride compounds, the contractual guarantee cannot be applied.**

#### France

The minimum cross sections and the emplacement of the fresh air inlet and the air discharge are governed by the order of 21/03/1968 amended by the orders of 26/02/1974 and 03/03/1976.

#### ■ Generator installed in a building for collective use (installations less than 70 kW)

- ▶ The fresh air inlet must:
  - Come out in the lower section of the premises,
  - Have a free minimum cross section calculated on the basis of 0.03 dm<sup>2</sup> per kilowatt installed output and at least equal to 2.5 dm<sup>2</sup>.
- ▶ The air discharge must:
  - Be located in the upper section of the premises,
  - Rise above the roof (unless using an equivalent system which does not cause a nuisance to neighbours),
  - Have a free cross section (corresponding to 2/3 of that of the air inlet and at least equal to 2.5 dm<sup>2</sup>).

#### ■ Generator installed in a building for individual use

- ▶ An adequate supply of fresh air must be provided as close as possible to the appliances. Its cross section must be at least 0.5 dm<sup>2</sup>.
- ▶ In the upper section of the premises, an air outlet must ensure effective ventilation.

#### ■ Establishments open to the public

- ▶ New establishment: Refer to the order of 25/06/1980 (installations of more than 20 kW and less than or equal to 70 kW).
- ▶ Existing establishment: Refer to the order of 25/06/1980 (installations less than 70 kW).

## 4.4 Example of an installation

The example of an installation shown below does not cover every possible configuration. Its sole aim is to draw your attention to the basic rules to be respected.

**GT 330 boiler with domestic hot water production using an independent tank**

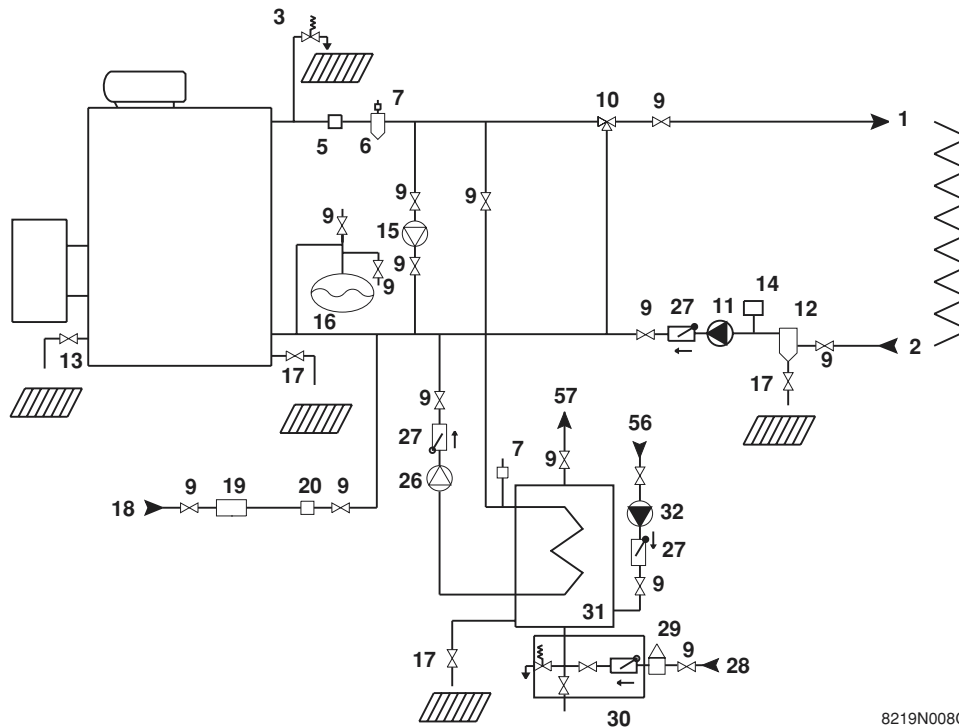

8219N008C

- |   |  |
|---|--|
| <ul style="list-style-type: none"> <li>1 Heating flow</li> <li>2 Heating return</li> <li>3 3-bar safety valve + Pressure gauge</li> <li>5 Flow switch</li> <li>6 Air separator</li> <li>7 Automatic air vent</li> <li>9 Isolating valve</li> <li>10 3-way mixing valve</li> <li>11 Boiler pump</li> <li>12 Sludge decanting pot (particularly recommended on older installations)</li> <li>13 Flush valve</li> <li>14 Water low safety pressure-sensitive switch</li> <li>15 Shunt pump</li> <li>16 Expansion vessel</li> </ul> | <ul style="list-style-type: none"> <li>17 Drain cock</li> <li>18 Heating circuit filling (with disconnecter depending on prevailing regulations)</li> <li>19 Water treatment</li> <li>20 Water meter</li> <li>26 DHW load pump</li> <li>27 Non-return valve</li> <li>28 Domestic cold water inlet</li> <li>29 Pressure reducer (if mains pressure &gt; 5.5 bar)</li> <li>30 Safety unit calibrated to 7 bar with indicator type discharge</li> <li>31 Independent domestic hot water tanks</li> <li>32 Domestic hot water loop pump (optional)</li> <li>56 Domestic hot water circulation loop return</li> <li>57 Domestic hot water outlet</li> </ul> |
|---|--|

## 4.5 Hydraulic connections

### 4.5.1 Flushing the system

#### ■ Installing the boiler in new installations (installations less than 6 months old)

- ▶ Clean the installation with a universal cleaner to eliminate debris from the appliance (copper, hemp, flux).
- ▶ Thoroughly flush the installation until the water runs clear and shows no impurities.

#### ■ Installing the boiler in existing installations

- ▶ Remove sludge from the installation.
- ▶  See: Sludge removal.
- ▶ Flush the installation.
- ▶ Clean the installation with a universal cleaner to eliminate debris from the appliance (copper, hemp, flux).
- ▶ Thoroughly flush the installation until the water runs clear and shows no impurities.

### 4.5.2 Sludge removal

A tapped Rp 2" 1/2 hole with a plug has been provided on the bottom of the front of the boiler. Fit a 1/4 turn valve (not supplied) on the opening to remove the sludge.

Sludge removal leads to the draining of large quantities of water, so remember to refill the system after the operation.

After this operation, go ahead and fill the installation.

 See: Filling the system.

**i** never replace a boiler in an existing system without carefully rinsing the system first. Install a sludge decanting pot on the return pipe, very close to the boiler.

### 4.5.3 Hydraulic connection of the heating circuit

#### ■ Water flow in the boiler

The water flow in the boiler when the burner is operating must correspond with the following formulae:

- Nominal water flow  $Q_n = 0.86 P_n/20$
- Minimum flow  $Q_{min} = 0.86 P_n/45$  (this flow also corresponds with the minimum recycle flow in the boiler)
- Maximum water flow  $Q_{max} = 0.86 P_n/5$

$Q_n$  = flow in m<sup>3</sup>/h

$P_n$  = Nominal output (full boiler output) in kW.

#### ■ Operation in cascade

After stopping the burner:

- Timeout required before the order to close a 2 way valve: 3 min.
- Switch a possible shunt pump (located between the boiler and a butterfly valve) off via the end of run contact of the butterfly valve.

#### ■ Operation with 2-stage burner

- The water temperature in the boiler is maintained at 50°C or more; The first stage must be set to a minimum of 30% of the nominal stage.
- Operation at modulated low temperature (minimum outlet temperature: 30°C); The first stage must be set to a minimum of 50% of the nominal stage.

#### ■ Operation with modulating burner

- The water temperature in the boiler is maintained at 50°C or more; The burner can modulate down to 30% of the nominal stage.

- Operation at modulated low temperature (minimum outlet temperature: 30°C); The burner can modulate down to 50% of the nominal stage.

### 4.5.4 Safety valve

The safety valve must be connected to the boiler outlet and no other valve or flap must be interposed between it and the boiler.

#### ■ Minimum safety valve flowrate as a function of maximum boiler nominal output

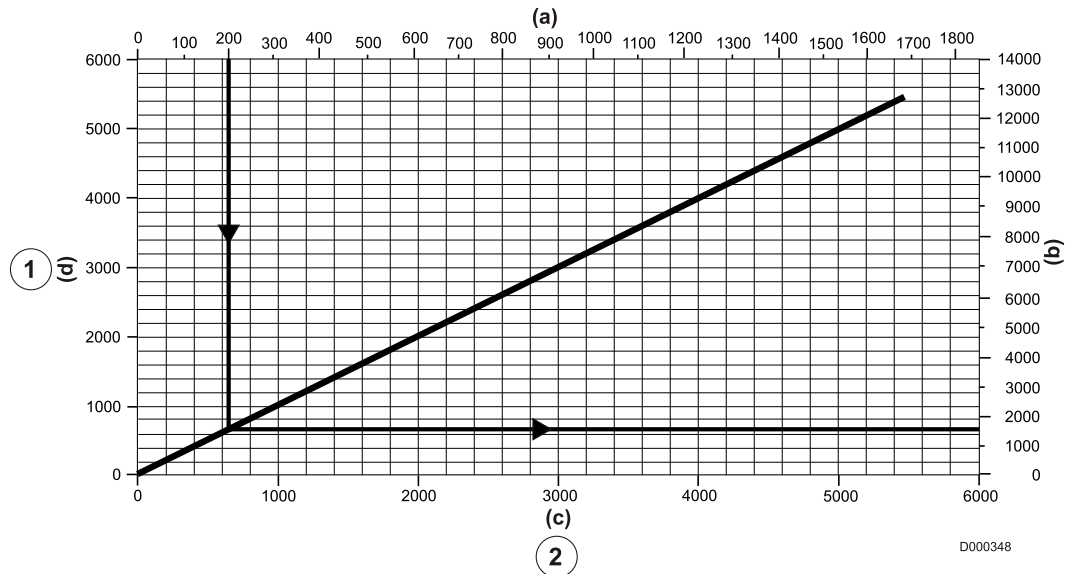

- ① Minimum relieving capacity
  - ② Maximum gross boiler output
- Unit (a) = kW  
 (b) = lb/h  
 (c) = MBtu/h  
 (d) = Kg/h

#### Example

Maximum boiler nominal output is 200 kW.

Minimum safety valve flowrate must be 700 Kg/h.

### 4.5.5 Connection of the water circuit for domestic use

 See: Domestic hot water calorifier instructions.

## 4.6 Chimney connection

The high-performance features of modern boilers and their use in specific conditions as a result of the advance in burner technology (e.g. first-stage or low modulation range operation) lead to very low flue gas temperatures (<160°C):

For this reason:

- Use flue gas pipes designed to enable the flow of condensates which may result from such operating modes in order to prevent damage to the chimney.
- Install a draining tee at the bottom of the chimney.

The use of a draught moderator is recommended as well.

- As a last resort (old, outside, badly insulated chimney), the baffle plates in the 4 upper flue ways can be partially removed, resulting in an increase in the flue gas temperature.

### 4.6.1 Flue size

**France:** Refer to applicable regulations while determining the size of the flue.

Please note that GT 330 boilers have pressurised and tight furnaces and that the pressure at the connection to the chimney must not exceed 0 mbar, unless special sealing precautions have been taken, for instance in order to connect a static condenser/regenerator.

 **In order for the boiler to operate correctly, it is imperative to respect the draught at the nozzle (= 0).**

### 4.6.2 Connection to the flue gas pipe

The connection shall be removable, and offer minimum load losses, i.e. it must be as short as possible with no sudden change in section.

Its diameter shall always be at least equal to that of the boiler outlet, i.e.:

- Ø 180 mm: for 4 to 6 sections
- Ø 200 mm: for 7 to 9 sections

Fit a measuring point (Ø 10 mm hole) on the flue, in order to adjust the burner (combustion check).

## 4.7 Fuel-oil or gas connections

 Refer to the instructions supplied with the burner.

 **The burner head deflector must be flush with the insulation of the burner door.**

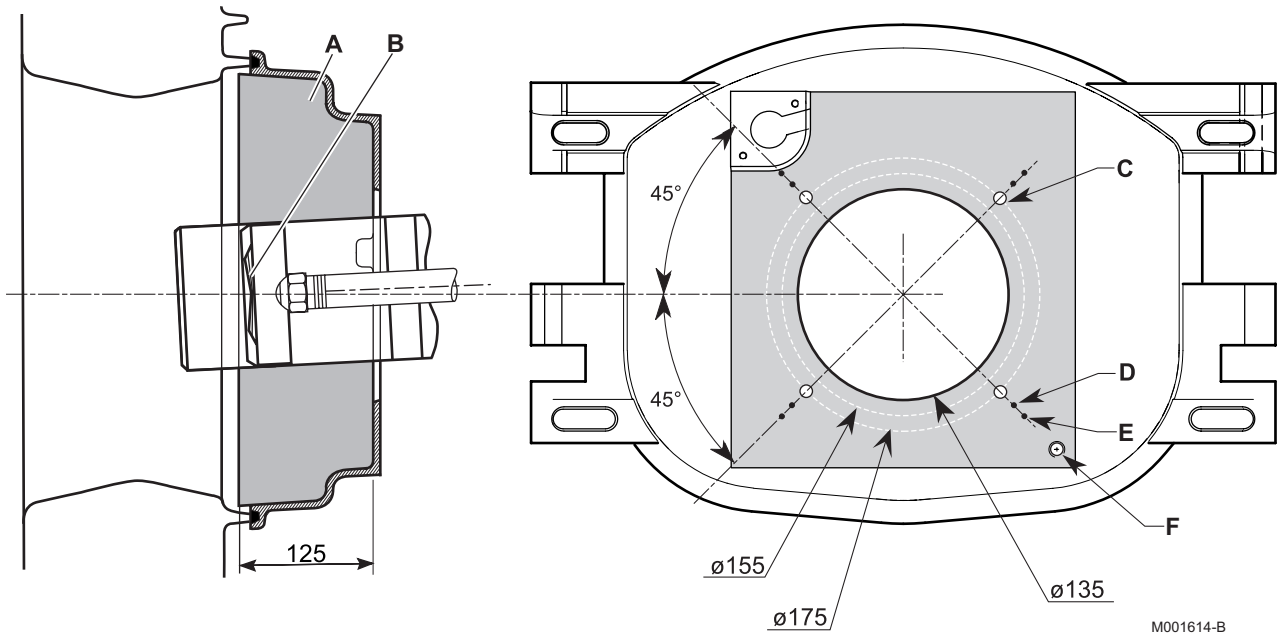

- A Furnace door insulation
- B Turbulator
- C 4 markings on Ø 170

- D 4 markings on Ø 200
- E 4 markings on Ø 220
- F Pressure gauge measurement socket

## 4.8 Electrical connections

 Refer to the connection instructions supplied with the control panel..

## 4.9 Filling the system

Filling shall be performed with a low flow rate from a low point in the boiler room in order to ensure that all the air in the boiler is bled from the high point of the system.

All the pumps must be stopped before filling (included shunt pump(s)).

 **Do not add cold water suddenly into the boiler when it is hot.**

 **VERY IMPORTANT: Instructions for starting up the boiler for the first time after the system is fully or partly drained: If all the air is not bled naturally to an expansion vessel which opens out onto the air, the system must include manual bleeder valves, in addition to automatic bleeder valves with the capability to bleed the system by themselves when it is operating, the manual bleeder valves are used to bleed all the high points of the system and to make sure that the filled system is free of air before the burner is turned on.**



## 5 Commissioning



See:

- Control panel instructions
- Burner instructions
- Domestic hot water calorifier instructions

## 6 Switching off the boiler

- ▶ Set the On/Off switch to **O**.



See: Control panel instructions.

- ▶ Cut the gas supply to the boiler (if present).

### ■ DIEMATIC-m3 control panel



**The panel must always be supplied with 230V voltage:**

- to ensure the anti-grip of the heating pump,
- to ensure Titan Active System® operation when a titanium anode is protecting the DHW tank.

Use the mode:

- summer to shut down the heating.
- antifreeze to shut down the boiler if you are to be absent.

### 6.1 Precautions required in the case of long boiler stops

- The boiler and the chimney must be swept carefully.
- Close all the doors of the boiler to prevent air from circulating inside the boiler.
- We advise removing the pipe which connects the boiler to the chimney and to close off the nozzle with a cover.

### 6.2 Precautions required if the heating is stopped when there is a risk of freezing

We recommend the use of a correctly dosed antifreeze agent to prevent to the heating circuit from freezing.

If this cannot be done, drain the system completely.

# 7 Checking and maintenance

## 7.1 System maintenance

### 7.1.1 Water level

Regularly check the level of water in the system and top up if required, taking care that cold water is not added suddenly into the boiler when it is hot.

The use of an automatic filling is strongly discouraged.

This operation should be required only a few times in each heating season, with very low quantities of water; otherwise, look for the leak and repair it.

### 7.1.2 Draining

**⚠ We advise you against draining the system unless it is absolutely necessary.**

For example: Several months' absence with the risk of ice in the building.

## 7.2 Data plate

The rating plate fixed on the side of the boiler during installation is used to identify the boiler correctly and also provides the main specifications of the boiler.

- ① Boiler type
- ② Manufacturing date
- ③ Year of manufacture
- ④ Week of manufacture
- ⑤ Serial no. of the appliance

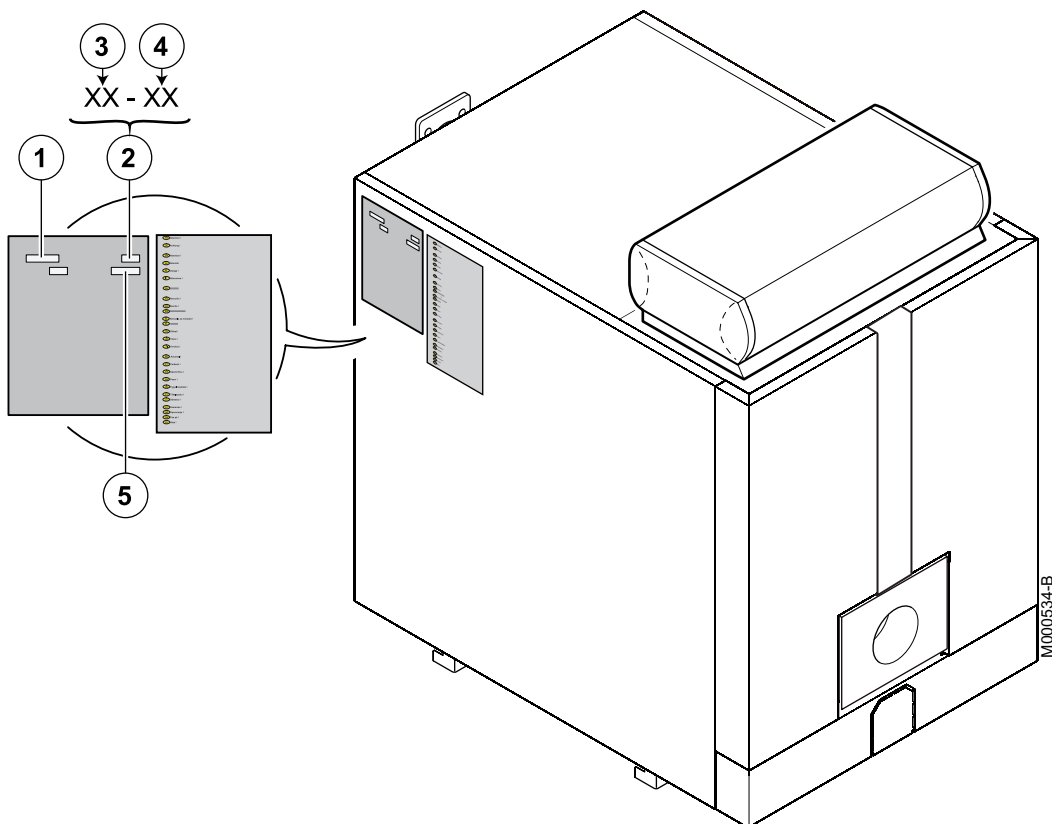

## 7.3 Maintenance

**!** The boiler will only operate efficiently if the exchange surfaces are kept clean.

The boiler must be cleaned as often as necessary and, like the chimney, **at least once a year** or more in accordance with the prevailing regulations and the insurance contract taken out.

**!** The operations described below shall only be performed with the boiler and power supply off.

### 7.3.1 Cleaning the flue gas circuit

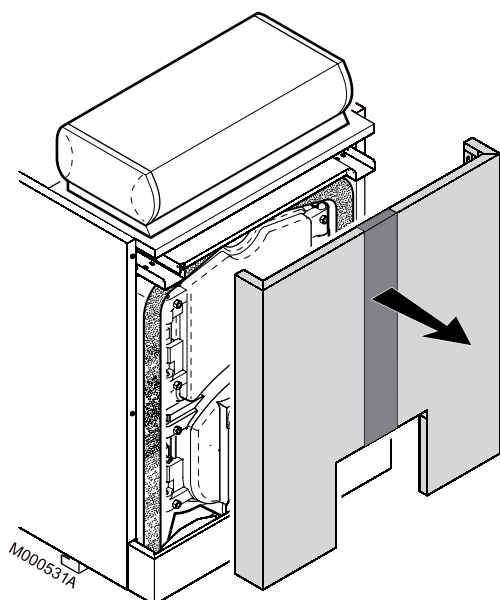

- Unhook the front panel.
- Open the cleaning door (top door) by unscrewing the 4 closing nuts (17 mm spanner).
- Remove the baffle plates.
- Carefully sweep the flue ways with the brush supplied for that purpose.
- Also sweep the baffle plates and the front panel.
- If possible, use a vacuum cleaner.
- Replace the baffle plates.
- Close the door.

### 7.3.2 Cleaning the combustion chamber

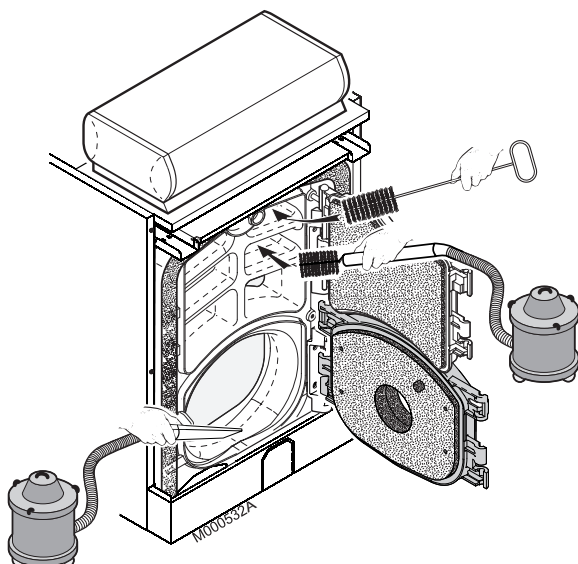

- Unscrew the 4 closing nuts and open the furnace door.
- Brush out the inside of the furnace.
- Use a vacuum cleaner to remove any soot which has accumulated in the combustion chamber.
- Close the door and replace the front panel.

### 7.3.3 Positioning of the baffle plates

**!** The first two baffle plates in the 2 lower flue ways are fitted with stops allowing them to be positioned in the required emplacement.

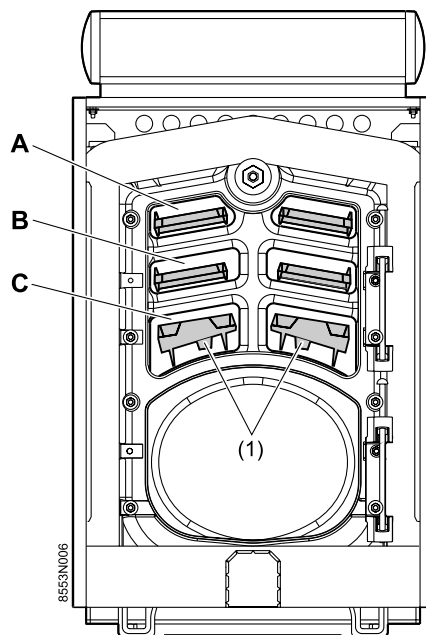

(1) Stop

■ Boilers for following countries: France, Germany, Austria, Belgium, Spain, Italy, Luxemburg, Poland, Portugal, Slovenia, Czech Republic, Switzerland

Baffles		Flue ways	GT 334	GT 335	GT 336	GT 337	GT 338	GT 339
Upper	Length: 410 mm	A + B	-	8	8	4	-	-
	Length: 570 mm	A + B	4	-	-	4	8	8
Lower	Length : 412 mm	C	2	2	2	2	4	2
	Length: 572 mm	C	-	-	-	-	-	2

■ Boilers for following countries: Algeria, Bulgaria, China, Finland, Greece, Ireland, Jordan, Lebanon, Morocco, Norway, Romania, Russia, Syria, Tunisia, Turkey

Baffles		Flue ways	GT 334	GT 335	GT 336	GT 337	GT 338	GT 339
Upper	Length: 410 mm	A + B	-	8	8	-	-	-
	Length: 570 mm	A + B	4	-	-	4	4	4
Lower	Length : 412 mm	C	2	2	2	2	2	2

### 7.3.4 Cleaning the flue gas box

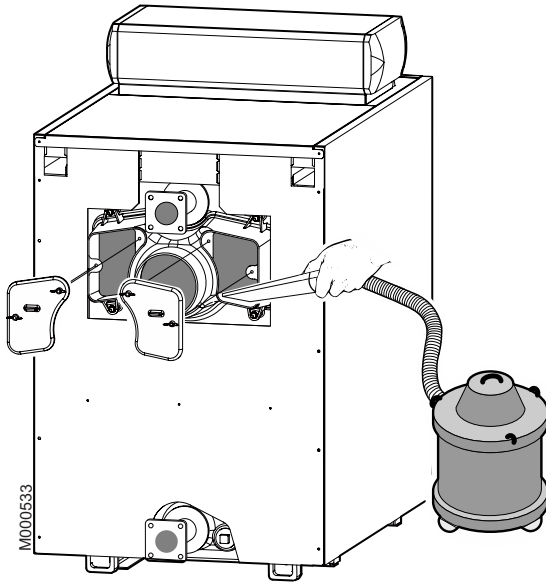

- Remove the left and right cleaning hatches from the flue gas box (2 butterfly screws) and use a vacuum cleaner to remove any soot which has accumulated.
- Replace the cleaning hatches.

### 7.3.5 Chemical sweeping

#### ■ General principle

Boilers are traditionally swept mechanically. There are now chemical sweeping methods which facilitate this maintenance work.

A chemical reagent is applied to the boiler's heating surfaces.

After application, the reaction is completed by igniting the burner. The initial deposits are neutralised and pyrolised. The remaining pulverent residues are easy to remove by sweeping or vacuum cleaning.

#### ■ The products

The product must be suitable for boilers with a cast iron body. Various manufacturers offer products in the form of a concentrated liquid or aerosol.

The aerosols are packaged in 0.5 to 1 l spray cans for treating domestic boilers. Refer to the instructions supplied with the product.

The liquid products are available in 1 to 50 l containers. These concentrated liquids are diluted before application with a spray.

Sprays exist in various forms suitable for their intended use:

- Low capacity (2 or 3 l) spray with built-in reservoir for small boilers and moderate frequency. Manual pressurisation of the reservoir.
- 5 l spray with separate reservoir, nozzle and connecting tube. The nozzles enable easy application at the back of the combustion chamber. Manual pressurisation of the reservoir.
- Motor-assisted pressurisation spray with reservoir, nozzle and connecting tube. These sprays are intended for intensive use.

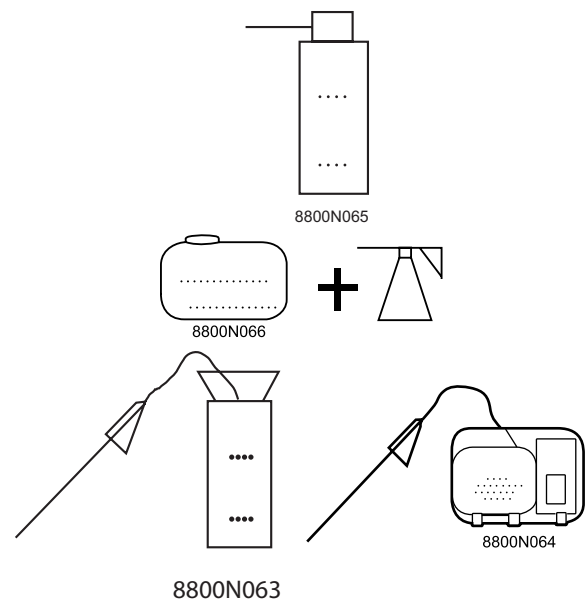

### ■ Operational mode

The operating mode mentioned corresponds to standard user situations. Refer to the manufacturer's instructions for specific advice on the product used.

### ■ Application

- Depending on the product, the boiler must be cold or heated. Refer to the instructions supplied with the product.
- Direct application to the heating surfaces with aerosol sprays.
- The concentrates are diluted in the proportions 1/5 to 1/20 (depending on the product and the condition of the boiler).
- Application with the spray is done in the upper part of the boiler and on the walls of the combustion chamber. Surfaces are dampened but not washed. It is not necessary to use the spray to get between the heating surfaces.
- A volume of one litre of solution is generally used for 1 m<sup>2</sup> of heating surface (domestic boiler), i.e. 0.05 to 0.2 l of concentrate.

### ■ Ignition

The burner is ignited after allowing the product time to penetrate for 2 to 5 min. Refer to the instructions supplied with the product.

### ■ Cleaning

- Remove the baffle plates.
- Light sweeping will remove the pulverent residues remaining after combustion.  
The remaining pulverent residues are easy to remove by sweeping or vacuum cleaning.  
For certain products, brief application after cleaning has a preventive effect, limiting deposits on the heating surfaces.
- Replace the baffle plates.
- Close the door of the combustion chamber.
- Service the burner.
- Replace the front panel.

## 7.4 Cleaning the casing material

---

Use a soapy solution and a sponge only. Rinse with clean water and dry with chamois leather or a soft cloth.

## 7.5 Maintenance of the burner

---

 Refer to the instructions supplied with the burner.

# 8 Spare parts - GT 330



To order a spare part, quote the reference number next to the part required.

300007650-002-C

## Boiler body

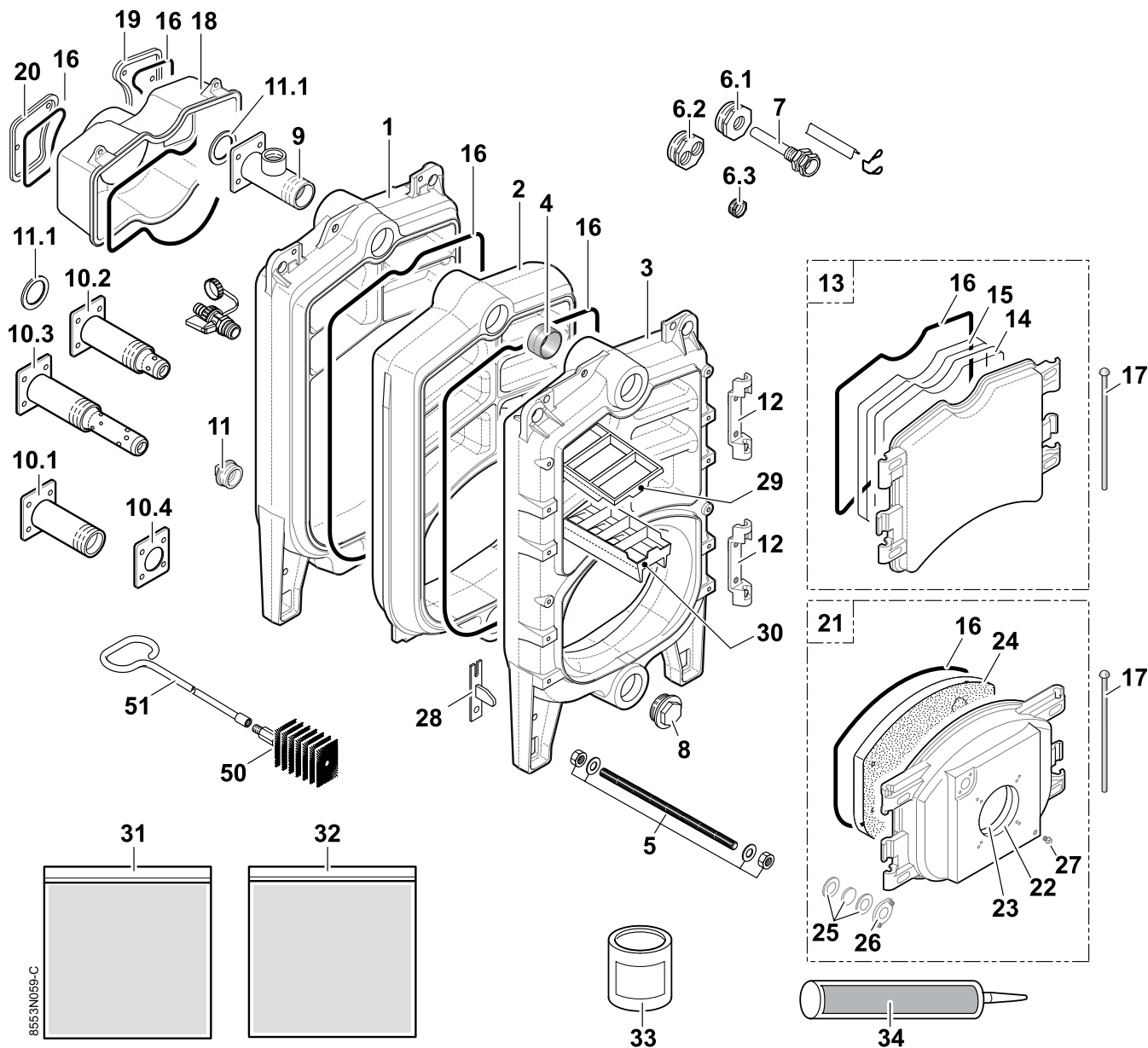

8553N059-C

DE DIETRICH THERMIQUE S.A.S. - Spare parts centre

4 rue d'Oberbronn - F-67110 REICHSHOFFEN - ☎ +33 (0)3 88 80 26 50 - 📠 +33 (0)3 88 80 26 98

cpr@dedietrichthermique.com

### Insulation

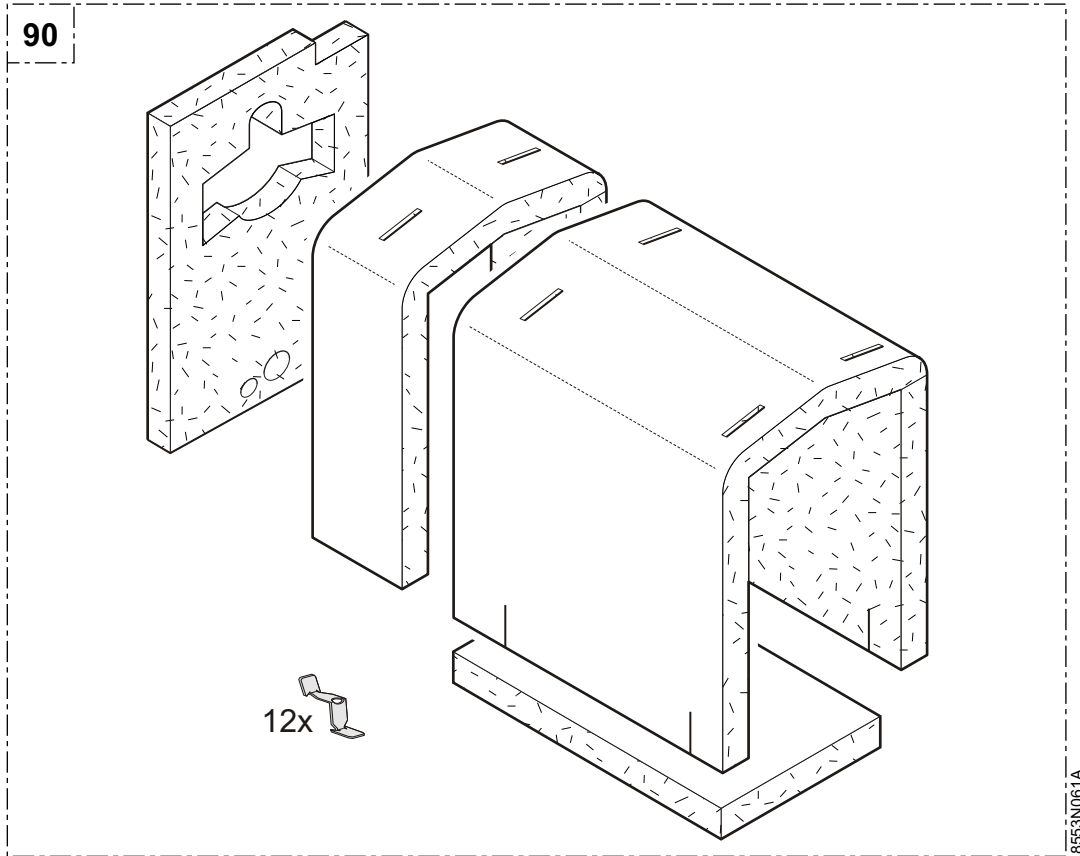

### Base frame

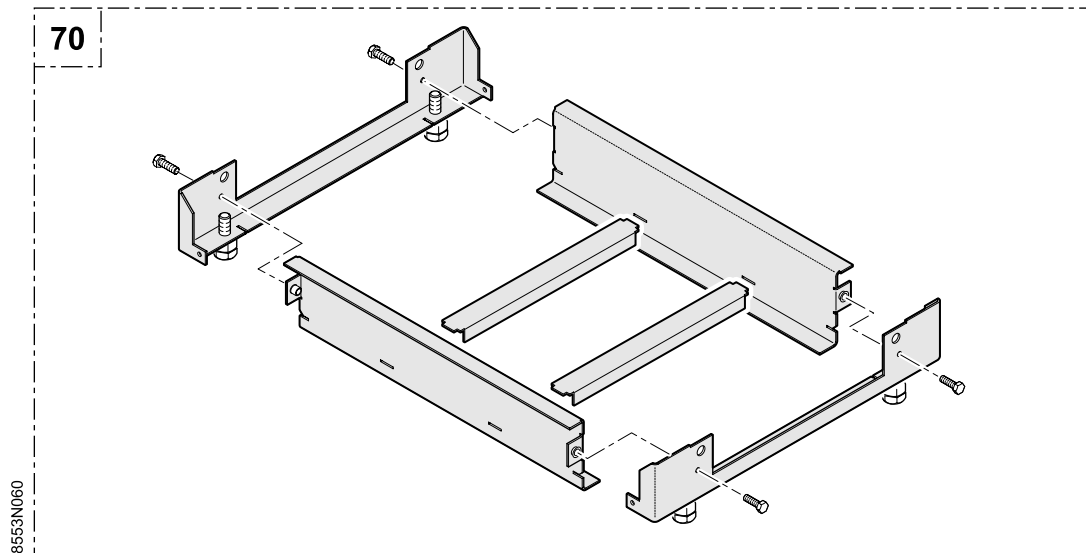



## Casing

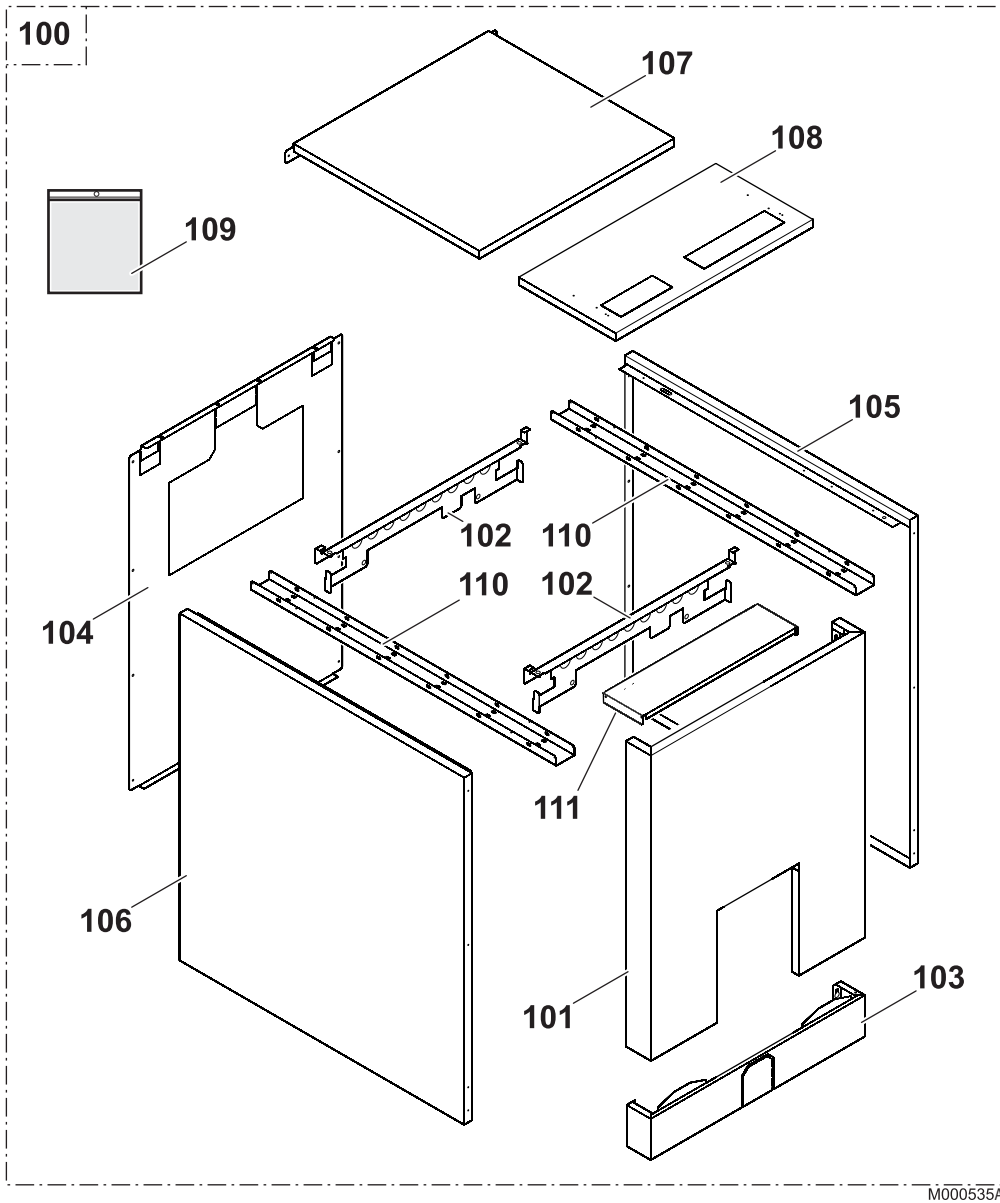

## Control panels

 Refer to the Spare Parts list in the panel instructions.

### S3 control panel - Package MD4

---

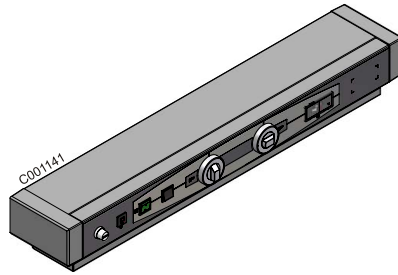

### K3 control panel

---

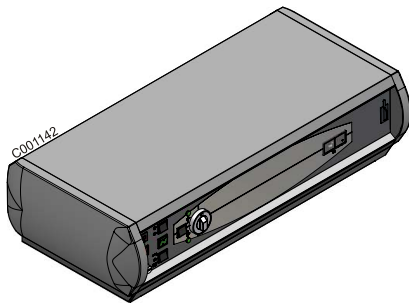

Separate panel - Package MD2

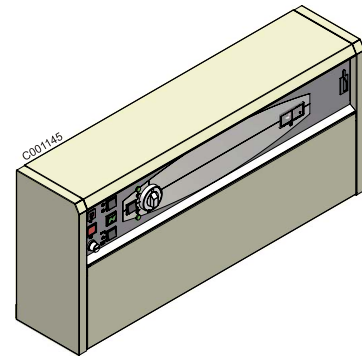

Side panel - Package MD139

### DIEMATIC-m3 control panel

---

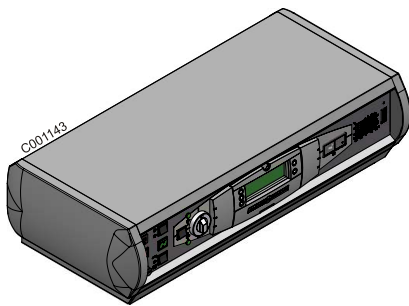

Separate panel - Package MD1

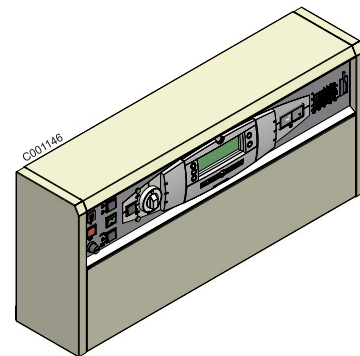

Side panel - Package MD138

### B3 control panel

---

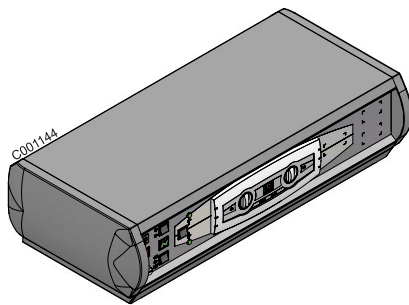

Separate panel - Package MD3

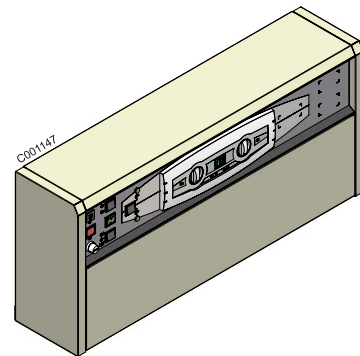

Side panel - Package MD140

Markers	Code no.	Description
		<b>Boiler body</b>
1	82198912	Complete rear section
2	8219-8966	Special intermediate section
3	8219-8976	Complete front section
4	8116-0571	Nipple
5	8219-8968	Complete assembly rod, 4 sections
5	8219-8969	Complete assembly rod, 5 sections
5	8219-8970	Complete assembly rod, 6 sections
5	8219-8971	Complete assembly rod, 7 sections
5	8219-8972	Complete assembly rod, 8 sections
5	8219-8973	Complete assembly rod, 9 sections
6.1	8202-0028	Plug 2 1/2" - 1/2"
6.2	8209-0049	Plug 2 1/2" - 1/2" - NL
6.3	94948080	Nipple N 241 - 1/2"x1/4"
7	9536-5611	Rp 1/2 sensor tube
8	8013-0028	Plug 2 1/2" - 1/2"
9	8553-5513	Flow flange, 4 to 9 sections
10.1	8553-5514	Return flange, 4 to 5 sections
10.2	8553-5515	Return flange + distribution pipe, 6 to 8 sections
10.3	8553-5516	Return flange + distribution pipe, 9 sections
10.4	9754-9178	Counter flange
11	9495-0249	Male plug 290 T9 - R 1 1/2
11.1	9501-4122	Flange gasket
12	8104-8984	Hinge
13	8219-8916	Sweeping door
14	9425-0306	Inner protection, sweeping door
15	9425-0305	Insulation, sweeping door
16	9508-6032	10 Ø thermocord gasket
17	9756-0203	Pin Ø 12x350
18	8219-8913	Ø 180 complete nozzle
18	8219-8914	Ø 200 complete nozzle
19	8219-0206	Right hand nozzle cover
20	8219-0207	Left hand nozzle cover
21	8219-8953	Complete combustion chamber door, ø 135
22	9425-0303	Internal protection, combustion chamber door
23	9425-0302	Furnace door guard
24	9425-0301	Furnace door insulation
25	8015-7700	Sight glass + gaskets
26	9757-0027	Inspection flange
27	9495-0050	Plug 1/4"
28	8219-0539	Guide rail for combustion chamber door
29	8219-0017	Upper baffle plate, 410

Markers	Code no.	Description
29	8219-0018	Upper baffle plate, 570
30	8219-0019	Lower baffle plate, 412
30	8219-0020	Lower baffle plate, 572
31	8219-7724	Body screws packet
32	8219-8957	Bag of screws for furnace door
33	9430-5027	0.3 kg can nipple lubricant
34	9428-5095	Mastic Novasil S 17
		<b>Miscellaneous</b>
50	9750-5025	Brush
51	9750-5076	1000 mm brush rod
51	9750-5060	1300 mm brush rod
		<b>Base frame</b>
70	8553-7060	Complete frame 4 sections Package FD 30
70	8553-7061	Complete frame 5 sections Package FD 31
70	8553-7062	Complete frame 6 sections Package FD 32
70	8553-7063	Complete frame 7 sections Package FD 33
70	8553-7064	Complete frame 8 sections Package FD 34
70	8553-7065	Complete frame 9 sections Package FD 35
		<b>Insulation</b>
90	8553-5507	Complete boiler body insulation, 4 sections
90	8553-5008	Complete boiler body insulation, 5 sections
90	8553-5509	Complete boiler body insulation, 6 sections
90	8553-5510	Complete boiler body insulation, 7 sections
90	8553-5511	Complete boiler body insulation, 8 sections
90	8953-5512	Complete boiler body insulation, 9 sections
		<b>Casing</b>
100	200005572	GT 334 casing - except : China
100	200005573	GT 335 casing - except : China
100	200005574	GT 336 casing - except : China
100	200005575	GT 337 casing - except : China
100	200005576	GT 338 casing - except : China
100	200005577	GT 339 casing - except : China

Markers	Code no.	Description
101	200005570	Front panel - except : China
101	200012251	Front panel - China
	200012791	H plate - GT334 (China)
	200012792	H plate - GT335 (China)
	200012793	H plate - GT336 (China)
	200012794	H plate - GT337 (China)
	200012795	H plate - GT338 (China)
	200012796	H plate - GT339 (China)
102	200004840	Upper crosspiece
103	200005571	Lower cap
104	200005032	Complete rear panel
105	200005033	Complete side panel right, 4 sections
105	200005034	Complete side panel right, 5 sections
105	200005035	Complete side panel right, 6 sections
105	200005036	Complete side panel right, 7 sections
105	200005037	Complete side panel right, 8 sections
105	200005038	Complete side panel right, 9 sections
106	200005039	Complete side panel left, 4 sections
106	200005040	Complete side panel left, 5 sections
106	200005041	Complete side panel left, 6 sections
106	200005042	Complete side panel left, 7 sections
106	200005043	Complete side panel left, 8 sections
106	200005044	Complete side panel left, 9 sections
107	200004830	Complete rear cover, 4 sections
107	200004831	Complete rear cover, 5 sections
107	200004832	Complete rear cover, 6 sections
107	200004833	Complete rear cover, 7 sections
107	200004834	Complete rear cover, 8 sections
107	200004835	Complete rear cover, 9 sections
108	200005045	Complete front cover
109	200005046	Screw bag
		<b>Cable channel</b>
110	200004849	4-section cable way
110	200004850	5-section cable way
110	200004851	6-section cable way
110	200004852	7-section cable way
110	200004853	8-section cable way
110	200004854	9-section cable way
111	200004841	Cable protection
		<b>Control panels</b>
		Refer to the connection instructions supplied with the control panel..

# Warranty

You have just purchased one of our appliances and we thank you for the trust you have placed in our products. Please note that your appliance will provide good service for a longer period of time if it is regularly checked and maintained. Your fitter and our customer support network are at your disposal at all times.

## ■ Warranty terms

Starting from the purchase date shown on the original fitter's invoice, your appliance has a contractual guarantee against any manufacturing defect.

The length of the guarantee is mentioned in the price catalogue.

The manufacturer is not liable for any improper use of the appliance or failure to maintain or install the unit correctly (the user shall take care to ensure that the system is installed by a qualified fitter). In particular, the manufacturer shall not be held responsible for any damage, loss or injury caused by installations which do not comply with the following:

- applicable local laws and regulations
- specific requirements relating to the installation, such as national and/or local regulations
- the manufacturer's instructions, in particular those relating to the regular maintenance of the unit
- the rules of the profession

The warranty is limited to the exchange or repair of such parts as have been recognised to be faulty by our technical department and does not cover labour, travel and carriage costs. The warranty shall not apply to the replacement or repair of parts damaged by normal wear and tear, negligence, repairs by unqualified parties, faulty or insufficient monitoring and maintenance, faulty power supply or the use of unsuitable fuel. Sub-assemblies such as motors, pumps, electric valves etc. are guaranteed only if they have never been dismantled.

## ■ France

The preceding dispositions are not exclusive of benefits for the purchaser of the legal guarantee as stated in Civil Code articles 1641 to 1648.

## ■ Poland

Warranty conditions are included in the warranty card.

## ■ Switzerland

The application of the warranty is subject to the terms and conditions of sale, delivery and warranty of the company marketing our products.

## ■ Belgium

The preceding dispositions about the contractual guarantee are not exclusive of profit if the need arises for the purchaser in Belgium of the applicable legal dispositions on hidden defects.

## ■ Italy

The duration of our warranty is shown on the certificate delivered with the appliance.

Our liability as manufacturer may not be invoked in respect of incorrect use of the appliance, incorrect or insufficient maintenance thereof, or incorrect installation of the appliance (you must therefore ensure that installation and maintenance operations are carried out respectively by a qualified professional and by an after sales service company).

The legislation laid down by European Directive 99/44/EEC, transposed by Legislative Decree No. 24 of 2 February 2002 published in O.J. No. 57 of 8 March 2002, continues to apply.

## ■ Russia

The foregoing provisions in no way affect the rights of the consumer, which are guaranteed by the legislation of the Russian Federation as regards hidden defects.

The terms and conditions of warranty and the terms and conditions of application of the warranty are indicated on the warranty form.

The warranty shall not apply as regards the replacement or repair of wearing parts under normal use. Such parts include thermocouples, injection nozzles, flame control and ignition systems, fuses and gaskets.

## ■ Turkey

Due to the laws and regulations the product life for this product is 10 years. During that time the producer and/or the distributor has to provide after sales services and spare parts.

## ■ Other countries

The above provisions do not restrict the benefit of the legal laws regarding hidden defects applicable in the buyer's country.





**DE DIETRICH THERMIQUE S.A.S**



[www.dedietrich-thermique.fr](http://www.dedietrich-thermique.fr)  
Direction des Ventes France  
57, rue de la Gare  
F- 67580 MERTZWILLER  
☎ +33 (0)3 88 80 27 00  
☎ +33 (0)3 88 80 27 99

**DE DIETRICH REMEHA GmbH**



[www.remeha.de](http://www.remeha.de)  
Rheiner Strasse 151  
D- 48282 EMSDETTEN  
☎ +49 (0)25 72 / 9161-0  
☎ +49 (0)25 72 / 9161-102  
info@remeha.de

**DE DIETRICH**



[www.dedietrich-otoplenie.ru](http://www.dedietrich-otoplenie.ru)  
129164, Россия, г. Москва  
Зубарев переулок, д. 15/1  
Бизнес-центр «Чайка Плаза»,  
офис 309  
☎ +7 (495) 221-31-51  
dedietrich@nnt.ru

**VAN MARCKE**



[www.vanmarcke.be](http://www.vanmarcke.be)  
Weggevoerdenlaan 5  
B- 8500 KORTRIJK  
☎ +32 (0)56/23 75 11

**NEUBERG S.A.**



[www.dedietrich-heating.com](http://www.dedietrich-heating.com)  
39 rue Jacques Stas  
L- 2010 LUXEMBOURG  
☎ +352 (0)2 401 401

**DE DIETRICH THERMIQUE Iberia S.L.U.**



[www.dedietrich-calefaccion.es](http://www.dedietrich-calefaccion.es)  
Av. Príncipe d'Astúries 43-45  
08012 BARCELONA  
☎ +34 932 920 520  
☎ +34 932 184 709

**DE DIETRICH SERVICE**



[www.dedietrich-heiztechnik.com](http://www.dedietrich-heiztechnik.com)  
☎ Freecall 0800 / 201608

**WALTER MEIER (Klima Schweiz) AG**



[www.waltermeier.com](http://www.waltermeier.com)  
Bahnstrasse 24  
CH-8603 SCHWERZENBACH  
+41 (0) 44 806 44 24  
Serviceline +41 (0)8 00 846 846  
☎ +41 (0) 44 806 44 25  
ch.klima@waltermeier.com

**WALTER MEIER (Climat Suisse) SA**

[www.waltermeier.com](http://www.waltermeier.com)  
Z.I. de la Veyre B, St-Légier  
CH-1800 VEVEY 1  
☎ +41 (0) 21 943 02 22  
Serviceline +41 (0)8 00 846 846  
☎ +41 (0) 21 943 02 33  
ch.climat@waltermeier.com

**DUEDI S.r.l.**



[www.duediclima.it](http://www.duediclima.it)  
Distributore Ufficiale Esclusivo  
De Dietrich-Thermique Italia  
Via Passatore, 12 - 12010  
San Defendente di Cervasca  
CUNEO  
☎ +39 0171 857170  
☎ +39 0171 687875  
info@duediclima.it

**DE DIETRICH**



[www.dedietrich-heating.com](http://www.dedietrich-heating.com)  
Room 512, Tower A, Kelun Building  
12A Guanghua Rd, Chaoyang District  
C-100020 BEIJING  
☎ +86 (0)106.581.4017  
+86 (0)106.581.4018  
+86 (0)106.581.7056  
☎ +86 (0)106.581.4019  
contactBJ@dedietrich.com.cn

**BDR Thermea (Czech republic) s.r.o**



[www.dedietrich.cz](http://www.dedietrich.cz)  
Jeseniova 2770/56  
130 00 Praha 3  
☎ +420 271 001 627  
☎ +420 271 771 468  
info@dedietrich.cz

AD001-AH

© Copyright

All technical and technological information contained in these technical instructions, as well as any drawings and technical descriptions supplied, remain our property and shall not be multiplied without our prior consent in writing.

Subject to alterations.

05/03/2013



300007650-001-02

**De Dietrich**



DE DIETRICH THERMIQUE  
57, rue de la Gare F- 67580 MERTZWILLER - BP 30