

# ELIDENS C140

FLOOR-STANDING GAS CONDENSING BOILER  
FOR HEATING ONLY

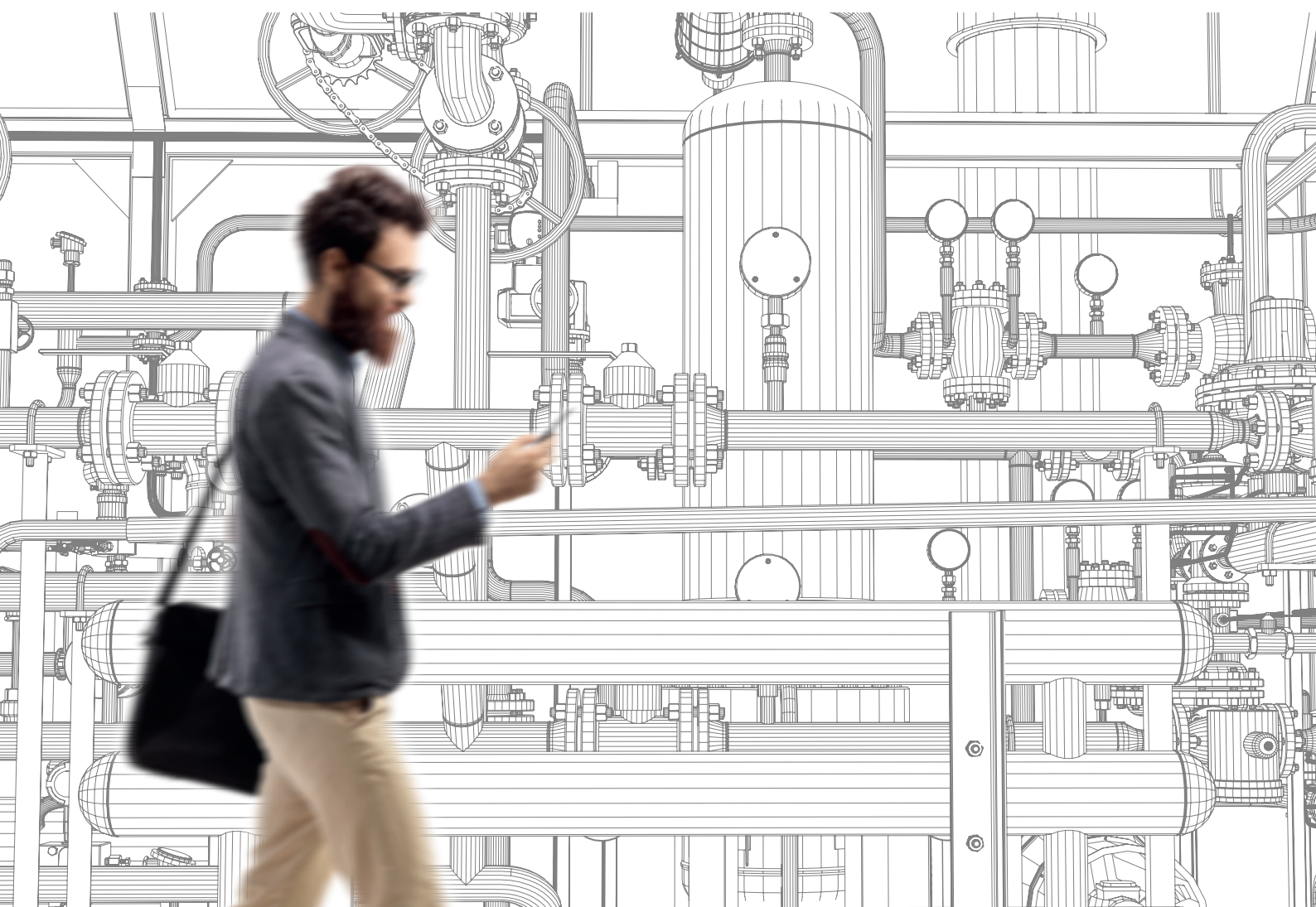

# SPECIFICATIONS

## ADVANTAGES OF THE ELIDENS C140 RANGE



### EASY MAINTENANCE

- Full access to the boiler from the front
- Reinforced protection through hydraulic kit

### CASCADE (2 TO 8 BOILERS)

- Connection kit identical to the former Elidens DTG 130 range

### FLUE GAS SYSTEM

- B23P, C13, C33
- Integrated cascade flue gas valve

### PERFORMANCE

- 45 to 115 kW output
- Condensing
- 108 to 110% efficiency
- NOx class 6
- Flow rate proportional to output
- $\Delta T$  40 °C (DHW production)
- C140-115  $\Delta T$  35 °C

### BURNER MODULATION

- Range 18/100%

### SOUND POWER

- Less than 61 dB(A)

### AVAILABLE IN 3 VERSIONS

- Boiler only
- Boiler with low-loss header (... SH)
- Boiler with plate heat exchanger (... EPI)



### NEW: EASY INSTALLATION

- Low-loss header hydraulic kit (SH)
- Plate heat exchanger hydraulic kit (EPI)
- Modulating pump
- Transport wheels

### MODBUS COMMUNICATION

### NEW REGULATOR

- Intuitive, simple and functional
- Heating until 3 circuits direct or mixing valve circuits
- Domestic hot water
- Optional 3rd valve

### HYDRAULIC CONNECTION

- Identical to Elidens DTG130
- Can be replaced without the need to modify the pipework and flue

### COMPACT

- 600 mm wide, 715 mm deep
- Weight of 1 kg per 1 kW



## EASY INSTALLATION COMPACT DIMENSIONS



width  
600 mm  
depth  
715 mm

Weight 1 kg  
for 1 kW

Cascade  
configuration

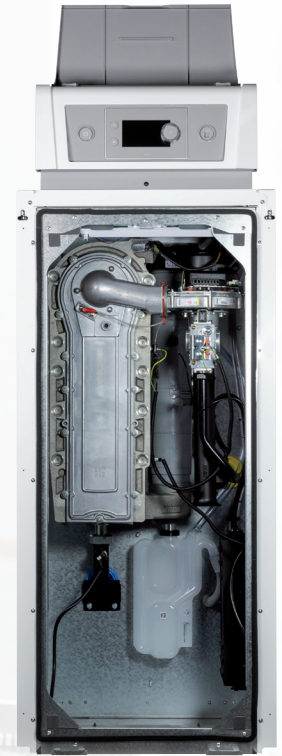

## BESPOKE CONTROL SYSTEM

### DIEMATIC EVOLUTION

This is a highly advanced panel with new ergonomic controls, with a built-in programmable electronic control system.

The Diematic Evolution control panel offers innovative features:



**MASTER BOILER**  
Depending on the outdoor temperature by activating the modulating burner.

Control:

- 1 DHW circuit
- 2 direct zones
- 3 mixed circuits
- cascades of 2 to 8 boilers

### INICONTROL 2

This is mainly used in installations (cascade or use only) with an external control cabinet to control all of the secondary circuits via a 0-10V input, which this panel is fitted with as part of its original equipment.

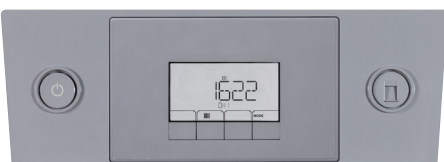

**SLAVE BOILERS  
(BUS CONNECTION).**

Control:

of the boiler only  
with a 0-10 V signal

# SET-UP

## BOILER ROOM OPTIMISATION

This design gives a range of boilers which are very compact and lightweight with a minimal footprint and a maximum weight of 110kg for 110kW. Hard-to-access boiler rooms are no longer a problem!

The Elidens C140 range offers many advantages for a boiler room:

- Fully-equipped compact versions (SH).
- Easy connection.
- Good accessibility around the boiler.
- The variable flow pump adjusts the Q1 flow rate to obtain the highest  $\Delta T$  possible.
- The entire system (Boiler + KIT) enables zero-flow operation.

### • BOILER ONLY

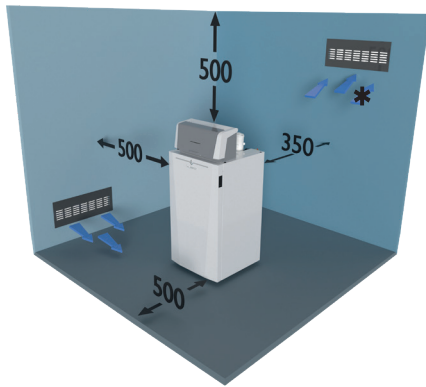

### • SH AND EP BOILER VERSIONS (with rear-mounted low-loss header kit)

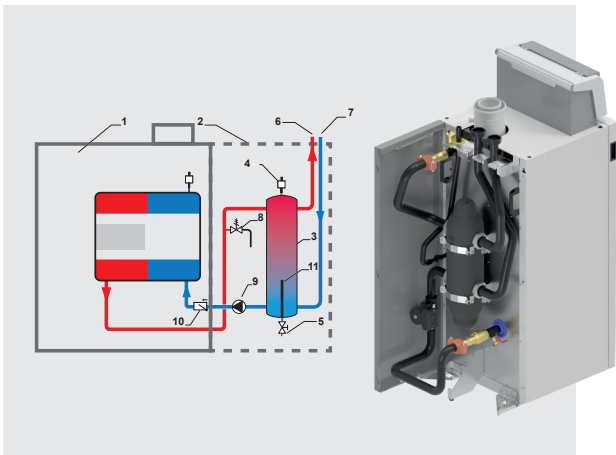
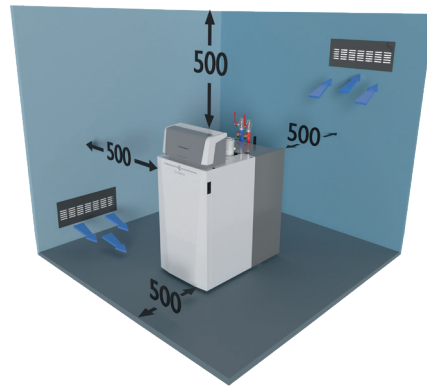

### SEPARATION KIT

WITH LOW-LOSS HEADER C140 - ...SH

The C140 SH and EP versions are equipped with installation kits on the rear of the boilers, allowing the hydraulic separation of the primary circuit from the secondary circuit.

It therefore protects the boiler unit against impurities in the water in the secondary heating circuit.

### INSTALLATION SCENARIO

- The 2 versions (SH and EP) allow for operation at zero flow
- A neutral point may be set hydraulically,
- Sediment may be filtered and removed thanks to the filtering function (only for the version with SH kit).

### SEPARATION KIT

WITH PLATE HEAT EXCHANGER C140-...EP

In the case of an installation where the water quality is not managed (frequent back-ups or build-up of sediment), we offer a plate heat exchanger + modulating pump assembly to separate the primary circuit and the old, heavily oxidised secondary circuits to protect the boiler.

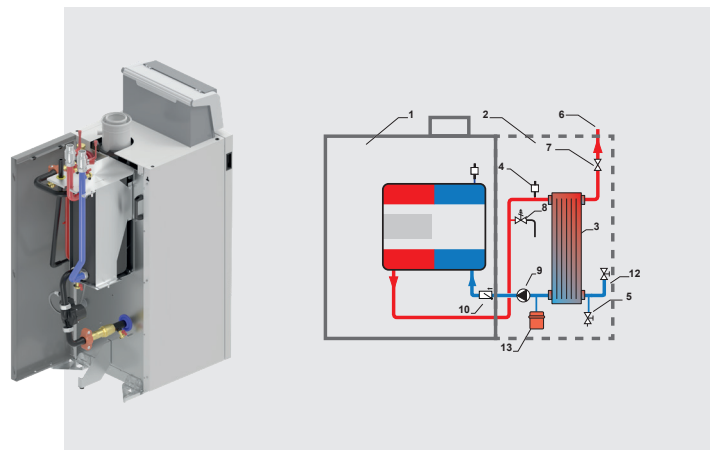

# TO TAKE IT FURTHER

## INSTALLATION EXAMPLES

### C140-...

Installation of a C140-... with 2 circuits including 1 with a mixing valve and DHW production with a DHW tank (tank equipped with 2 DHW sensors).

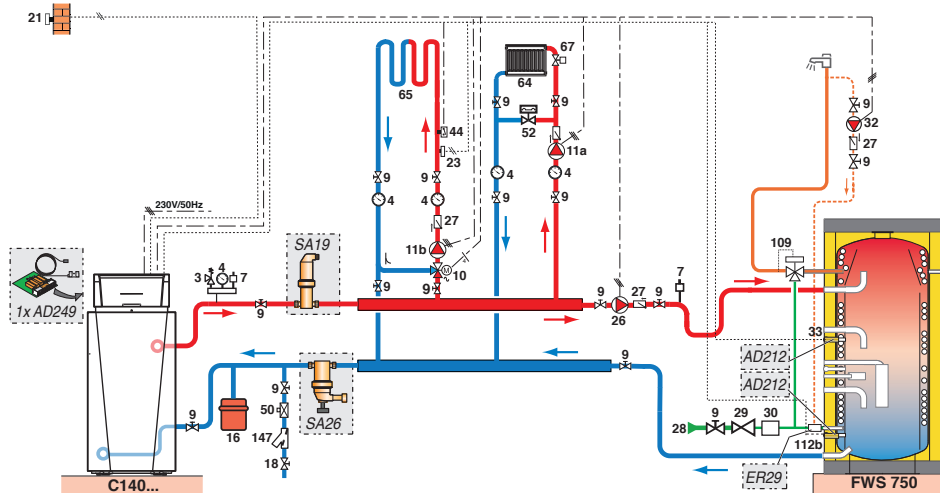

### CASCADE OF 2 C140-... DIEMATIC EVOLUTION BOILERS, EP VERSION

Cascade installation of 2 C140-...DIEMATIC EVOLUTION. 3 mixing zones, a clarifier set shunted to the heating return to remove residue in the installation. DHW is made by an FWPC semi-instantaneous DOMESTIC HOT WATER tank linked to a PSB buffer.

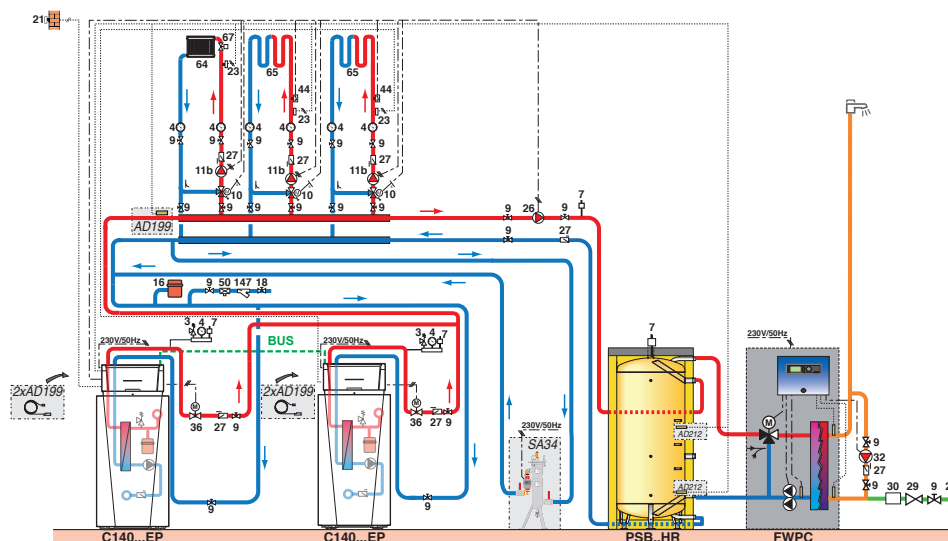

# SPECIFICATIONS

		MODELS	C140...	45	65	90	115
Useful output	• nominal determined at Qnom (1) (Pn_gen)		kW	40.8	61.5	84.2	103.9
	• intermediate at 30% Qnom (1) (Pint)		kW	13.7	20.5	27.9	34.8
Nominal output Pn at 50/30°C			kW	42.4	65.0	89.5	109.7
Efficiency in % LCV, load... % and water temp....°C	• 100% Pn, at ave. temp. 70 °C (RPn)*		%	99.1	99.2	97.9	97.1
	• 30% Pn, at ret. temp. 30 °C (Rpint)*		%	110.6	110.4	108.1	108.0
Seasonal energy efficiency: Product Etas (without control system)			%	95	94	—	—
Seasonal energy efficiency: Etas (with temperature sensor as standard)			%	97	96	—	—
Useful efficiency at ...% of the nominal heat output	• at 100% Eta 4		%	—	—	88.2	87.5
	• at 30 % Eta 1		%	—	—	97.4	97.3
Modulation rate			%	20 to 100	19 to 100	17 to 100	18 to 100
Nominal water flow rate at Pn and ΔT = 20 K			m <sup>3</sup> /h	1.75	2.65	3.62	4.47
Stand-by losses at ΔT = 30 K (QPO30)*			W	105	114	119	119
Electrical output of auxiliaries at (Qaux nom)*			W	68	92	124	180
Electrical output of auxiliaries in standby (Qveille)			W	4	6	5	9
Useful output at 50/30°C min./max.			kW	9.1/42.4	13.5/65.0	15.8/89.5	21.2/109.7
Useful output at 80/60°C min./max.			kW	8/40.8	12/61.5	14.1/84.2	18.9/103.9
Flue gas mass flow rate min./max.			g/s	3.9/19.2	5.8/28.9	7.8/38.3	10.0/49.4
Pressure available at boiler outlet			Pa	150	100	160	220
Water content			l	5.2	7.1	10.1	10.1
Minimum water flow rate required if flow T° >75 °C			l/h	195	290	340	455
Max. ΔT°			°C	40	40	40	35
Maximum operating temperature			°C	90	90	90	90
Maximum operating pressure (MOP)			bar	4	4	4	4
Water side pressure drop at ΔT = 20 K			mbar	110	170	160	260
Sound power			dB(A)	55	55	61	60
Max. gas flow rate (15 °C-1013 mbar)	• natural gas H		m <sup>3</sup> /h	4.4	6.6	9.1	11.7
	• natural gas L		m <sup>3</sup> /h	5.1	7.6	10.6	13.6
	• propane		m <sup>3</sup> /h	1.7	2.5	3.5	4.5
Weight (empty)			kg	87	98	109	109

(1) Qnom = nominal heat output

\* Certified value

## A SYMBOL OF FRENCH QUALITY

For three hundred years, De Dietrich's success has been a expectation based on true values: quality, reliability, durability.

In the interest of the environment and your comfort, De Dietrich perfectly manages various renewable energies using multi-energy systems to protect the planet. Thanks to the collaboration of our entire team, De Dietrich heating systems lead the way in innovation and offer optimal quality and rare longevity.

Your installer

# De Dietrich

BDR THERMEA France  
S.A.S. with corporate capital of €229 288 696  
57, rue de la Gare - 67580 Mertzwiller  
Tel.: +33 3 88 80 27 00 - Fax +33 3 88 80 27 99  
www.dedietrich-heating.com

BDR THERMEA GROUP