



DAVE

EXTRACT & SUPPLY
SOLUTIONS



FOR THE COMPLETE VENTILATION SOLUTION



extract and supply...

pedigree

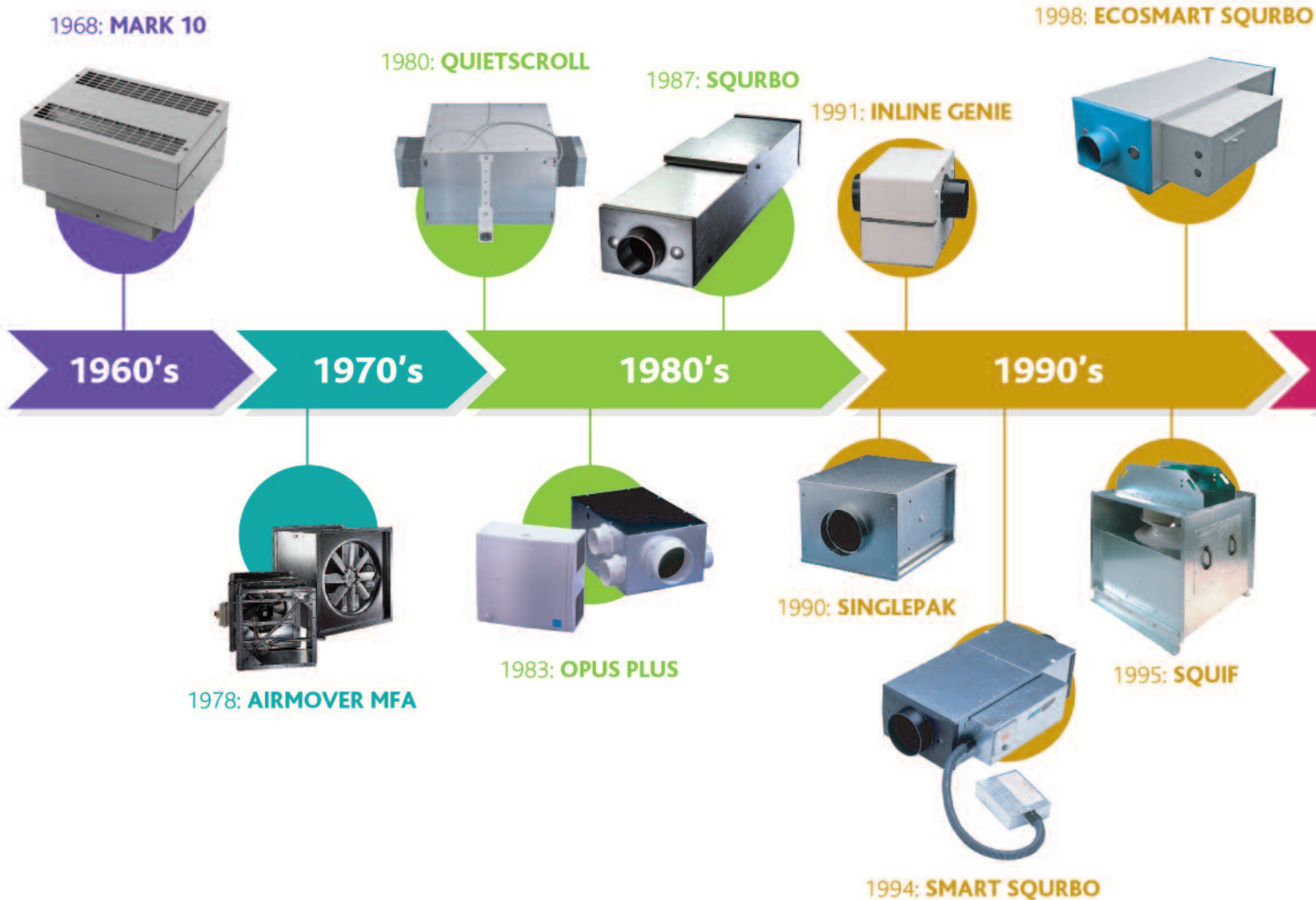

Since its inception in the early 1960's Nuaire has been at the forefront of the ventilation industry and is acknowledged for its expertise, commitment to innovation and the outstanding quality of its ventilation products and customer service.

Nuaire encompasses technologies at all levels to be able to offer the complete ventilation solution for the built environment. Nuaire has leading experts who are constantly setting new standards for the industry by developing new, innovative products in the company's research and development department – the largest and most advanced in the UK.

Over the last 50 years Nuaire has been particularly renowned for its supply and extract fans and have progressed and expanded its ranges which include iconic brands such as Opus, Genie, Airmover and Ecosmart Sqrbo.

The Ecosmart Sqrbo started life as the Smart Sqrbo which was revolutionary in its day as it was the only packaged supply fan, filter, heater and control packaged into a single compact unit. The fan fast became the UK's top selling supply & extract system outselling the long winded, costly conventional supply and extract systems available.

Nuaire has always tried to inject some humour into a somewhat dower industry by branding their ranges with very memorable names, for instance there is the Sqrbo, the Squif and the Xtractor through to the recently launched DAVE.

DAVE is dynamic, attenuated ventilation equipment.

DAVE extract and supply fans represent Nuair's latest innovation...

- Dynamic & compact solution by duty size
- Attenuated* to ensure lowest case breakout
- Ventilation with Patented 'floating fan' design
- EC technology designed to meet latest legislation & building regulations

*Attenuation pods are standard on 'PLUS' units.

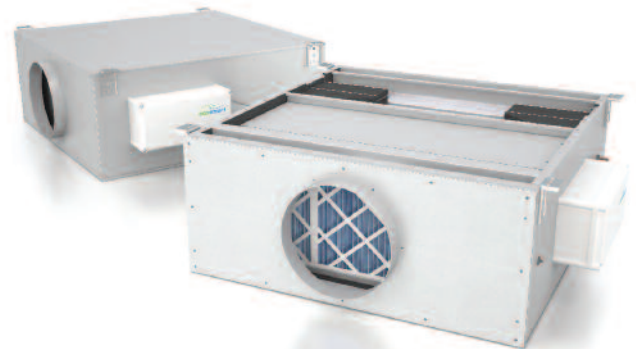

2001: EXTRACTOR

2012: AIRVOLVE

2000's

2010's

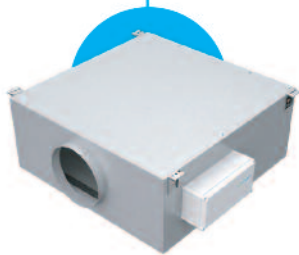
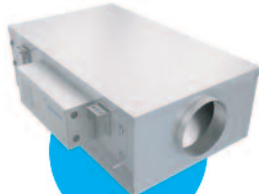

2008: ES-OPUS DC

2015: DAVE

CONTENTS

2 - 3	EXTRACT & SUPPLY PEDIGREE
4 - 5	A COMPLETE VENTILATION SERVICE
6 - 7	OPTIMISING VENTILATION SOLUTIONS
8 - 11	DAVE ECOSMART ENERGY EFFICIENT SOLUTION
12	DAVE EXTRACT FANS, FEATURES & BENEFITS
13 - 14	DAVE EXTRACT FANS, SPECIFICATIONS
15	DAVE EXTRACT FANS, WIRING
16	COMPLYING WITH BUILDING REGULATIONS
17 - 25	DAVE EXTRACT FANS, SIZES 1-7
26	DAVE SUPPLY FANS, FEATURES & BENEFITS
27 - 29	DAVE SUPPLY FANS, SPECIFICATIONS
30 - 31	DAVE SUPPLY FANS, WIRING
32 - 40	DAVE SUPPLY FANS, SIZES 1-7
41 - 44	DAVE ANCILLARIES
45	ACOUSTIC GUIDELINES
46 - 47	AIREVOLVE SINGLE & TWINFANS

DAVE EXTRACT - UNIT PERFORMANCE

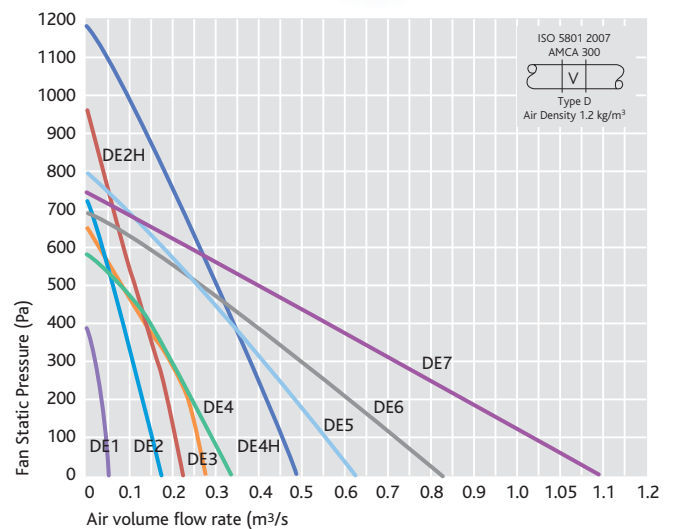

For accurate figures, please refer to pages 17 to 25.

DAVE SUPPLY - UNIT PERFORMANCE

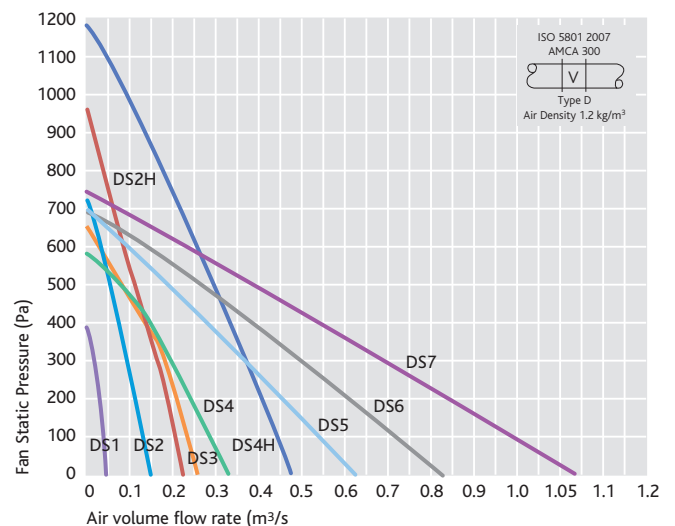

For accurate figures, please refer to pages 32 to 40.

A COMPLETE VENTILATION SERVICE FROM DESIGN TO CUSTOMER SERVICE

Our professional approach to business has led us to be members of, and participate in:



Registered No. EMS517710



Registered No. FM00149



Registered No. OHS553456



Registered No. IMR609253



At Nuaire we offer more than just the leading fans on the market. We offer a complete ventilation service that starts with your concept and includes support, installation advice, excellent after-sales support and even product installation training to ensure you get it right first time.

We understand the many challenges a modern building designer faces, and the regulations that building ventilation must meet, and our full service is designed to make our customers' lives easier from start to finish.

We implement all the relevant industry standards to ensure that all our processes and components are certified. We were the first fan manufacturer in the world to achieve the quality standard ISO 9001, and its commitment to quality remains embedded in all aspects of its operations.

- 1st ventilation manufacturer to achieve ISO9001
- 1st ventilation manufacturer to achieve the Carbon Trust Standard 2009
- 1st ventilation manufacturer to achieve the Queen's Award for Innovation in 2004
- 1st ventilation manufacturer to have AMCA & BSI independently certified test laboratory

DESIGN

With over 20 years of experience Nuaire is able to offer full technical support through bespoke drawings and using the latest technology including REVIT and BIM, helping you find the best solution for your project.

ADVICE

We use the latest technology to ensure our ventilation products meet and often exceed all current legislation and codes of practice. And we don't stop there. Our unique fan selection software helps you choose the right products to meet your specification; while our staff provide expert advice for all aspects of our products and services.

CPD SEMINARS & TRAINING

Nuaire offers CPD seminars on a range of topics from new building regulations to specific ventilation and noise requirements for particular applications. And as part of our commitment to our customers, Nuaire now offers BPEC domestic ventilation installer training, free of charge from our headquarters in South Wales.



TECHNICAL DRAWINGS

Unlike many of our competitors, Nuaire sell direct to the end customer through our team of 65 technical sales engineers based throughout the UK and Ireland. This expert team arrange face-to-face meetings with customers and can give personalised advice on the spot.

CUSTOMER CARE

Our market position is not just defined by the innovative nature of our products but also our approach to business - we are proud to offer our customers an unbeatable customer service experience and regularly survey our customer to make sure we continuously improve. Find out more about our commitment to customer service and how it can benefit you.

“ We continually monitor our customer service offering. We ensure that it’s the best in the industry and exceeds our customer expectations ”

Wayne Glover, Sales Director



98.6%
OF OUR PRODUCTS
DELIVERED
ON TIME

EXTRACT AND SUPPLY SOLUTIONS

OPTIMISING VENTILATION SOLUTIONS FOR OFFICE ENVIRONMENTS TO CREATE A PLEASANT INDOOR AIR QUALITY IN THE MOST EFFICIENT WAY.

A good indoor climate creates a good environment for your workforce. A good working environment can make a big difference for the individual. Studies have shown that a poor indoor climate can affect productivity by as much as 13-15%. The number of errors made goes up two fold as temperatures rise above the 20°C.

In an open-plan office with large numbers of workers, heat emissions will be high, not to mention the heat given off by computers, etc. There also may be large sunlit glazed areas which also help to make the air hot and heavy.

Ventilation removes the air pollution caused by people and machines and replaces it with new, fresh air. This gives a greater feeling of well-being, and, all things being equal, makes employees more productive.

Nuair have a wide portfolio of ventilation solutions for non-residential buildings such as offices, schools, pubs or restaurants, delivering durability and reliability. The ranges covered on these two pages show a snap shot of Nuair's supply & extract ranges all of which are suitable for new build and refurbishment projects and are available in a variety of sizes and suitable for interior and exterior applications.

For further details please visit www.nuair.co.uk/commercial.

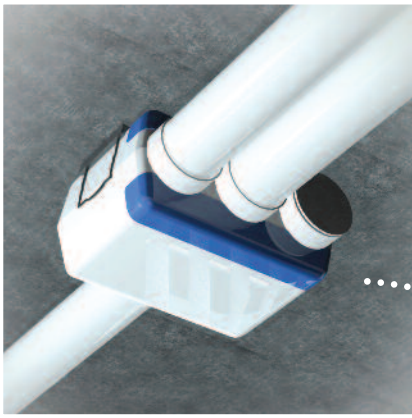

◀ (Model: ES-OPUS DC).
Low depth (184mm) extract unit.

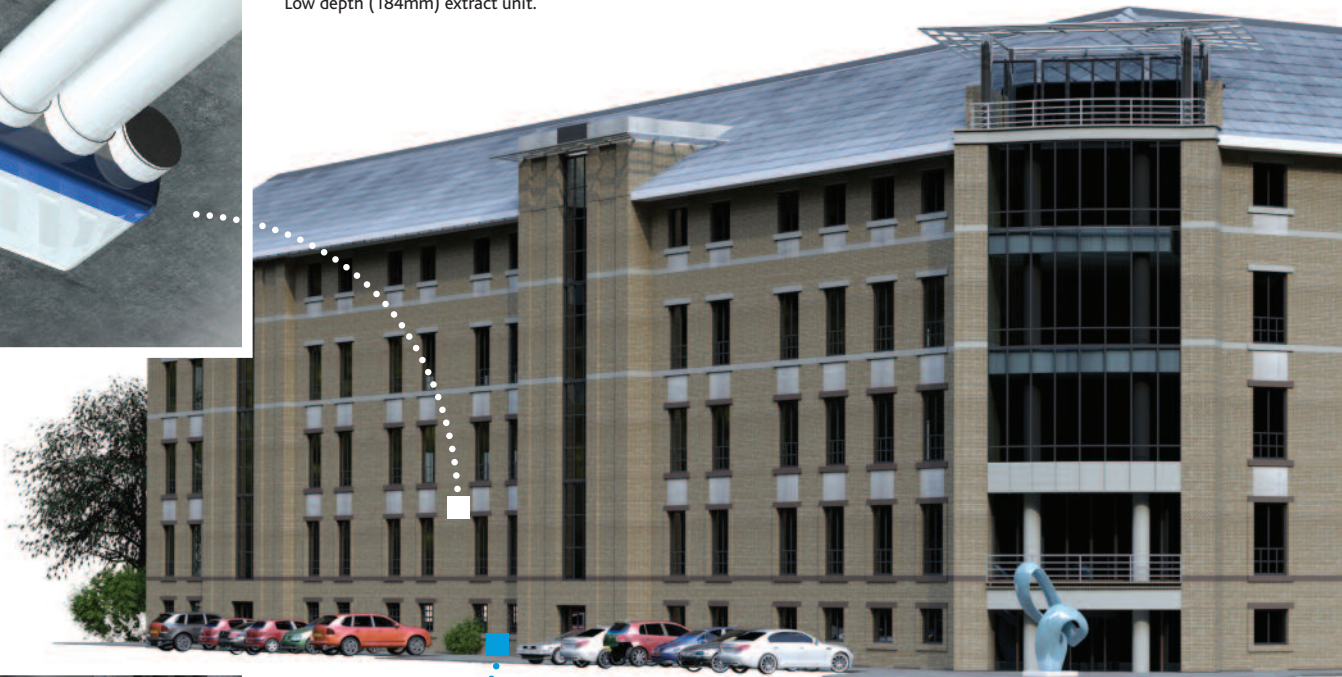

▲ (Model: DAVE DE3-ES)
Wall mounted DAVE extract unit.

ZONAL & CENTRALISED UNITS



AIRE-VOLVE AVS & AVT
(up to 1.8m³/s)
Market leading low profile single & twin fans. Very low energy consumption and SFP's.

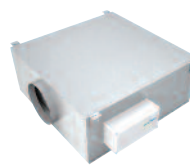

DAVE SUPPLY & EXTRACT
(up to 1.1m³/s)
Supply and extract range of single fans.



BOXER BESPOKE
(up to 20m³/s)
Designed to meet project specific applications. Includes rotary wheels, plate heat exchangers & run around coils.

(Model: XBC85-V-LESWP) ▶
Plant room or externally mounted
(with weather roof).

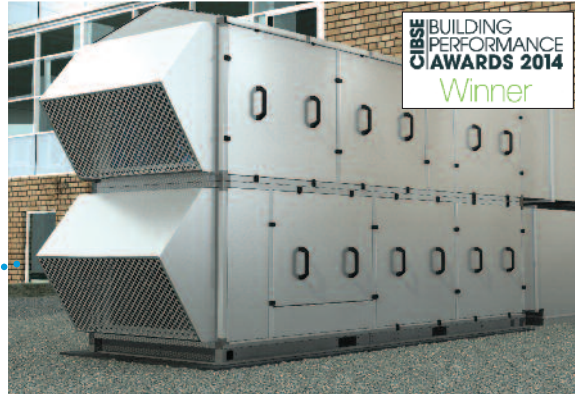

LOCAL UNITS

XS 6/9/12 (up to 530l/s)
High performance multi-purpose wall, ceiling, panel and roof extract fans.



ECOSMART SQUIF (up to 6.5m³/s)
Inline unit with motor out of air stream. Cost effective low maintenance. Easy to install and suitable for external mounting. Ambient and High temperature ranges.



OPUS 40/60/95 (up to 95l/s)
High performance wall and ceiling extract range complete with Ecosmart control.



ES OPUS DC (up to 110l/s)
High performance, low noise ceiling void extract range with very low profile complete with Ecosmart control.

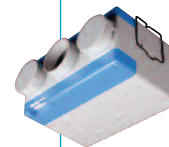

ECOSMART AIRMOVER (up to 10.6m³/s)
High performance backward curved Centrif, exceptionally quiet, low maintenance, easy to install and suitable for external mounting.

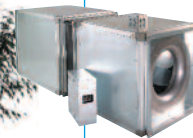

GENIE DC (up to 31l/s)
A market leading 100mm bathroom and kitchen extract range for wall and ceiling applications.



MEV FAMILY (up to 98l/s)
A range of multi-point energy efficient, low depth central extract fans. Unique locating bracket can be fixed in any plane – ideal for 1st or 2nd fix.

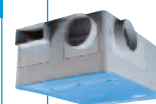

MRXBOX95 SERIES (up to 180l/s)
Compact heat recovery range for wall and cupboard applications.



XBOXER XBC (up to 1.5m³/s)

Market leading heat recovery units, up to 96% efficient.



AXT STAIRWELL PRESSURISATION SYSTEM (up to 73m³/s)

High temperature 'run & standby' axial fan
Ideal system for stairwell pressurisation.
Optional access doors make observation, & maintenance very quick & easy to install.

DAVE - ECOSMART ENERGY EFFICIENT SOLUTION

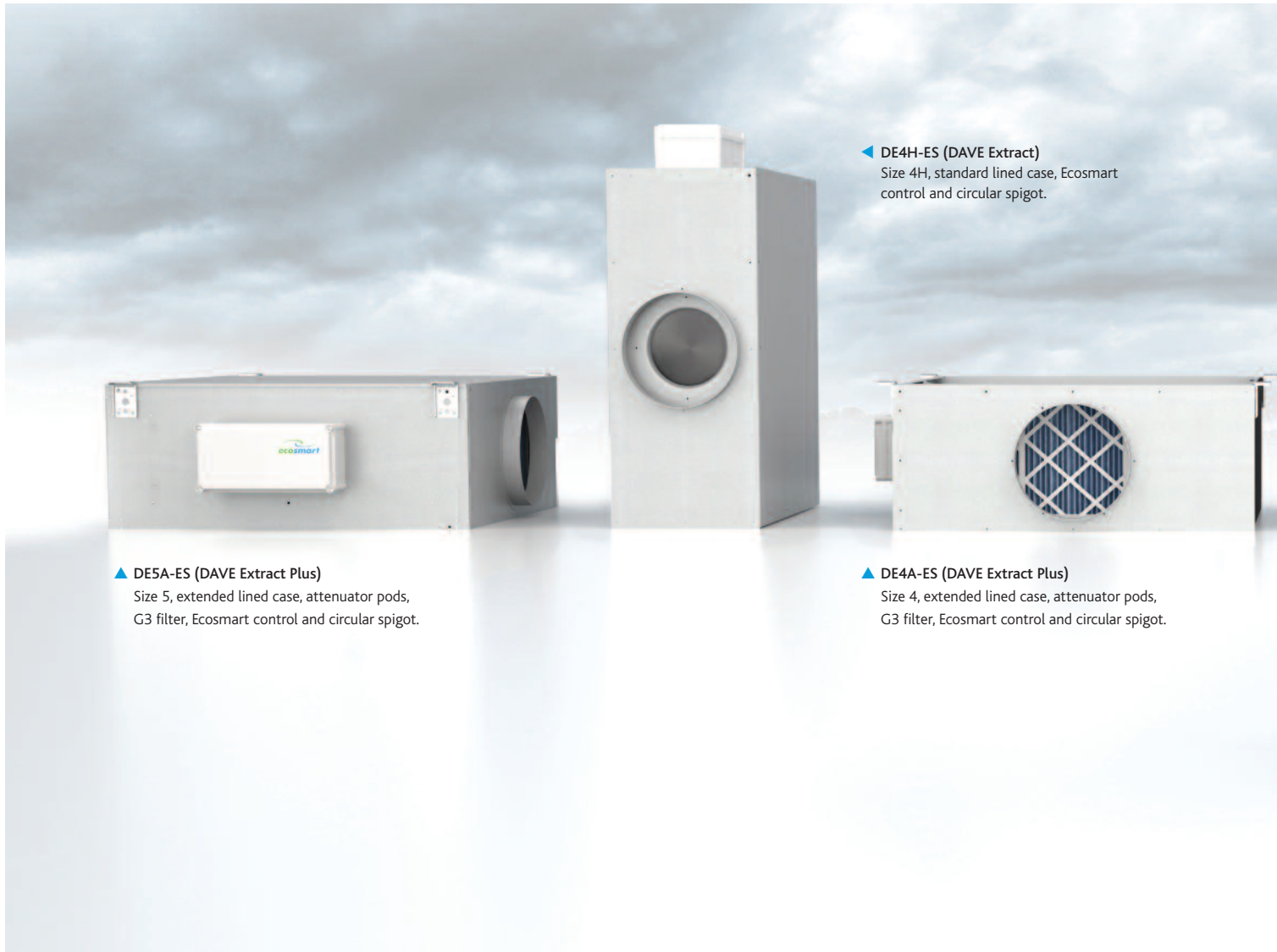

▲ **DE5A-ES (DAVE Extract Plus)**
Size 5, extended lined case, attenuator pods, G3 filter, Ecosmart control and circular spigot.

◀ **DE4H-ES (DAVE Extract)**
Size 4H, standard lined case, Ecosmart control and circular spigot.

▲ **DE4A-ES (DAVE Extract Plus)**
Size 4, extended lined case, attenuator pods, G3 filter, Ecosmart control and circular spigot.

FAN UNIT CODING DESCRIPTIONS

DE1-ES

|||
1 2 3 4

1. DAVE Range
2. Extract fan
3. Case size standard size (1-7)
4. ES = Ecosmart control

DE4HA-ES

|||||
1 2 3 4 5 6

1. DAVE Range
2. Extract fan
3. Case size (1-7)
4. H = High pressure fan (Size 2 & 4 only)
5. Case type: A = Extended
6. ES = Ecosmart control

DS7A-LES

|||||
1 2 3 4 5 6

1. DAVE Range
2. Supply fan
3. Case size (1-7)
4. Case type: A = Extended
5. L = LPHW Coil/valve
E = Electric heater,
N = No heater
6. ES = Ecosmart control

Note: High Pressure versions are available for fan sizes 2 & 4 only.

GENERAL NOTE:

All units are suitable for internal or external applications.

WHAT CONTROL OPTIONS ARE AVAILABLE?



THE MOST SUCCESSFUL ENERGY CONTROL EVER - DEMAND VENTILATION AT YOUR FINGER TIPS

Varying the ventilation rate in a building to suit changing occupant levels used to be an expensive option – Ecosmart brings this within everyone's pocket.

Minimising energy losses through re-heating (or cooling) the air replaced through ventilation is at the top of the agenda; building regulations make this a necessity. Ecosmart not only saves energy and carbon emissions it prolongs the life of the unit.

Choosing Ecosmart is your reliable option, used by design engineers for many years and is now an integral feature of most Nuair fans.

SAVES TIME ON SITE

Ecosmart controls are all pre-assembled, configured and installed directly to the units, which helps significantly reduce the time spent on site.

SIMPLER SYSTEM

No need for VCD (directly on the fan), no wasted energy or noise generation because air volume can be precisely set via integrated speed control.

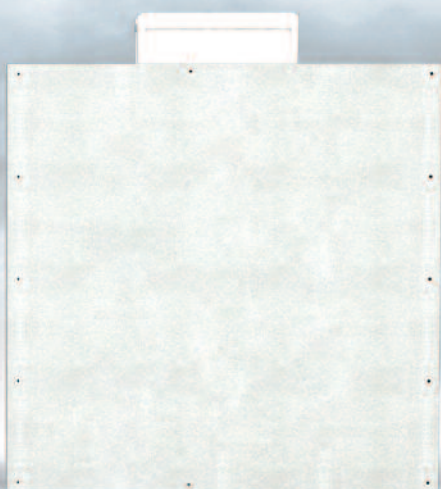

◀ **DE3-ES (DAVE Extract)**
Size 3, standard lined case, Ecosmart control and circular spigot.



▼ **DS6A-ES (DAVE Supply Plus)**
Size 6, extended lined case, attenuator pods, G3 filter, Ecosmart control and circular spigot.



▼ **DS4H-ES (DAVE Extract)**
Size 4H, standard lined case, Ecosmart control and circular spigot.



▲ **DS5A-LES (DAVE Supply Plus)**
Size 5, extended lined case, LPHW coil/2 port Pressure Independent valve, attenuator pods, G4 filter, Ecosmart control and circular spigot.

▼ **DS6A-EES (DAVE Supply Plus)**
Size 6, extended lined case, Electric heater & thyristor control, attenuator pods, G4 filter, Ecosmart control and circular spigot.

CONTROL CHECKLIST - WHAT'S INCLUDED

SIMPLE & PRECISE COMMISSIONING

As recommended in Part L, Ecosmart enables the system to be accurately commissioned via integrated speed control. If the unit is controlled by 0-10V BMS the system's response to a 0-10V dc BMS signal is given below.

	Ventilation mode	Heating mode*
Local control	0.00	-
OFF / trickle	0.25	-
Speed 1	0.50	1.00
Speed 2	1.50	2.00
Speed 3	2.50	3.00
Speed 4	3.50	4.00
Speed 5	4.50	5.00
Speed 6	5.50	6.00
Speed 7	6.50	7.00
Speed 8	7.50	8.00
Speed 9	8.50	9.00
Speed 10	9.50	10.00

* Only available on relevant unit.

QUIETER SYSTEMS

With Ecosmart your system is only at maximum design duty when necessary. **Ecosmart has a 5 year warranty.**

The controls indicated in the checklist below are incorporated in the units as standard, enabling you to co-ordinate your controls to avoid duplication and reduce costs. Please refer to this when checking the controls specification.

www.nuairegroup.com/specifications

DAVE Extract	DAVE Supply	
●	●	BMS compatible
●	●	Commissioning control
●	●	Run/Fail signal (volt free)
●	●	Speed control (single phase)
	●	Pre-piped coil (c/w DRV)
	●	Motorised control valve (c/w actuator)
	●	Air off Temp stat
	●	Frost protection
	●	Heat dissipation run on
●	●	Plug-in sensors (see overleaf)
●	●	Trickle and Boost switch

DAVE EXTRACT AND SUPPLY CONTROL COMPARISON

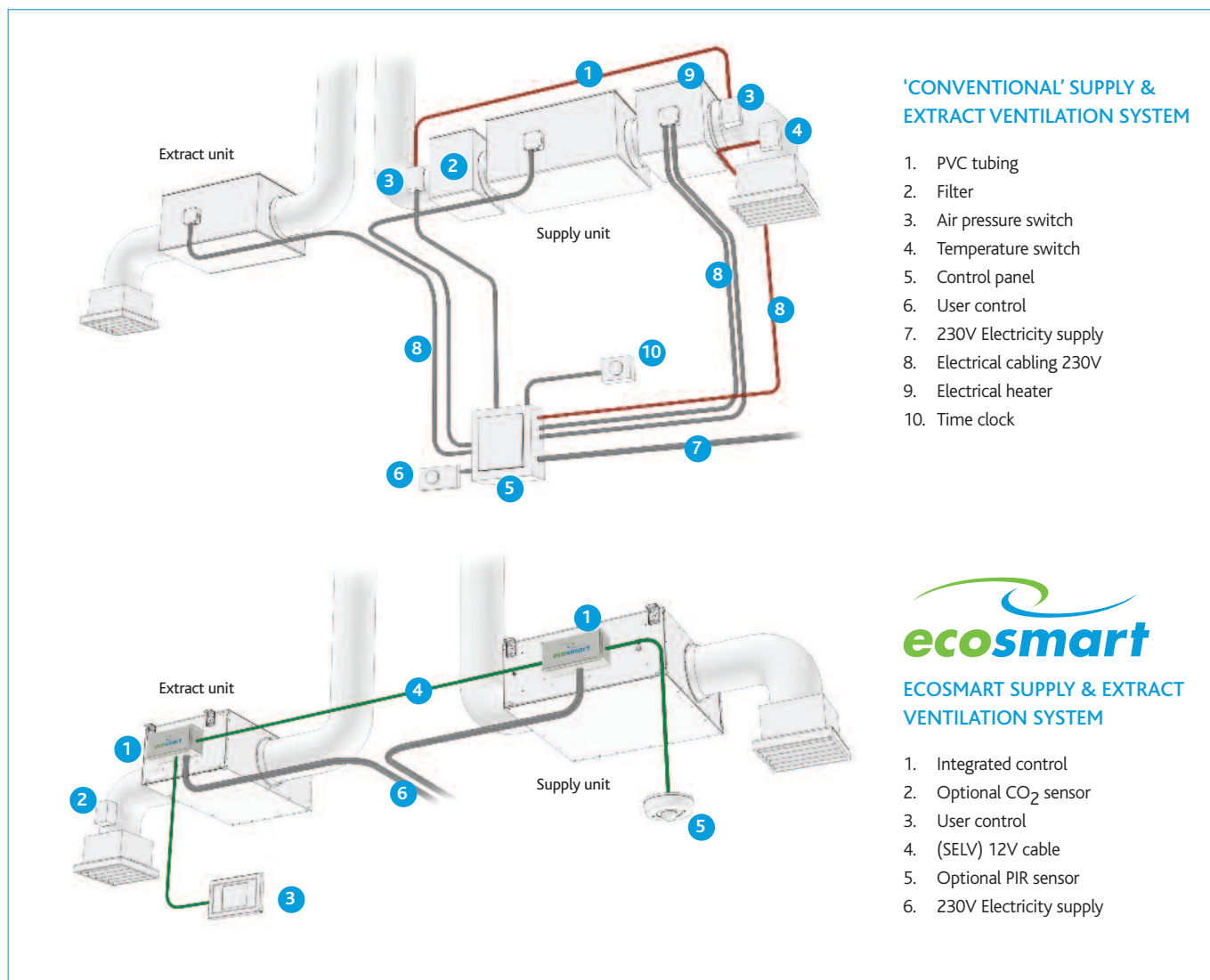

SIMPLE TO INSTALL

All controls are pre-assembled, configured and installed directly into the fan. Site time kept to a minimum, quality and efficiency maintained.

SIMPLER SYSTEMS

No need for main VCD, no wasted energy or noise generation because the air volume can be precisely set via the integrated speed control, minimum and maximum speeds easily adjusted via Ecosmart commissioning panel.

SIMPLE, PRECISE COMMISSIONING

As recommended in Part L, Ecosmart enables the system to be accurately commissioned via an integrated speed control, minimum and maximum speeds easily adjusted via commissioning panel integral to the control.

QUIETER SYSTEMS

With Ecosmart your system is only at maximum design duty when absolutely necessary. The noise levels within your systems are lower because the fans are rarely at full speed.

IMPROVED LIFECYCLE

Ecosmart enables the fan or air handling unit to be run at lower speeds. This reduces the maximum load and wear and therefore increases the overall working life of the units.

DEMAND VENTILATION

Only ventilates the area when you want it to - why fully ventilate a room when it's not occupied - maximum savings possible achieved.

HEALTHY ATMOSPHERE

Ecosmart has a trickle function as standard which when activated, via a simple switch, enables you to set a background ventilation rate, keeping the rooms fresh when unoccupied, whilst still saving

energy. System will boost or ramp to maximum design duty when triggered by an Ecosmart or other external device.

PLUG IN CONTROLS

Simple low voltage sensors complete with pre-plugged cable means that any control function is easily achieved. You decide which conditions to monitor and the system will operate at the optimum speed.

BMS INTERFACE

Integrated BMS features enable any central system to control and monitor the fan or air handling unit via 0-10V signal. This enables full speed control and heating or cooling enable if installed and volt free status indication as standard.

PEACE OF MIND

Ecosmart has a 5 year warranty. 1st year Parts and Labour with remaining years parts only. For further details contact Nuaira.

DAVE EXTRACT FANS ECOSMART CONTROLS



ECOSMART INCLUDES A WIDE RANGE OF OPTIONS

Simple SELV wired, plug-in 'enablers' start and stop the fan, when activated from either start-up or trickle ventilation mode. These 'enablers' include time clocks, infra-red detectors, switch live contacts, humidistats, thermostats and BMS contacts.

All systems must include at least one enabler. (NB. When used, BMS control and time clocks take over all other enablers).

Integrated speed control (inverter or electronic) is included with all Ecosmart controlled fans. ES-ISC are external to some fans and need to be hard wired.

Once the fan is activated by the enabler the sensor takes over. They will maintain comfort/ design conditions by automatically adjusting fan speed up and down. The sensors include temperature, relative humidity, CO₂ or as determined by the BMS.

Stylish and simple to operate user control facilitates manual operation where desired.



BMS

0-10V dc signal to activate the system and modulate fan speed. Select/Deselect H&C.
Note: this will override any other devices (eg. ES-UCF) fitted (except in Constant Pressure fans).

ECOSMART ENABLERS & DETECTORS

Simple Plug-in System

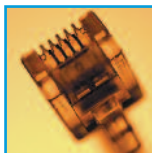

ES-PIR2 (Passive Infra-Red)

Detects movement and activates system. Incorporates a system status LED, overrun timer and timer adjustment.



ES-LCD

Touch screen user control in white incorporating time clock facility. This can control the function of the fan by manual setting or using a set of timed programs.



ES-HUMIDISTAT2

Activates the system when the RH level is above set point. Incorporates two system status LEDs (Green = OK, Red = Failure) and RH set point level adjustment.



ES-THERMOSTAT2

Activates the system when the temperature is above set point. Incorporates two system status LEDs (Green = OK, Red = Failure) and temperature set point level adjustment.



ES-AVIZ

When fan failure occurs the AVI will flash a warning. Supplied with pre-plugged 10m length of communication cable.



ES-CO2RM ES-CO2RMPP

Surface mounted room carbon dioxide (CO₂) sensors which incorporate a temperature sensor. RM = SELV option, RMPP complete with SELV AC powers supply.



ES-HTCSIG

Signal conditioning circuit for humidity, temperature and CO₂ sensors.

ECOSMART SPEED CONTROLLING SENSORS



ES-TEMP2 Temperature Sensor

Modulate fan speed based on room temperature. Incorporates two system status LEDs (Green = OK, Red = Failure) and temperature set point level adjustment.



ES-RH2 Relative Humidity Sensor

Modulate fan speed based on RH level. Incorporates two system status LEDs (Green = OK, Red = Failure) and RH set point level adjustment.



ES-UCF Manual user control

Manual 'on' and 'off' system user/speed control. Incorporates two system status LEDs (Green = OK, Red = Failure).

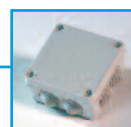

ES-CI Semi-automatic user control

Fan, heating & cooling selected by external volt free switch, speed selected by 0-10V signal.

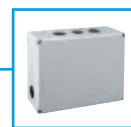

ES-JB Junction box

Designed to be compatible with Ecosmart System this unit is supplied with a pre-plugged 10 metre length of communications cable and has 8 further ports.



ES-CO2 Sensor

Duct mounted sensor to modulate fan speed based on CO₂ levels. Connect to fan directly. Pre-wired with 2m cable (not adjustable).



Switched Live by others

Any mains voltage signal connected to the switched live terminal (S/L) in the unit. This affects the connected fan only.

DAVE EXTRACT FANS

DAVE EXTRACT IS A COMPACT RANGE OF HIGH PERFORMANCE FANS IN 7 CASE SIZES. Including 9 duty curves (2 models providing High Static Pressure).

All models feature the Nuair patented 'Floating fan' design negating the requirement for further AV mounts.

Fans are single skinned construction and manufactured from aluzinc which lasts 5 times longer than galvanised steel and provides higher wear resistance.

Fans can be mounted in any position. All extract fans can be installed internally or externally without the requirement for additional weather protection.

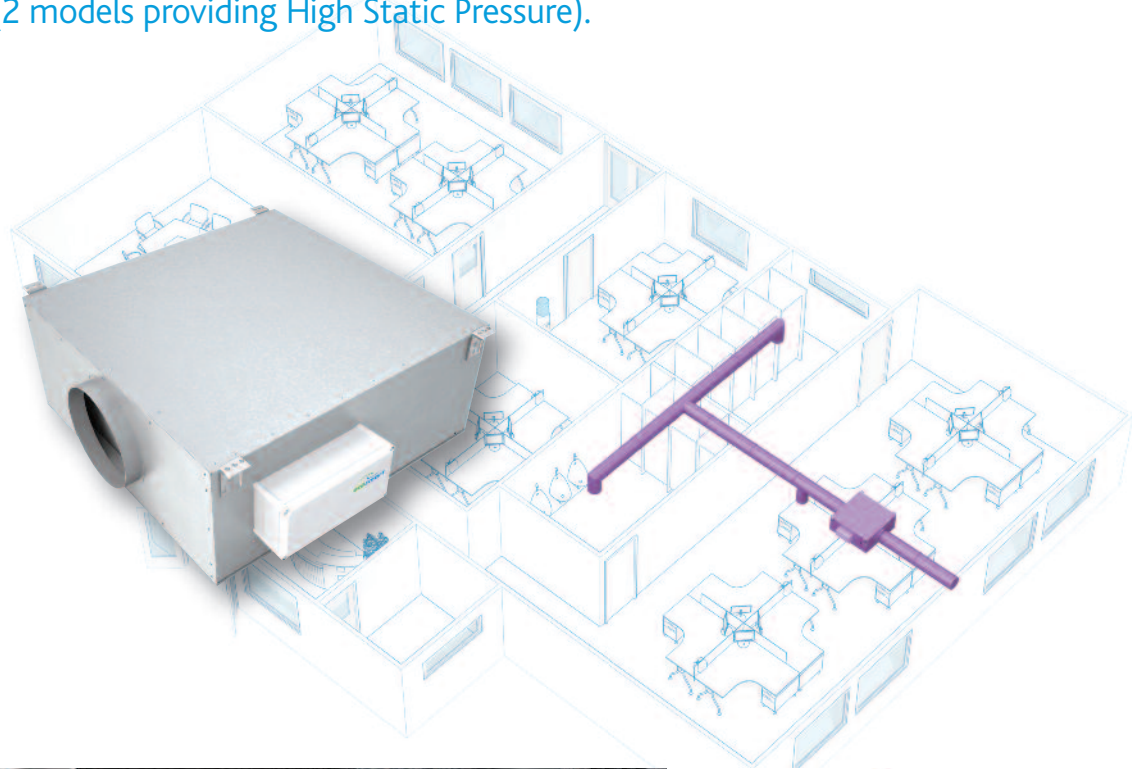

FEATURES AND BENEFITS

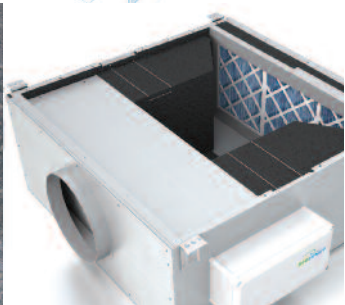
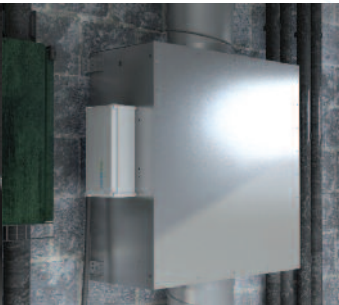
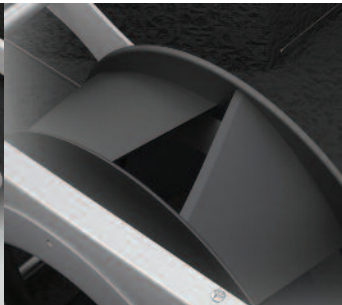
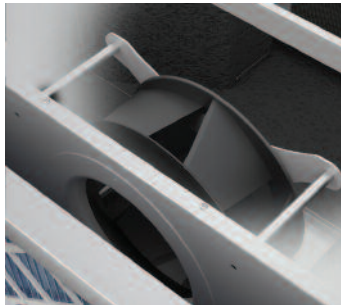

▲ **Patented Floating Fan.** Units are constructed using the Nuair 'Patented' floating fan technology which incorporates an inner casing held inside an outer casing by AV mounts, ensuring any vibration is isolated. This construction removes requirement for additional AV mounts.

▲ **Latest EC Technology.** Performance optimised backward curved impellers and IP54 EC motors provide low specific fan powers and stepless speed control without tonal noise generation.

▲ **Flexible orientation.** Extract fans can be installed in any orientation as standard.

▲ **Multi access.** Compact range ideal for space restricted applications such as ceiling voids. Units have top or bottom access as standard allowing for quick install and easy access to fans for maintenance. Model shown: (DE3A-ES).



▲ **Energy efficient 'Plug and Play' control.** Ecosmart energy efficient control with pre-programmed soft start function helps prevent electrical overloading and minimises mechanical wear. Weatherproof control cover included (if required).

▲ **Attenuation Pods.** Extract fans are single skin and lined with high density acoustic lining. Units* are fitted with attenuated pods to ensure low breakout noise levels. *Applies to Plus models only.

▲ **Quick & easy installation.** Fans are supplied with a set of support brackets for quick and easy installation into an existing drop rod system.

▲ **One solution.** A robust casing design ensures that all units are suitable for internal or external mounting as standard.



DAVE EXTRACT FANS SUMMARY SPECIFICATION

TO HELP YOU SELECT THE APPROPRIATE SOLUTION FOR YOUR EXTRACT APPLICATION, **[SIMPLY REFER TO THE OPTIONS BELOW.](#)**

For details on ancillaries refer to pages 41 - 44.

- Standard
- ▼ Optional
- ✘ Not Available

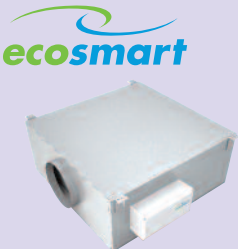
*Add relevant unit size 1 - 7.

	DAVE EXTRACT	DAVE EXTRACT PLUS
	 CODE: DE*-ES	 CODE: DE*A-ES
UNIT SPECIFICATION		
Aluzinc Case	●	●
Suitable for internal/external applications	●	●
High Performance EC fan	●	●
Patented Floating Fan Design	●	●
Built-in AV Mounts	●	●
Standard Lined Case	●	✘
Extended Lined Case	✘	●
Integrated Attenuation Pods	✘	●
G3 Filter	✘	●
Circular Spigot	●	●
Top or Bottom Access	●	●
Powder Coated Option (contact Nuaire)	▼	▼
FAN ANCILLARIES		
Fast Clamps (Example: FC-150)	▼	▼
Circular Flexible Connector (Example: CFC16)	▼	▼
Silencer internal (SIL-150)	▼	▼
Silencer external (CA25L)	▼	▼
Anti-vibration mounts (NAV 2)	▼	▼
CONTROL SPECIFICATION		
Ecosmart Energy Efficient Plug & Play Control	●	●
ECOSMART ANCILLARIES/ENABLERS (ON/OFF)		
ES-PIR2	▼	▼
ES-LCD (Touch screen)	▼	▼
ES-HUMIDISTAT2	▼	▼
ES-THERMOSTAT2	▼	▼
ES-AVI2 (Audio visual indicator)	▼	▼
ES-CO2RM/ES-CO2RMPP (Room mounted)	▼	▼
ES-HTCSIG (Signal conditioning circuit)	▼	▼
ECOSMART ANCILLARIES/CONTROLLING (SENSORS)		
ES-TEMP2	▼	▼
ES-RH2	▼	▼
ES-UCF (Manual control)	▼	▼
ES-CO2 (Duct mounted)	▼	▼
ES-CI (Control interface)	▼	▼
ES-JB (Junction box)	▼	▼
ES-CO2RM/ES-CO2RMPP (Room mounted)	▼	▼
NOTE: All systems must include at least one enabler (N.B. when used, BMS control and time clocks take over all other enablers).		

DAVE EXTRACT FANS CONSULTANTS SPECIFICATION

UNIT SPECIFICATION

The Unit shall be configured and arranged as detailed on the drawings and in accordance with the schedule of equipment.

Units have a patented 'Floating Fan' technology incorporating an inner casing which is held inside an outer casing by AV mounts, ensuring any vibration is isolated. This technology eliminates the requirement for additional AV mounts.

The units are manufactured in two case lengths – Standard or Type 'A' Extended. Units shall be manufactured from acoustically lined, heavy gauge, corrosion resistant aluzinc and tested to leakage class 'L2'.

The unit will be manufactured to provide a low height solution to enable it to be located in low depth ceiling and floor voids. The units shall have a maximum depth of 233/300/345/370/410/455/500mm (models DE1-7). For ease of installation the unit shall be supplied complete with 4 mounting brackets for inclusion into a drop rod mounting system.

Impellers shall be of high efficiency, performance and sound optimised backward curved design.

The unit shall be fitted with ErP 2015 rated, low energy, high efficiency IP54 EC motorised fans providing low specific fan powers and stepless speed control without tonal noise generation. Fan/motor assemblies have sealed for life bearings with an anticipated working life of 70,000 hours (L10) and shall be suitable for single phase supply. Units are suitable for operation in ambient temperatures of up to 60°C (unit sizes 1 - 5) and up to 40°C (unit sizes 6 - 7).

The unit and ancillaries shall be of the DAVE Extract type as manufactured by Nuaire Ltd

INSTALLATION

By the appointed contractor. The DAVE extract fan can be installed internally or externally as standard without the requirement for additional weather protection. The extract range can be mounted in any orientation refer to manufacturers installation and maintenance manual for details. Mechanical installation requires mounting of the extract unit in the designated position and connection to the associated duct work. Either top or bottom access is available as standard. Electrical installation requires the provision and connection of single phase electrical supply at the fan.

INSTALLATION REQUIREMENTS

The mechanical contractor shall ensure that all necessary ancillaries are included eg. flexible connections, attenuators, etc. The contractor shall allow for all necessary ductwork transformations to and from the fan unit and any associate components in accordance with the manufacturer's recommendations, DW 144 and general good practice.

RANGE MODELS

DAVE Extract: Standard lined case. Energy efficient Ecosmart control. Circular spigots.

DAVE Extract Plus: Extended lined case type 'A', G3 filter, attenuation pods, Energy efficient Ecosmart control. Circular spigots.

CODE DESCRIPTION

DE1-ES



1 2 3 4

1. DAVE Range
2. Extract fan
3. Case size standard size (1-7)
4. ES = Ecosmart control

DE4HA-ES



1 2 3 4 5 6

1. DAVE Range
2. Extract fan
3. Case size (1-7)
4. H = High pressure fan (Size 2 & 4 only)
5. Case type: A = Extended
6. ES = Ecosmart control

CONTROL SPECIFICATION

The fan unit shall be supplied with the following control:-

ECOSMART – DEMAND CONTROLLED VENTILATION

Provides the facility for energy saving via an intelligent function with local diagnostics status indication, or allows convenient integration with the client BMS with a minimal co-ordination requirement. The factory fitted Ecosmart control panel mounted to the fan unit includes: integral infinitely variable speed /duty control for the extract fan, with independent minimum, maximum speed adjustment for accurate commissioning. The control assembly is side mounted with a removable weather control fascia (if required).

The Ecosmart control enables the fan's speed to be varied automatically as conditions in the ventilated space change by linking low voltage sensors or as the low voltage user control is adjusted. It also enables multiple fans to be directly interlinked. The user control (ES-LCD) and low voltage sensor are supplied complete with a 10m length of low voltage, pre-plugged cable. The control features a run on timer and "background" ventilation function, and is provided with unit status indication, run and fail relays and interface connections for Ecosmart sensors and enablers.

The fans shall have the following energy saving and operational functions integrally installed within it, all components will be pre-wired and fitted by the manufacturer:

- Integral frequency inverter/speed controller
- Integral adjustable run-on timer
- Maximum and minimum speed adjustment/setting (trickle and boost)
- Volt free run & failure/status indication
- 0-10V BMS interface for remote operation
- Low voltage interface with second fan or supply fan
- Multiple low voltage sockets for interconnection of sensors or fans
- Background ventilation/trickle enable switch.

Fan, Ecosmart controls and associated sensors/ controllers shall be manufactured by Nuaire Ltd. Units fitted with Ecosmart control (code example DE3-ES) shall have a 5 year warranty.



DAVE Extract
Specification
Document.

DAVE EXTRACT FANS WIRING

WIRING CONNECTIONS FOR UNITS WITH ECOSMART CONTROL

a) Mains connections.

Mains cables should be suitably sized and terminated at terminals shown on the appropriate diagram.

b) Control Connections.

Below: 'Net' connection for Ecosmart devices.

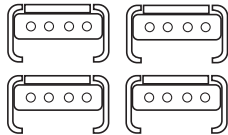

Net - the 4 IDC plug-in connectors are provided for the connection of compatible sensors, manual controls and for linking the fans together under a common control. If more than 4 connections are required, the junction box (product code ES-JB) should be used (see data cable installation).

c) Switched Live (SL) terminal.

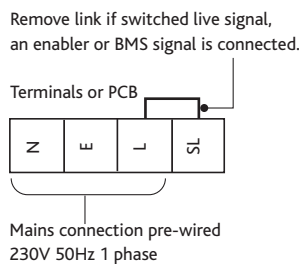

A signal of 100-230V a.c. will activate the fan from either its off state or trickle state (see setting to work-trickle switch). When the SL is disconnected the fan will over-run (see setting to work-timer adjustment). Do not take this signal from an isolating transformer.

d) Volt Free Relay Contacts.

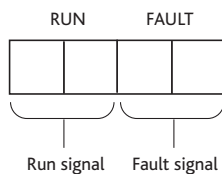

LED INDICATION FOR UNITS WITH ECOSMART CONTROL

- PWR** GREEN: Power on & OK. RED: To much power is taken by peripherals or there is a short circuit in the net cable. Check the cable and use a junction box (ES-JB) to connect some of the peripherals.
- Standby** LED on when fan is not running.
- Fan 1** GREEN: Fan 1 is running, RED: Fan 1 faulty.
- Fan 2** GREEN: Fan 2 is running, RED: Fan 2 faulty. (Twin fan only)
- Heating*** Not applicable. See note.
- Cooling*** Not applicable. See note.
- Fault** LED on when a fault is present on unit.
- Frost*** Not applicable. See note.
- Tx** LED on when the controller is transmitting data.
- Rx** LED on when the controller is receiving data.

* Note that the control panel is common to all the Ecosmart products and will have indicators for functions that are not available in this particular fan. However these indicators will not be illuminated.

e) Commissioning panel details.

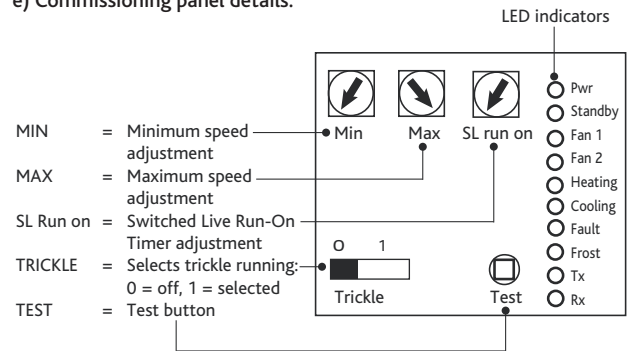

Note: A Commissioning Procedure document is available on request from Nuaire.

THE CONTROL MODULE

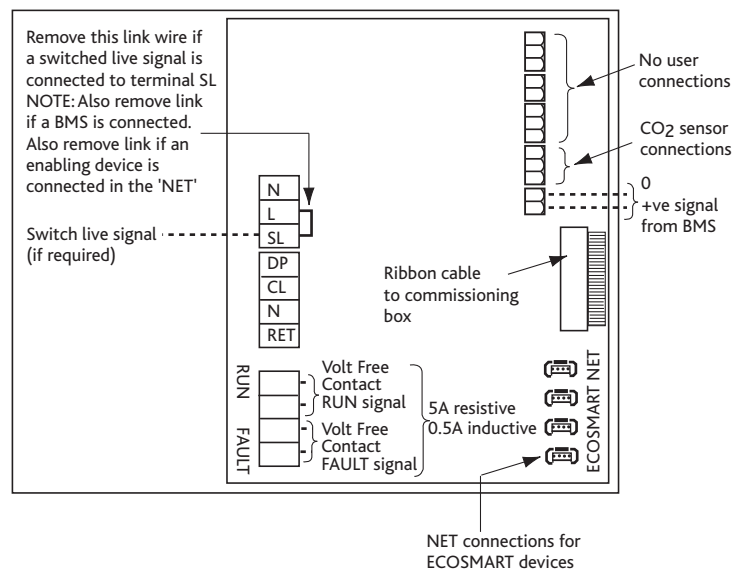

For good EMC engineering practice, any sensor or low voltage data cables should not be placed within 50mm of mains cables or placed on the same cable tray or conduit as mains cables.

COMPLYING WITH BUILDING REGULATIONS

The following information is relevant to the selection of fans for Ventilation Systems, indicating the maximum specific fan powers allowed under Part L (Refer to the Non-domestic Building Services Compliance Guide: 2013 Edition for further details).



The SFP for the entire system (including both supply & extract fans) shall be less than that allowed by these figures. The following tables are the maximum values allowed under Building Regulations when finally commissioned.

Air distribution system	Specific fan power (W/(l/s))	
	New Buildings	Existing Buildings
Central balanced mechanical ventilation system with heating and cooling	1.6	2.2
Central balanced mechanical ventilation system with heating only	1.5	1.8
All other central balanced mechanical ventilation systems	1.1	1.6
Zonal supply system where the fan is remote from the zone, such as ceiling void or roof mounted units	1.1	1.4
Zonal extract system where fan is remote from zone	0.5	0.5
Zonal supply and extract ventilation system such as ceiling void or roof units serving a single room or zone with heating and heat recovery	1.9	1.9
Local balanced supply and extract ventilation system / such as wall roof units serving a single area with heating and heat recovery	1.6	1.6
Local supply or extract ventilation units such as window / wall / roof units serving a single area (e.g. toilet extract)	0.3	0.4
Other local ventilation supply or extract units	0.5	0.5
Fan assisted terminal (VAV) unit	1.1	1.1
Fan coil units (rating weighted average*)	0.5	0.5
Kitchen extract, fan remote from zone with grease filter	1.0	1.0

*Note: The weighted average is calculated by the following formula:

$$\frac{P_{\text{mains},1} \cdot \text{SFP}_1 + P_{\text{mains},2} \cdot \text{SFP}_2 + P_{\text{mains},3} \cdot \text{SFP}_3 + \dots}{P_{\text{mains},1} + P_{\text{mains},2} + P_{\text{mains},3} + \dots}$$

where P_{mains} is useful power supplied from the mains in W

SECTION 6

Permissible maximum specific fan power and pressure drop in air distribution systems.



Air distribution system	Maximum permissible specific fan power (W/(l/s))	Maximum external system pressure drop (Pa)
Central mechanical ventilation system including heating, cooling and heat recovery	1.8	400 supply 250 extract
Central mechanical ventilation system including heating and cooling	1.8 (2.2)	400 supply 250 extract
Central mechanical ventilation system including heating only	1.6 (1.6)	400 supply 250 extract
All other central mechanical ventilation systems	1.4 (1.8)	400 supply 250 extract
Zonal supply system where the fan is remote from the zone, such as ceiling void or roof mounted units	1.2 (1.5)	200
Zonal extract system where the fan is remote from the zone	0.6 (0.6)	200
Zonal supply and extract ventilation units such as ceiling void or roof units serving a single room or zone with heating and heat recovery	2.0 (2.0)	150
Local supply and extract ventilation system such as wall / roof units serving a single area with heating and heat recovery	1.8 (1.8)	150
Local supply or extract ventilation units such as window / wall / roof units serving a single area (e.g. toilet extract)	0.4 (0.5)	30
Other local ventilation units	0.6 (0.6)	30
Fan assisted terminal variable air volume (VAV) unit	1.2 (1.2)	30
Fan coiled units	0.6 (0.6)	30

Note: 1. For existing buildings the maximum permissible specific fan power is given in brackets.

Extending SFP for additional components in new and existing buildings

Component	(SFP (W/(l/s)))
Additional return filter for heat recovery	+0.1
HEPA filter	+1.0
Heat recovery - thermal wheel system	+0.3
Heat recovery - other systems	+0.3
Humidifier / dehumidifier (air conditioning system)	+0.1

Example: For a central mechanical ventilation system with heating and cooling, and heat recovery via a plate heat exchanger plus return filter:

$$\text{SFP} = 1.6 + 0.3 + 0.1 \text{ W/(l/s)} \\ = 2.0 \text{ W/(l/s)}$$

Recommended minimum dry heat recovery efficiency for heat exchangers in new and existing buildings

Heat exchanger type	Dry Heat recovery efficiency
Plate heat exchanger	50%
Heat pipes	60%
Thermal wheel	65%
Run around coil	45%

DAVE EXTRACT FANS (SIZE DE1 UNIT)

PERFORMANCE & TECHNICAL INFORMATION

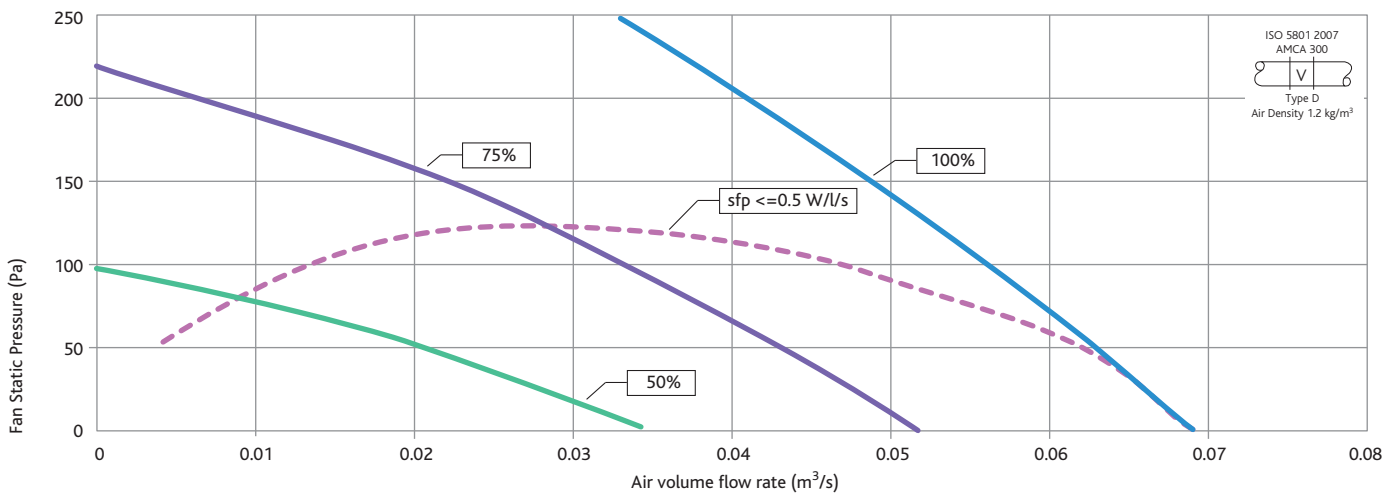

EXTRACT FAN SIZE DE1 - PERFORMANCE

Fan Speed	External Static Pressure (Pa)						
	0	50	100	150	200	250	
100%	Airflow (m ³ /s)	0.069	0.063	0.056	0.049	0.041	0.033
	SFP (W/l/s)	0.459	0.511	0.582	0.676	0.817	1.024
75%	Airflow (m ³ /s)	0.0518	0.043	0.033	0.022	0.006	
	SFP (W/l/s)	0.258	0.320	0.423	0.648	2.363	
50%	Airflow (m ³ /s)	0.034	0.02				
	SFP (W/l/s)	0.115	0.204				

For accurate figures, please refer to Nuair Fan Selection Programme at www.nuair.co.uk, alternatively call Nuair on (029 2085 8200).

Unit Code	Voltage/phase Frequency	Input Power (kW)	FLC/SC (A)	Fan Speed (RPM)	Unit Weight (kg)	Packed Weight (kg)	Pallet/Crate Dimensions (mm)
DE1-ES	230 / 1 / 50	0.03	0.27 / 0.27	3770	25	30.5	800 L x 1000 W x 389 H
DE1A-ES	230 / 1 / 50	0.03	0.27 / 0.27	3770	30	35.5	1200 L x 1000 W x 389 H

EXTRACT FAN SIZE DE1 - SOUND DATA

Unit Code		Sound Power Levels dB re 1pW								Breakout dBA @ 100% @ 3m	LwA	Breakout dBA @ 75% @ 3m	Breakout dBA @ 50% @ 3m
		63	125	250	500	1K	2K	4K	8K				
DE1-ES	Induct Inlet	71	62	63	53	51	46	45	43	22	59	16	<16
	Induct Outlet	73	66	68	62	56	51	50	44		64		
	Breakout	53	52	46	42	31	28	25	12		43		
DE1A-ES	Induct Inlet	70	56	55	41	37	36	40	35	17	51	<16	<16
	Induct Outlet	73	67	62	57	53	50	50	44		61		
	Breakout	52	50	39	34	23	23	22	7		38		

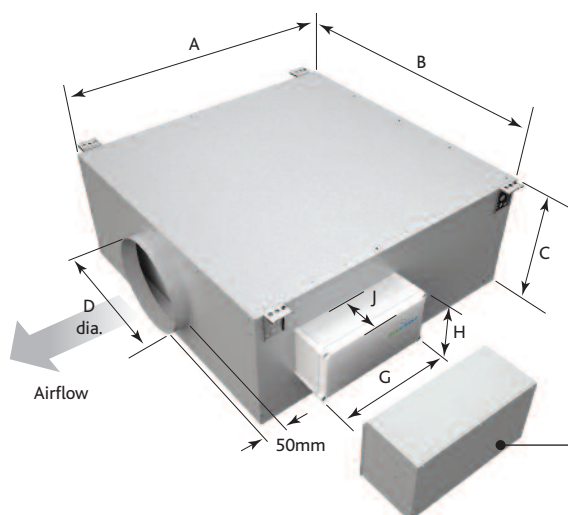

EXTRACT FAN SIZE DE1 - DIMENSIONS (mm)

Unit Code	Ecosmart control						
	A	B	C	D (Dia)	G	H	J
DE1-ES	605	559	233	150	370	150	100
DE1A-ES	1005	559	233	150	370	150	100

Access for Maintenance: Allow 233mm either above or below the unit.

For control box access allow a minimum clearance of 600mm from a wall or barrier.

Removable weatherproof control cover (if required).
Dimensions: 470mm wide x 173mm high x 120mm deep.

DAVE EXTRACT FANS (SIZE DE2 UNIT)

PERFORMANCE & TECHNICAL INFORMATION

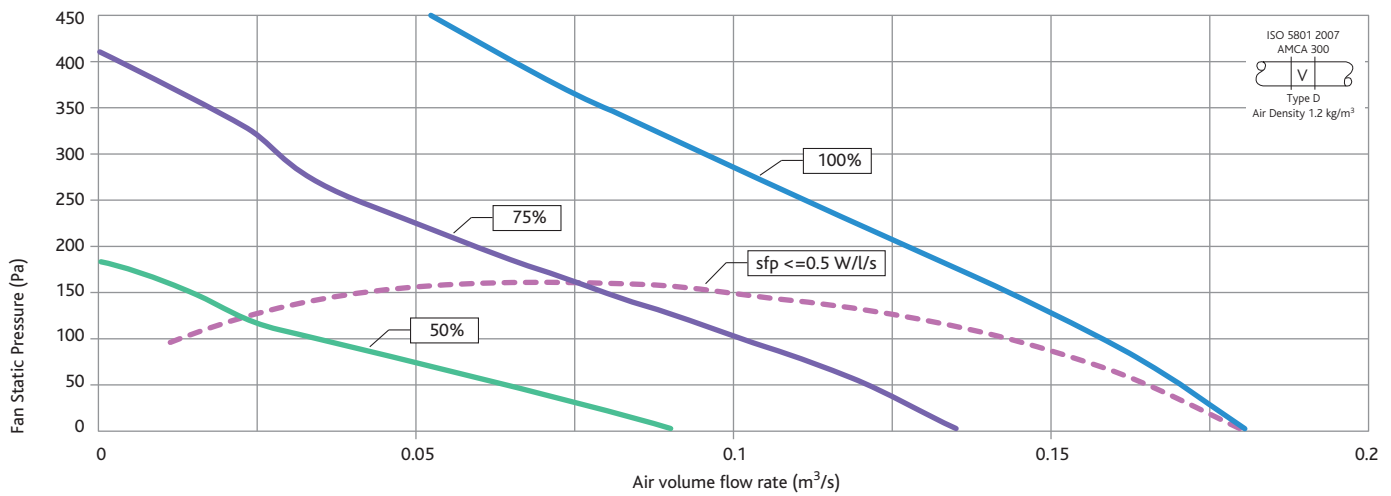

EXTRACT FAN SIZE DE2 - PERFORMANCE

Fan Speed	External Static Pressure (Pa)					
	0	100	200	300	400	
100%	Airflow (m ³ /s)	0.181	0.158	0.127	0.095	0.065
	SFP (W/l/s)	0.492	0.563	0.702	0.939	1.368
75%	Airflow (m ³ /s)	0.136	0.1	0.058	0.028	
	SFP (W/l/s)	0.277	0.395	0.770	1.780	
50%	Airflow (m ³ /s)	0.091	0.032			
	SFP (W/l/s)	0.123	0.342			

For accurate figures, please refer to Nuair Fan Selection Programme at www.nuair.co.uk, alternatively call Nuair on (029 2085 8200).

Unit Code	Voltage/phase Frequency	Input Power (kW)	FLC/SC (A)	Fan Speed (RPM)	Unit Weight (kg)	Packed Weight (kg)	Pallet/Crate Dimensions (mm)
DE2-ES	230 / 1 / 50	0.088	0.75 / 0.75	3200	25	30.5	800 L x 1000 W x 456 H
DE2A-ES	230 / 1 / 50	0.088	0.75 / 0.75	3200	40	45.5	1200 L x 1000 W x 456 H

EXTRACT FAN SIZE DE2 - SOUND DATA

Unit Code		Sound Power Levels dB re 1pW								Breakout dBA @ 100% @ 3m	LwA	Breakout dBA @ 75% @ 3m	Breakout dBA @ 50% @ 3m
		63	125	250	500	1K	2K	4K	8K				
DE2-ES	Induct Inlet	70	66	61	59	55	53	54	52	24	62	18	<16
	Induct Outlet	74	67	67	59	57	58	54	54		65		
	Breakout	56	50	47	42	37	36	34	30		45		
DE2A-ES	Induct Inlet	70	62	58	47	42	43	45	43	21	54	<16	<16
	Induct Outlet	78	78	61	57	57	58	54	54		66		
	Breakout	58	53	43	35	35	31	30	26		42		

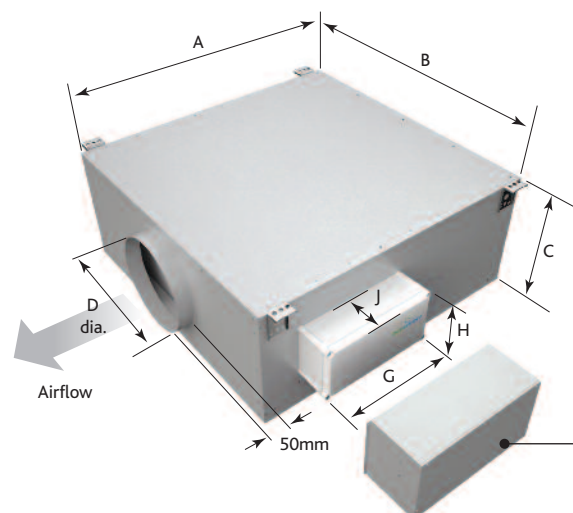

EXTRACT FAN SIZE DE2 - DIMENSIONS (mm)

Unit Code	A	B	C	D (Dia)	Ecosmart control		
	G	H	J				
DE2-ES	605	696	300	200	370	150	100
DE2A-ES	1005	696	300	200	370	150	100

Access for Maintenance: Allow 300mm either above or below the unit.
For control box access allow a minimum clearance of 600mm from a wall or barrier.

Removable weatherproof control cover (if required).
Dimensions: 470mm wide x 173mm high x 120mm deep.

DAVE EXTRACT FANS (SIZE DE2H UNIT)

PERFORMANCE & TECHNICAL INFORMATION

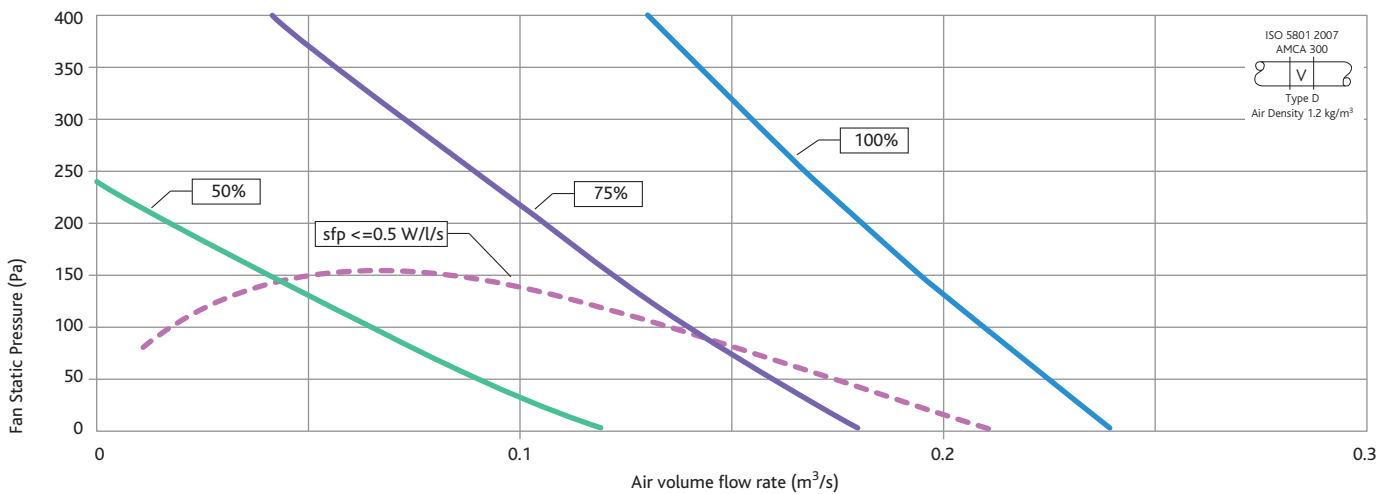

EXTRACT FAN SIZE DE2H - PERFORMANCE

Fan Speed	External Static Pressure (Pa)					
	0	200	400			
100%	Airflow (m ³ /s)	0.24	0.18	0.13		
	SFP (W/l/s)	0.643	0.948	1.317		
75%	Airflow (m ³ /s)	0.18	0.105	0.04		
	SFP (W/l/s)	0.361	0.740	0.740		
50%	Airflow (m ³ /s)	0.12	0.018			
	SFP (W/l/s)	0.161	1.230			

For accurate figures, please refer to Nuair Fan Selection Programme at www.nuaire.co.uk, alternatively call Nuair on (029 2085 8200).

Unit Code	Voltage/phase Frequency	Input Power (kW)	FLC/SC (A)	Fan Speed (RPM)	Unit Weight (kg)	Packed Weight (kg)	Pallet/Crate Dimensions (mm)
DE2H-ES	230 / 1 / 50	0.17	1.4 / 1.4	4060	25	30.5	800 L x 1000 W x 456 H
DE2HA-ES	230 / 1 / 50	0.17	1.4 / 1.4	4060	45	50.5	1200 L x 1000 W x 456 H

EXTRACT FAN SIZE DE2H - SOUND DATA

Unit Code		Sound Power Levels dB re 1pW								Breakout dBA @ 100% @ 3m	LwA	Breakout dBA @ 75% @ 3m	Breakout dBA @ 50% @ 3m
		63	125	250	500	1K	2K	4K	8K				
DE2H-ES	Induct Inlet	77	73	69	71	62	61	61	66	30	72	24	<16
	Induct Outlet	81	74	74	68	67	66	62	64		73		
	Breakout	58	59	48	50	44	41	37	34		51		
DE2HA-ES	Induct Inlet	75	67	63	54	49	51	53	54	25	61	19	<16
	Induct Outlet	75	82	67	64	63	66	62	65		59		
	Breakout	53	60	42	40	36	36	33	29		46		

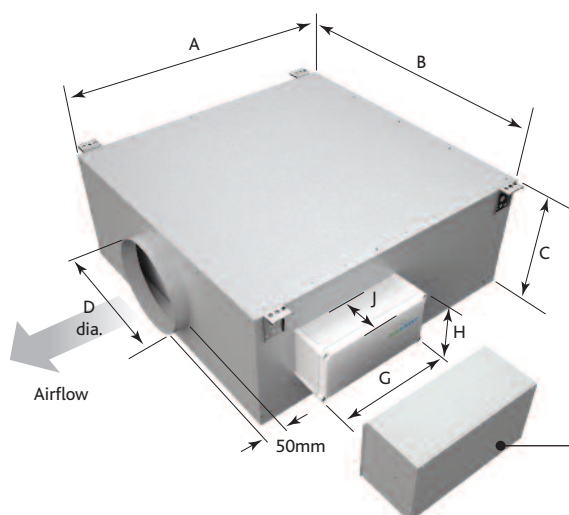

EXTRACT FAN SIZE DE2H - DIMENSIONS (mm)

Unit Code	A	B	C	D (Dia)	Ecosmart control		
					G	H	J
DE2H-ES	605	696	300	200	370	150	100
DE2HA-ES	1005	696	300	200	370	150	100

Access for Maintenance: Allow 300mm either above or below the unit.

For control box access allow a minimum clearance of 600mm from a wall or barrier.

Removable weatherproof control cover (if required).
Dimensions: 470mm wide x 173mm high x 120mm deep.

DAVE EXTRACT FANS (SIZE DE3 UNIT)

PERFORMANCE & TECHNICAL INFORMATION

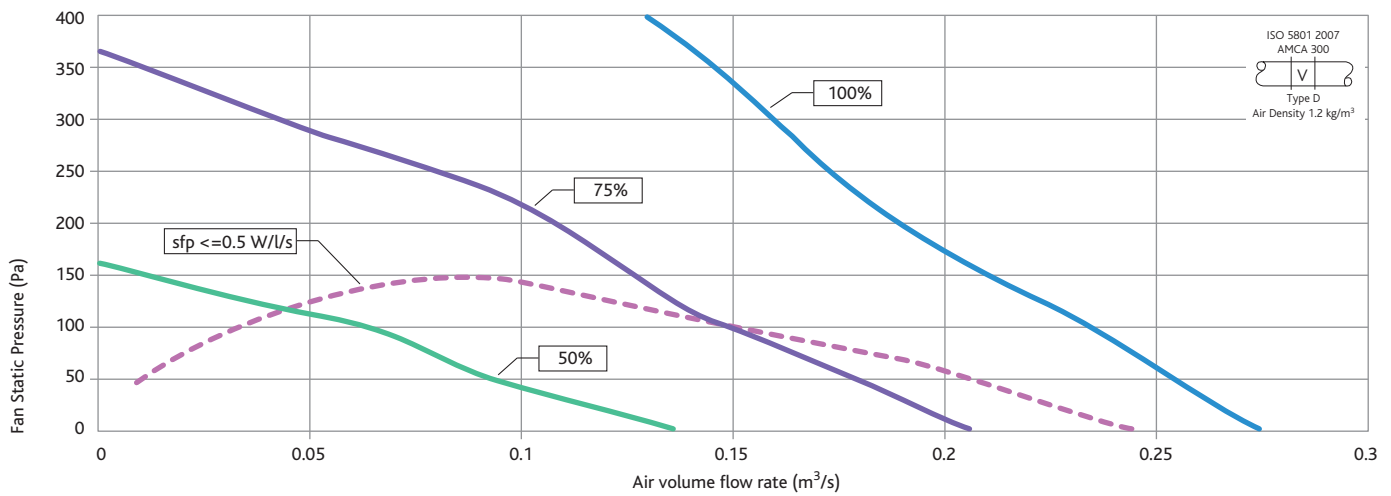

EXTRACT FAN SIZE DE3 - PERFORMANCE

Fan Speed	External Static Pressure (Pa)					
	0	100	200	300	400	
100%	Airflow (m ³ /s)	0.275	0.235	0.19	0.16	0.13
	SFP (W/l/s)	0.631	0.743	0.916	1.090	1.335
75%	Airflow (m ³ /s)	0.206	0.15	0.11	0.04	
	SFP (W/l/s)	0.355	0.515	0.750	3.910	
50%	Airflow (m ³ /s)	0.138	0.065			
	SFP (W/l/s)	0.158	0.334			

For accurate figures, please refer to Nuair Fan Selection Programme at www.nuair.co.uk, alternatively call Nuair on (029 2085 8200).

Unit Code	Voltage/phase Frequency	Input Power (kW)	FLC/SC (A)	Fan Speed (RPM)	Unit Weight (kg)	Packed Weight (kg)	Pallet/Crate Dimensions (mm)
DE3-ES	230 / 1 / 50	0.17	1.4 / 1.4	2860	30	40	800 L x 1000 W x 501 H
DE3A-ES	230 / 1 / 50	0.17	1.4 / 1.4	2860	50	60	1200 L x 1000 W x 501 H

EXTRACT FAN SIZE DE3 - SOUND DATA

Unit Code		Sound Power Levels dB re 1pW								Breakout dBA @ 100% @ 3m	LwA	Breakout dBA @ 75% @ 3m	Breakout dBA @ 50% @ 3m
		63	125	250	500	1K	2K	4K	8K				
DE3-ES	Induct Inlet	80	77	62	66	59	57	58	57	34	68	28	19
	Induct Outlet	88	86	68	61	59	60	57	58		72		
	Breakout	62	69	57	49	42	37	29	25		55		
DE3A-ES	Induct Inlet	73	64	56	52	47	48	52	49	26	58	20	<16
	Induct Outlet	82	79	63	59	58	59	58	58		68		
	Breakout	56	60	51	41	36	32	26	21		47		

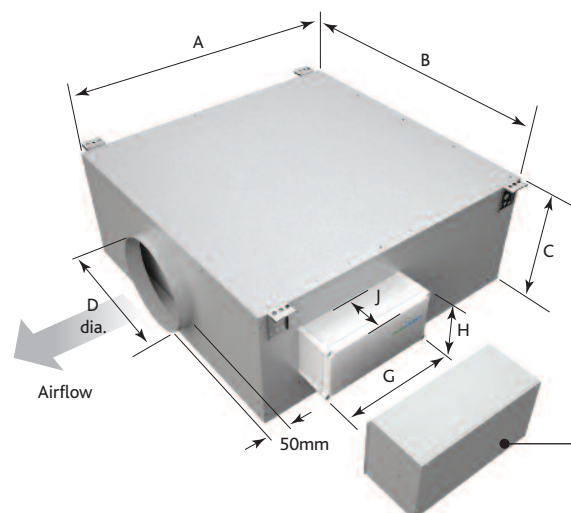

EXTRACT FAN SIZE DE3 - DIMENSIONS (mm)

Unit Code	A	B	C	D (Dia)	Ecosmart control		
	G	H	J				
DE3-ES	605	780	345	200	370	150	100
DE3A-ES	1005	780	345	200	370	150	100

Access for Maintenance: Allow 345mm either above or below the unit.
For control box access allow a minimum clearance of 600mm from a wall or barrier.

Removable weatherproof control cover (if required).
Dimensions: 470mm wide x 173mm high x 120mm deep.

DAVE EXTRACT FANS (SIZE DE4 UNIT)

PERFORMANCE & TECHNICAL INFORMATION

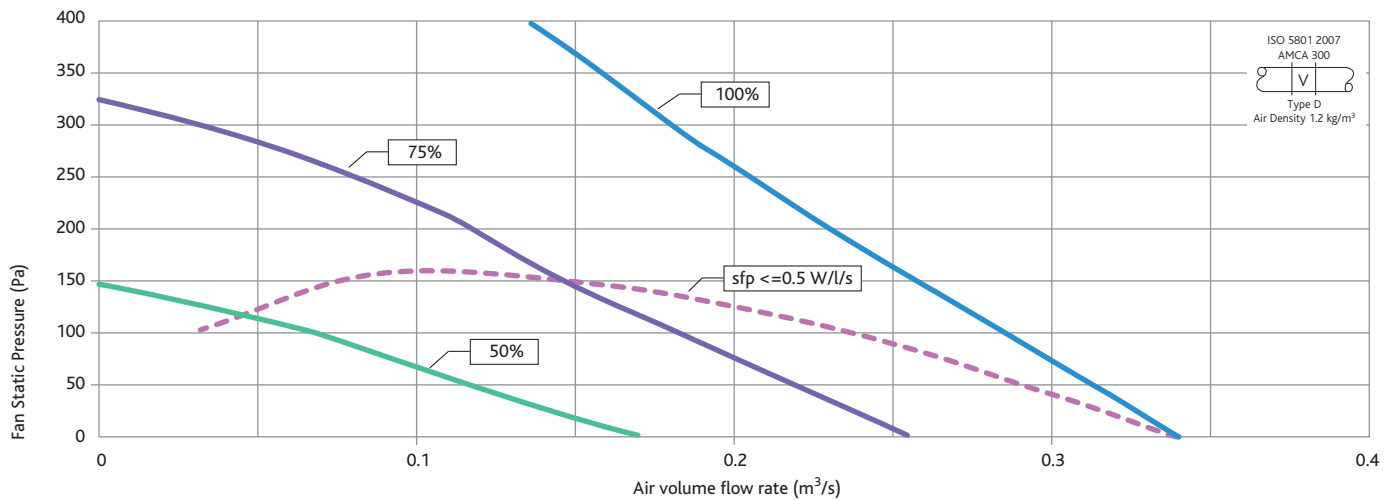

EXTRACT FAN SIZE DE4 - PERFORMANCE

Fan Speed	External Static Pressure (Pa)					
	0	100	200	300	400	
100%	Airflow (m ³ /s)	0.34	0.285	0.23	0.18	0.135
	SFP (W/l/s)	0.508	0.611	0.756	0.970	1.292
75%	Airflow (m ³ /s)	0.255	0.18	0.115	0.03	
	SFP (W/l/s)	0.286	0.425	0.727	2.430	
50%	Airflow (m ³ /s)	0.17	0.068			
	SFP (W/l/s)	0.127	1.323			

For accurate figures, please refer to Nuair Fan Selection Programme at www.nuair.co.uk, alternatively call Nuair on (029 2085 8200).

Unit Code	Voltage/phase Frequency	Input Power (kW)	FLC/SC (A)	Fan Speed (RPM)	Unit Weight (kg)	Packed Weight (kg)	Pallet/Crate Dimensions (mm)
DE4-ES	230 / 1 / 50	0.17	1.35 / 1.35	2550	35	45	800 L x 1200 W x 526 H
DE4A-ES	230 / 1 / 50	0.17	1.35 / 1.35	2550	67	77	1200 L x 1200 W x 526 H

EXTRACT FAN SIZE DE4 - SOUND DATA

Unit Code		Sound Power Levels dB re 1pW								Breakout dBA @ 100% @ 3m	LwA	Breakout dBA @ 75% @ 3m	Breakout dBA @ 50% @ 3m
		63	125	250	500	1K	2K	4K	8K				
DE4-ES	Induct Inlet	74	72	62	63	57	55	55	55	25	65	19	<16
	Induct Outlet	82	82	65	60	59	59	54	55		69		
	Breakout	57	56	48	43	38	34	28	24		46		
DE4A-ES	Induct Inlet	72	67	63	54	48	48	48	45	23	59	17	<16
	Induct Outlet	82	82	66	60	59	59	53	54		69		
	Breakout	57	54	49	39	33	30	24	19		44		

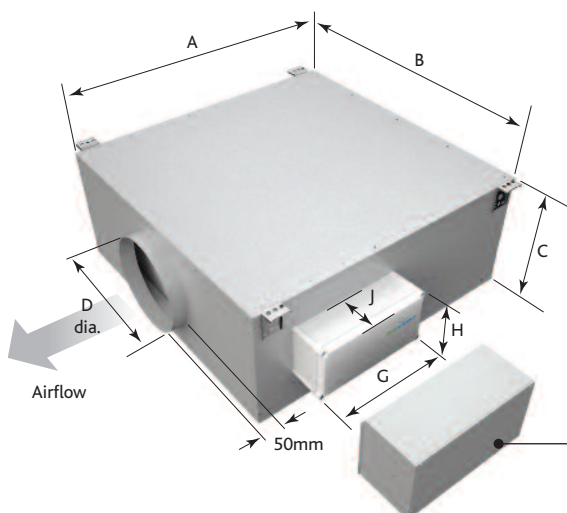

EXTRACT FAN SIZE DE4 - DIMENSIONS (mm)

Unit Code	Dimensions (mm)				Ecosmart control		
	A	B	C	D (Dia)	G	H	J
DE4-ES	605	840	370	250	370	150	100
DE4A-ES	1005	840	370	250	370	150	100

Access for Maintenance: Allow 370mm either above or below the unit.
For control box access allow a minimum clearance of 600mm from a wall or barrier.

Removable weatherproof control cover (if required).
Dimensions: 470mm wide x 173mm high x 120mm deep.

DAVE EXTRACT FANS (SIZE DE4H UNIT)

PERFORMANCE & TECHNICAL INFORMATION

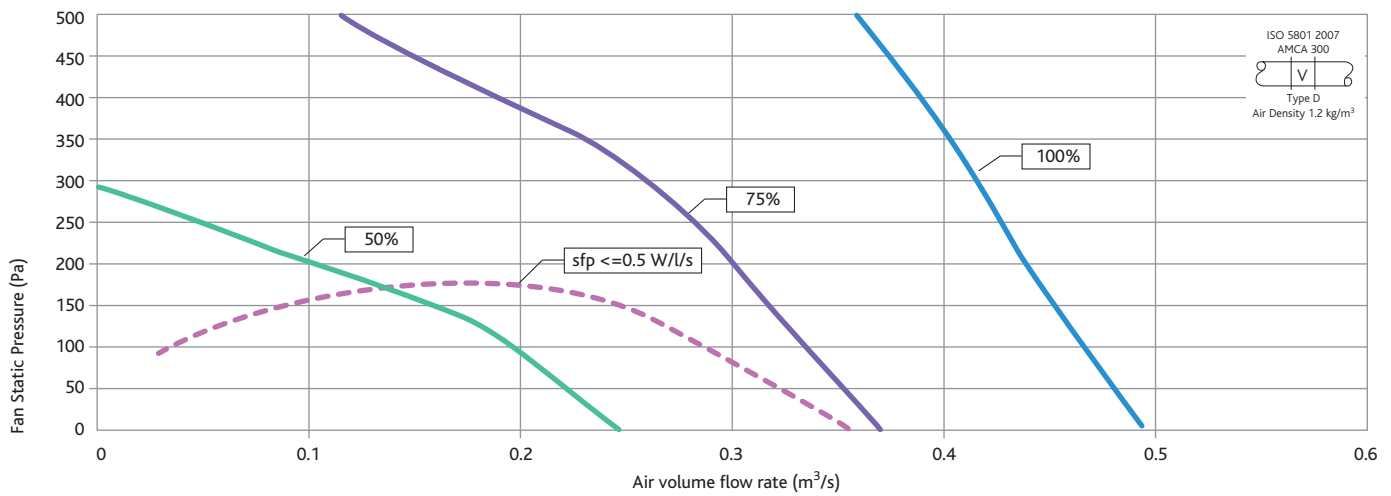

EXTRACT FAN SIZE DE4H - PERFORMANCE

Fan Speed	External Static Pressure (Pa)				
	0	200	400	600	
100%	Airflow (m ³ /s)	0.495	0.44	0.39	0.32
	SFP (W/l/s)	0.953	1.126	1.301	1.719
75%	Airflow (m ³ /s)	0.371	0.3	0.19	0.045
	SFP (W/l/s)	0.536	0.633	1.210	5.220
50%	Airflow (m ³ /s)	0.248	0.1		
	SFP (W/l/s)	0.238	0.679		

For accurate figures, please refer to Nuair Fan Selection Programme at www.nuair.co.uk, alternatively call Nuair on (029 2085 8200).

Unit Code	Voltage/phase Frequency	Input Power (kW)	FLC/SC (A)	Fan Speed (RPM)	Unit Weight (kg)	Packed Weight (kg)	Pallet/Crate Dimensions (mm)
DE4H-ES	230 / 1 / 50	0.49	2.2 / 2.2	3700	40	50	800 L x 1200 W x 526 H
DE4HA-ES	230 / 1 / 50	0.49	2.2 / 2.2	3700	67	77	1200 L x 1200 W x 526 H

EXTRACT FAN SIZE DE4H - SOUND DATA

Unit Code		Sound Power Levels dB re 1pW								Breakout dBA @ 100% @ 3m	LwA	Breakout dBA @ 75% @ 3m	Breakout dBA @ 50% @ 3m
		63	125	250	500	1K	2K	4K	8K				
DE4H-ES	Induct Inlet	82	81	69	78	69	68	65	71	37	78	31	22
	Induct Outlet	91	91	76	75	73	71	66	66		80		
	Breakout	66	65	56	58	51	46	39	38		58		
DE4HA-ES	Induct Inlet	80	76	70	67	59	61	58	61	34	70	28	19
	Induct Outlet	91	91	76	76	73	71	65	66		80		
	Breakout	65	63	57	53	45	43	35	33		55		

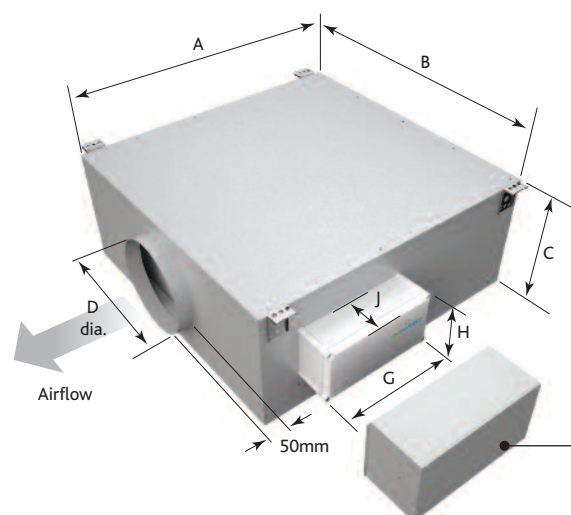

EXTRACT FAN SIZE DE4H - DIMENSIONS (mm)

Unit Code	A	B	C	D (Dia)	Ecosmart control		
	G	H	J				
DE4H-ES	605	840	370	250	370	150	100
DE4HA-ES	1005	840	370	250	370	150	100

Access for Maintenance: Allow 370mm either above or below the unit.

For control box access allow a minimum clearance of 600mm from a wall or barrier.

Removable weatherproof control cover (if required).
Dimensions: 470mm wide x 173mm high x 120mm deep.

DAVE EXTRACT FANS (SIZE DE5 UNIT)

PERFORMANCE & TECHNICAL INFORMATION

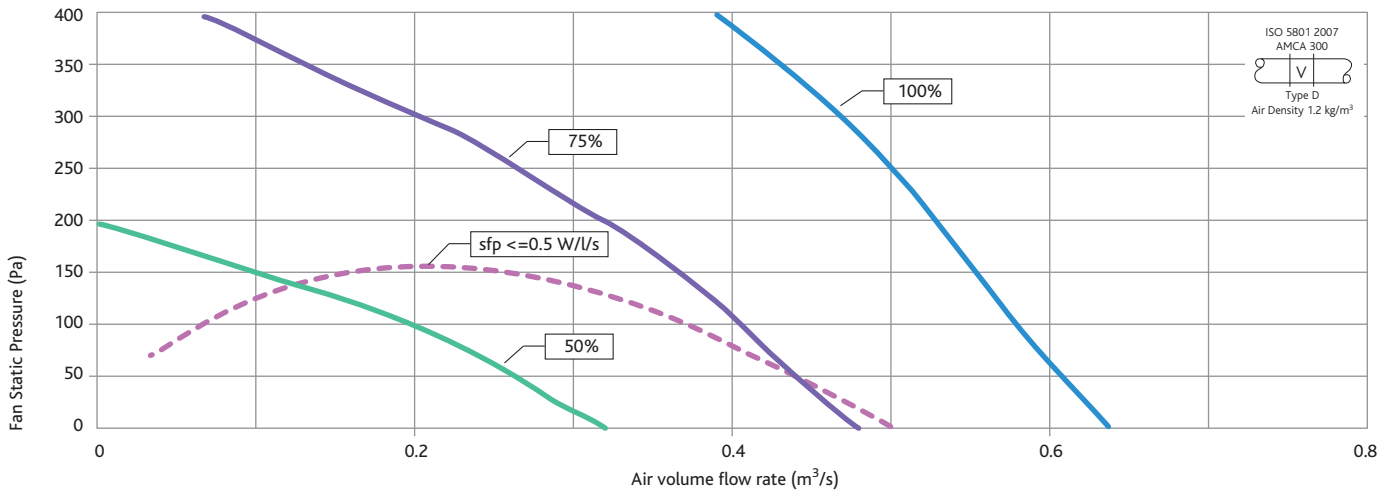

EXTRACT FAN SIZE DE5 - PERFORMANCE

Fan Speed	External Static Pressure (Pa)						
	0	100	200	300	400	500	
100%	Airflow (m ³ /s)	0.64	0.58	0.53	0.47	0.39	0.31
	SFP (W/l/s)	0.805	0.902	1.000	1.134	1.316	1.642
75%	Airflow (m ³ /s)	0.48	0.405	0.32	0.2	0.07	
	SFP (W/l/s)	0.453	0.519	0.656	1.05	3.00	
50%	Airflow (m ³ /s)	0.32	0.195				
	SFP (W/l/s)	0.201	0.329				

For accurate figures, please refer to Nuair Fan Selection Programme at www.nuair.co.uk, alternatively call Nuair on (029 2085 8200).

Unit Code	Voltage/phase Frequency	Input Power (kW)	FLC/SC (A)	Fan Speed (RPM)	Unit Weight (kg)	Packed Weight (kg)	Pallet/Crate Dimensions (mm)
DE5-ES	230 / 1 / 50	0.5	2.2 / 2.2	2250	59	69	800 L x 1400 W x 566 H
DE5A-ES	230 / 1 / 50	0.5	2.2 / 2.2	2250	70	80	1200 L x 1400 W x 566 H

EXTRACT FAN SIZE DE5 - SOUND DATA

Unit Code		Sound Power Levels dB re 1pW								Breakout dBA @ 100% @ 3m	LwA	Breakout dBA @ 75% @ 3m	Breakout dBA @ 50% @ 3m
		63	125	250	500	1K	2K	4K	8K				
DE5-ES	Induct Inlet	89	89	75	72	64	62	61	57	41	76	35	26
	Induct Outlet	92	91	76	73	70	64	59	53		78		
	Breakout	75	70	67	58	53	44	39	34		62		
DE5A-ES	Induct Inlet	84	81	75	63	51	53	53	46	37	70	31	22
	Induct Outlet	86	87	74	71	67	64	59	52		75		
	Breakout	69	64	66	52	46	40	35	28		58		

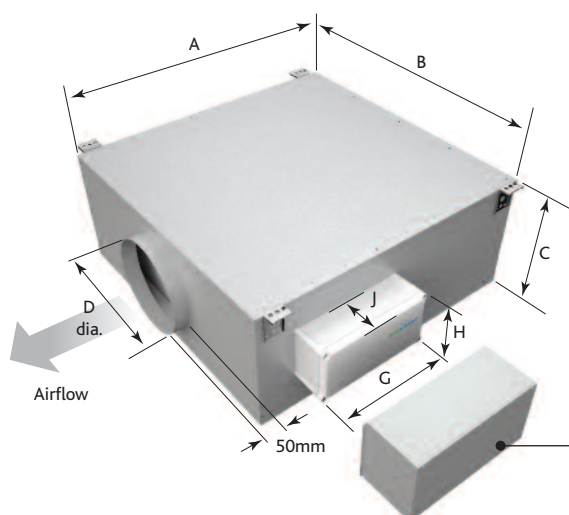

EXTRACT FAN SIZE DE5 - DIMENSIONS (mm)

Unit Code	A	B	C	D (Dia)	Ecosmart control		
					G	H	J
DE5-ES	605	984	410	315	370	150	100
DE5A-ES	1005	984	410	315	370	150	100

Access for Maintenance: Allow 410mm either above or below the unit.
For control box access allow a minimum clearance of 600mm from a wall or barrier.

Removable weatherproof control cover (if required).
Dimensions: 470mm wide x 173mm high x 120mm deep.

DAVE EXTRACT FANS (SIZE DE6 UNIT)

PERFORMANCE & TECHNICAL INFORMATION

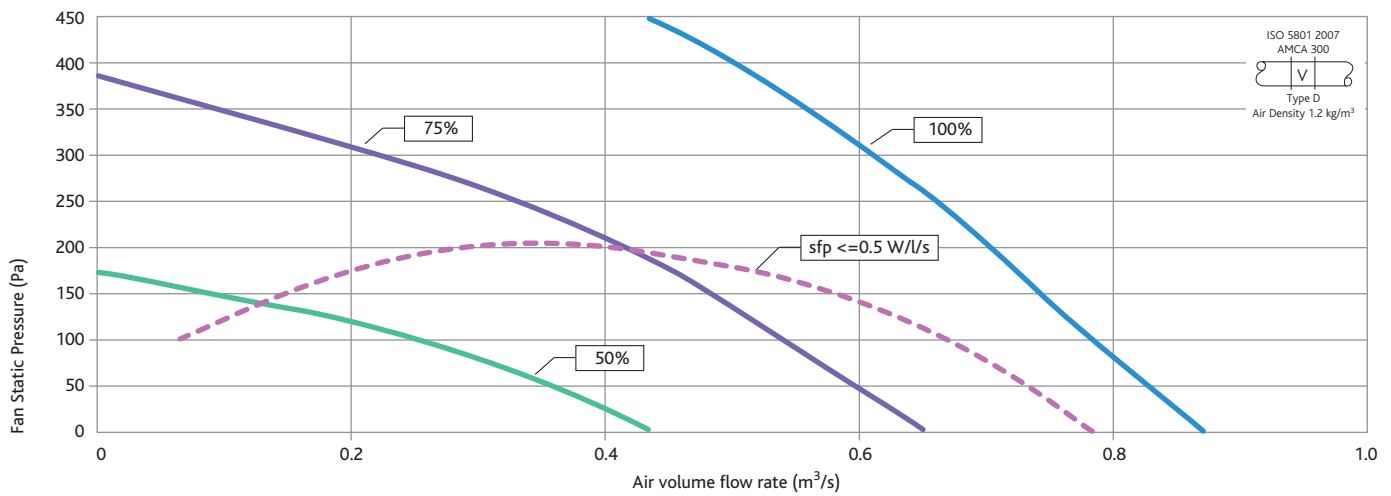

EXTRACT FAN SIZE DE6 - PERFORMANCE

Fan Speed	External Static Pressure (Pa)						
	0	100	200	300	400	500	
100%	Airflow (m ³ /s)	0.87	0.78	0.7	0.61	0.5	0.35
	SFP (W/l/s)	0.561	0.634	0.698	0.820	0.987	1.414
75%	Airflow (m ³ /s)	0.653	0.54	0.41	0.22		
	SFP (W/l/s)	0.316	0.389	0.512	0.96		
50%	Airflow (m ³ /s)	0.435	0.25				
	SFP (W/l/s)	0.140	0.247				

For accurate figures, please refer to Nuair Fan Selection Programme at www.nuair.co.uk, alternatively call Nuair on (029 2085 8200).

Unit Code	Voltage/phase Frequency	Input Power (kW)	FLC/SC (A)	Fan Speed (RPM)	Unit Weight (kg)	Packed Weight (kg)	Pallet/Crate Dimensions (mm)
DE6-ES	230 / 1 / 50	0.45	2.9 / 2.9	1710	69	109	800 L x 1400 W x 611 H
DE6A-ES	230 / 1 / 50	0.45	2.9 / 2.9	1710	75	115	1200 L x 1400 W x 611 H

EXTRACT FAN SIZE DE6 - SOUND DATA

Unit Code		Sound Power Levels dB re 1pW								Breakout dBA @ 100% @ 3m	LwA	Breakout dBA @ 75% @ 3m	Breakout dBA @ 50% @ 3m
		63	125	250	500	1K	2K	4K	8K				
DE6-ES	Induct Inlet	92	88	76	69	68	63	62	55	40	79	34	25
	Induct Outlet	92	88	76	69	68	63	58	51		76		
	Breakout	76	68	67	54	55	44	39	32		78		
DE6A-ES	Induct Inlet	81	88	81	66	55	56	53	49	39	75	33	24
	Induct Outlet	89	89	71	68	66	62	57	50		75		
	Breakout	69	68	67	52	47	40	34	28		78		

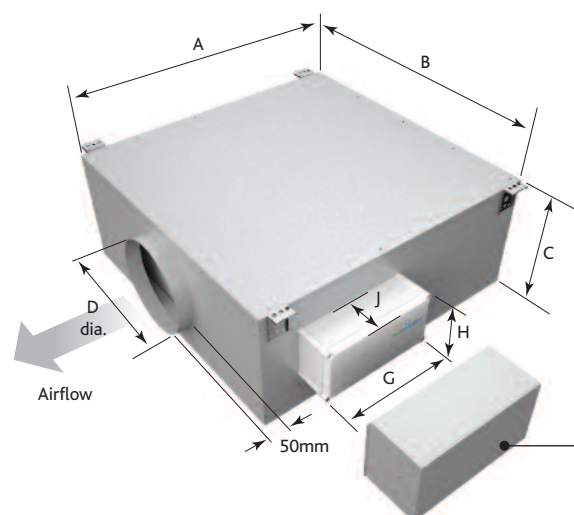

EXTRACT FAN SIZE DE6 - DIMENSIONS (mm)

Unit Code	A	B	C	D (Dia)	Ecosmart control		
	G	H	J				
DE6-ES	605	1092	455	400	370	150	100
DE6A-ES	1005	1092	455	400	370	150	100

Access for Maintenance: Allow 455mm either above or below the unit.
For control box access allow a minimum clearance of 600mm from a wall or barrier.

Removable weatherproof control cover (if required).
Dimensions: 470mm wide x 173mm high x 120mm deep.

DAVE EXTRACT FANS (SIZE DE7 UNIT)

PERFORMANCE & TECHNICAL INFORMATION

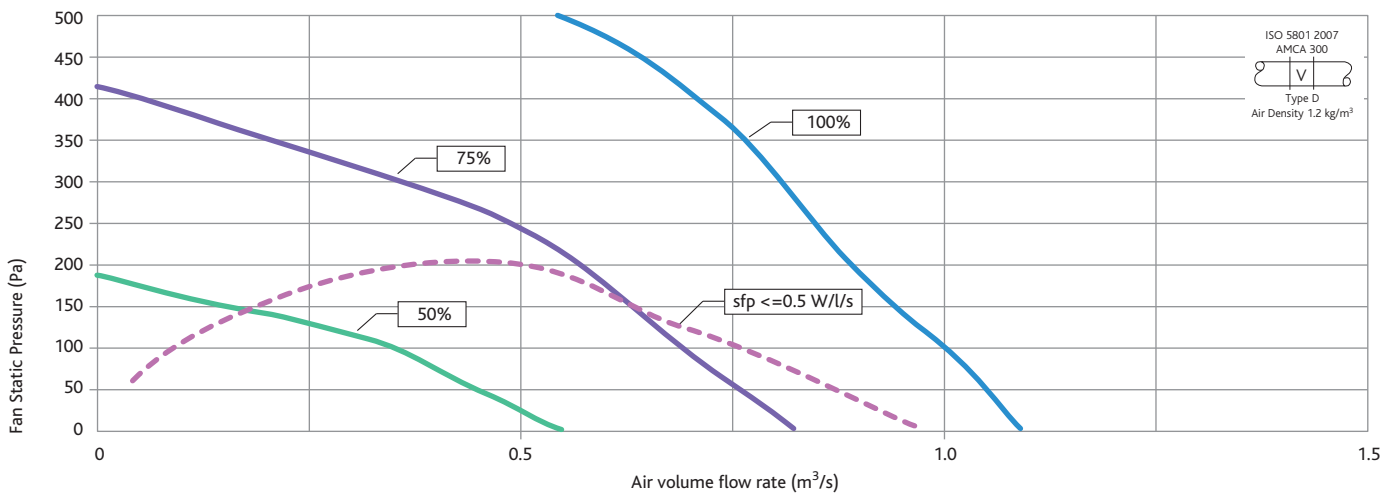

EXTRACT FAN SIZE DE7 - PERFORMANCE

Fan Speed		External Static Pressure (Pa)							
		0	100	200	300	400	500	600	
100%	Airflow (m ³ /s)	1.1	1.0	0.89	0.81	0.71	0.55	0.31	
	SFP (W/l/s)	0.643	0.721	0.816	0.902	1.010	1.268	2.20	
75%	Airflow (m ³ /s)	0.825	0.68	0.57	0.35	0.06			
	SFP (W/l/s)	0.361	0.441	0.526	0.86	5.00			
50%	Airflow (m ³ /s)	0.55	0.355						
	SFP (W/l/s)	0.160	0.252						

For accurate figures, please refer to Nuair Fan Selection Programme at www.nuair.co.uk, alternatively call Nuair on (029 2085 8200).

Unit Code	Voltage/phase Frequency	Input Power (kW)	FLC/SC (A)	Fan Speed (RPM)	Unit Weight (kg)	Packed Weight (kg)	Pallet/Crate Dimensions (mm)
DE7-ES	230 / 1 / 50	0.775	3.5 / 3.5	1650	82	122	800 L x 1400 W x 656 H
DE7A-ES	230 / 1 / 50	0.775	3.5 / 3.5	1650	90	130	1200 L x 1400 W x 656 H

EXTRACT FAN SIZE DE7 - SOUND DATA

Unit Code		Sound Power Levels dB re 1pW								Breakout dBA @ 100% @ 3m	LwA	Breakout dBA @ 75% @ 3m	Breakout dBA @ 50% @ 3m
		63	125	250	500	1K	2K	4K	8K				
DE7-ES	Induct Inlet	87	93	80	72	67	65	62	62	42	79	36	27
	Induct Outlet	96	91	75	71	68	63	59	55		78		
	Breakout	75	72	69	57	55	45	40	37		63		
DE7A-ES	Induct Inlet	84	88	73	66	58	58	54	55	38	74	32	23
	Induct Outlet	91	88	75	69	67	62	58	54		75		
	Breakout	71	68	65	52	49	41	35	34		59		

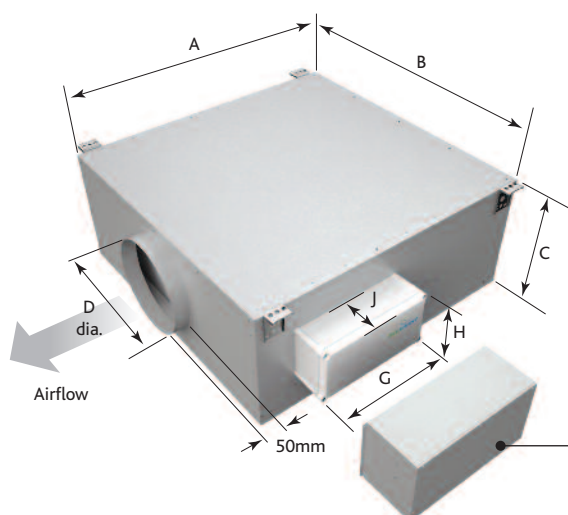

EXTRACT FAN SIZE DE7 - DIMENSIONS (mm)

Unit Code	A	B	C	D (Dia)	Ecosmart control		
					G	H	J
DE7-ES	605	1200	500	400	370	150	100
DE7A-ES	1005	1200	500	400	370	150	100

Access for Maintenance: Allow 500mm either above or below the unit.
For control box access allow a minimum clearance of 600mm from a wall or barrier.

Removable weatherproof control cover (if required).
Dimensions: 470mm wide x 173mm high x 120mm deep.

DAVE SUPPLY FANS

DAVE SUPPLY IS A COMPACT RANGE OF HIGH PERFORMANCE FANS IN 7 CASE SIZES. Including 9 duty curves (2 models providing High Static Pressure).

All models feature the Nuair patented 'Floating fan' design negating the requirement for further AV mounts.

Fans are single skinned construction and manufactured from aluzinc which lasts 5 times longer than galvanised steel and provides higher wear resistance.

All supply fans can be installed internally or externally without the requirement for additional weather protection.

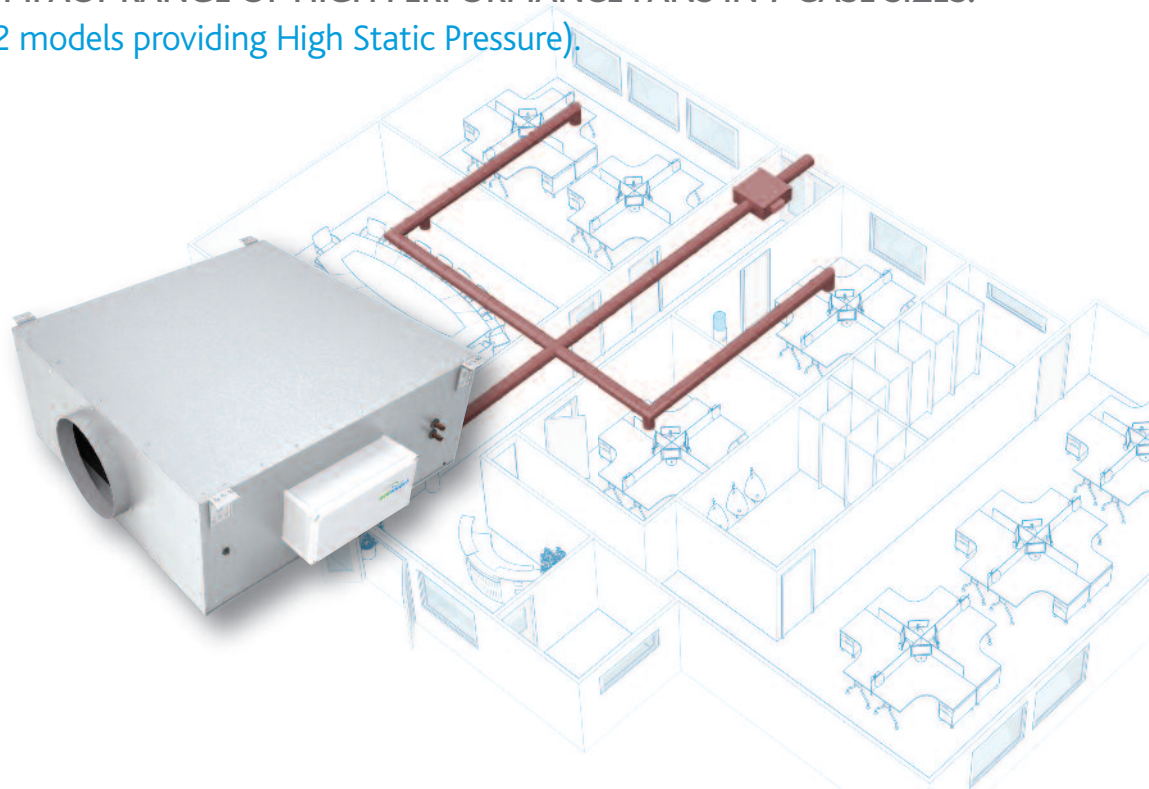

FEATURES AND BENEFITS

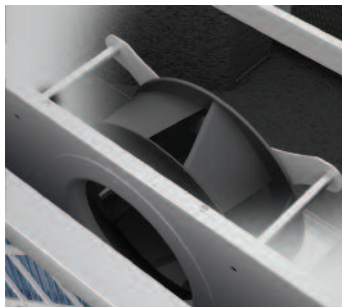

▲ **Patented Floating Fan.** Units are constructed using the Nuair 'Patented' floating fan technology which incorporates an inner casing held inside an outer casing by AV mounts, ensuring any vibration is isolated. This construction removes requirement for additional AV mounts.

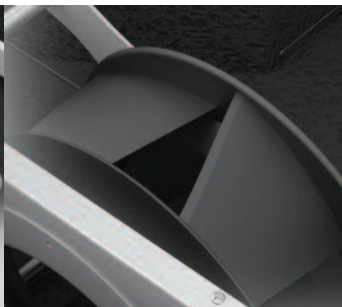

▲ **Latest EC Technology.** Performance optimised backward curved impellers and IP54 EC motors provide low specific fan powers and stepless speed control without tonal noise generation.

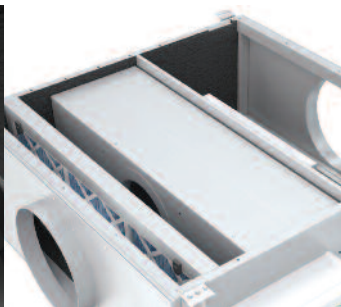

▲ **Multi access.** Compact range ideal for space restricted applications such as ceiling voids. Units have top or bottom access as standard allowing for quick install and easy access to fans for maintenance. Model shown: (DS3A-ES).



▲ **Coils.** LPHW coils are supplied with 2 port Pressure Independent valves (PICV). Electric heaters are supplied with thyristor control. A No heater option is also available.



▲ **Energy efficient 'Plug and Play' control.** Ecosmart energy efficient demand control with pre-programmed soft start function helps prevent electrical overloading and minimises mechanical wear. Weatherproof control cover included (if required).

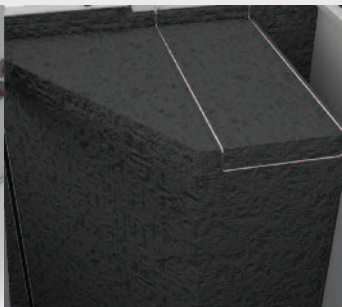

▲ **Attenuation Pods.** All supply fans are single skin and lined with high density acoustic lining. Units* are fitted with attenuated pods to ensure low breakout noise levels.



▲ **Quick installation.** Fans are supplied with a set of support brackets for easy installation or inclusion into an existing drop rod system.

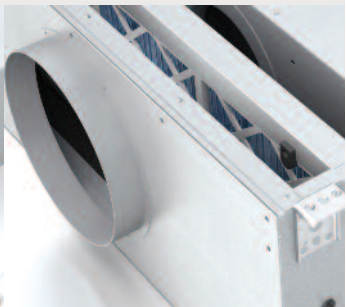

▲ **One solution.** A robust casing design ensures that all units are suitable for internal or external mounting as standard.

DAVE SUPPLY FANS SUMMARY SPECIFICATION

TO HELP YOU SELECT THE APPROPRIATE SOLUTION FOR YOUR SUPPLY APPLICATION, SIMPLY REFER TO THE OPTIONS BELOW.

For details on ancillaries refer to pages 41 - 44.

- Standard
- ▼ Optional
- ✘ Not Available

*Add relevant unit size 1 - 7.

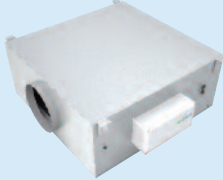
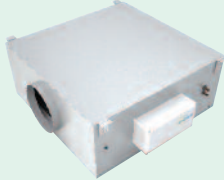
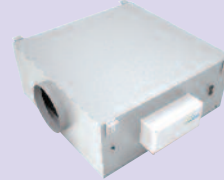
	DAVE SUPPLY PLUS	DAVE SUPPLY PLUS	DAVE SUPPLY PLUS
			
	NO HEATER CODE: DS*A-NES	LPHW COIL CODE: DS*A-LES	ELECTRIC HEATER CODE: DS*A-EES
UNIT SPECIFICATION			
Aluzinc Case	●	●	●
Suitable for internal/external applications	●	●	●
High Performance EC fan	●	●	●
Floating Fan Design	●	●	●
Built-in AV Mounts	●	●	●
Extended Lined Case	●	●	●
No Heater	●	N/A	N/A
Electric Heater & Thyristor Control	✘	✘	●
LPHW Coil	✘	●	✘
2 Port Pressure Independent Valve (PICV)	✘	●	✘
Integrated Attenuation Pods	●	●	●
G4 Filter	●	●	●
F7 Filter	▼	▼	▼
Circular Spigot	●	●	●
Top or Bottom Access	●	●	●
Powder Coated Option (contact Nuair)	▼	▼	▼
FAN ANCILLARIES			
Fast Clamps (Example: FC-150)	▼	▼	▼
Circular Flexible Connector (Example: CFC16)	▼	▼	▼
Silencer internal (SIL-150)	▼	▼	▼
Silencer external (CA25L)	▼	▼	▼
CONTROL SPECIFICATION			
Ecosmart Energy Efficient Plug & Play Control	●	●	●
ECOSMART ANCILLARIES/ENABLERS (ON/OFF)			
ES-PIR2	▼	▼	▼
ES-LCD (Touch screen)	▼	▼	▼
ES-HUMIDISTAT2	▼	▼	▼
ES-THERMOSTAT2	▼	▼	▼
ES-AVI2 (Audio visual indicator)	▼	▼	▼
ES-CO2RM/ES-CO2RMPP (Room mounted)	▼	▼	▼
ES-HTCSIG (Signal conditioning circuit)	▼	▼	▼
ECOSMART ANCILLARIES/CONTROLLING (SENSORS)			
ES-TEMP2	▼	▼	▼
ES-RH2	▼	▼	▼
ES-UCF (Manual control)	▼	▼	▼
ES-CO2 (Duct mounted)	▼	▼	▼
ES-CI (Control interface)	▼	▼	▼
ES-JB (Junction box)	▼	▼	▼
ES-CO2RM/ES-CO2RMPP (Room mounted)	▼	▼	▼

DAVE SUPPLY FANS CONSULTANTS SPECIFICATION

UNIT SPECIFICATION

The Unit shall be configured and arranged as detailed on the drawings and in accordance with the schedule of equipment.

Units have a patented 'Floating Fan' technology incorporating an inner casing which is held inside an outer casing by AV mounts, ensuring any vibration is isolated. This technology eliminates the requirement for additional AV mounts.

The Extended length case Type 'A' shall be acoustically lined and manufactured from heavy gauge, corrosion resistant aluzinc and tested to leakage class 'L2'.

The unit will be manufactured to provide a low height solution to enable it to be located in low depth ceiling and floor voids. The units shall have a maximum depth of 233/300/345/370/410/455/500mm (models DS1-7). For ease of installation the unit shall be supplied complete with 4 mounting brackets for inclusion into a drop rod mounting system.

Impellers shall be of high efficiency, performance and sound optimised backward curved design.

The unit shall be fitted with ErP 2015 rated, low energy, high efficiency IP54 EC motorised fans providing low specific fan powers and stepless speed control without tonal noise generation. Fan/motor assemblies have sealed for life bearings with an anticipated working life of 70,000 hours (L10) and shall be suitable for single phase supply. Units are suitable for operation in ambient temperatures of up to 60°C (unit sizes 1 - 5) and up to 40°C (unit sizes 6 - 7).

The unit and ancillaries shall be of the DAVE Supply type as manufactured by Nuaire Ltd.

COIL TYPES - LOW PRESSURE HOT WATER

(Example code: DS2A-LES)

The Low Pressure Hot Water heating coil shall be factory fitted with a 2-port pressure independent control valve (PICV) and actuator. All components pre-piped, assembled and tested by the manufacturer.

The system shall have frost protection which shall, at temperatures below 4 degrees C, fully open the 2-port pressure independent valve and only start the fan when the temperature in the chamber has risen to the designated set point.

NOTE: Heaters will need an enable signal for heater (ES-LCD, 0-10V BMS or ES-Cl).

ELECTRIC HEATER BATTERY

(Example code: DS2A-EES)

The Electric Heater Battery shall be of stainless steel sheathed element design, factory fitted and pre-wired to an integral closed loop thyristor control.

NOTE: Heaters will need an enable signal for heater (ES-LCD, 0-10V BMS or ES-Cl).

NO HEATER

(Example code: DS2A-NES)

The unit is also available without a heater fitted.

INSTALLATION

By the appointed contractor. The DAVE supply fan can be installed internally or externally as standard without the requirement for additional weather protection. Refer to manufacturers installation and maintenance manual for details on mounting orientation.

Mechanical installation requires mounting of the supply unit in the designated position and connection to the associated duct work. Either Top or bottom access is available. Electrical installation requires the provision and connection of single phase electrical supply at the fan.

INSTALLATION REQUIREMENTS

The mechanical contractor shall ensure that all necessary ancillaries are included eg. flexible connections, additional attenuators, etc.

The contractor shall allow for all necessary ductwork transformations to and from the fan unit and any associated components in accordance with the manufacturer's recommendations, DW 144 and general good practice.

RANGE MODELS

DAVE Supply Plus No Heater: Extended lined case Type 'A', G4 filter, attenuation pods, Energy efficient Ecosmart control. Circular spigots.

DAVE Supply Plus LPHW: Extended lined case Type 'A', LPHW coil with 2 port pressure independent valve (PICV), G4 filter, attenuation pods, Energy efficient Ecosmart control. Circular spigots.

DAVE Supply Plus Electric heater: Electric heater: Extended lined case Type 'A', Electric heater & thyristor control, G4 filter, attenuation pods, Energy efficient Ecosmart control. Circular spigots.

CODE DESCRIPTION

DS7A-LES

||| |||
1234 56

1. DAVE Range
2. Supply fan
3. Case size (1-7)
4. Case type: A = Extended
5. L = LPHW Coil/valve
E = Electric heater,
N = No heater
6. ES = Ecosmart control

CONTROL SPECIFICATION

The fan unit shall be supplied with the following control:-

ECOSMART CONTROL – DEMAND CONTROLLED VENTILATION

Provides the facility for energy saving via an intelligent function with local diagnostics status indication, or allows convenient integration with the client BMS with a minimal co-ordination requirement. The factory fitted Ecosmart control panel mounted to the fan unit includes: integral infinitely variable speed /duty control for the extract fan, with independent minimum, maximum speed adjustment for accurate commissioning. The control assembly is side mounted with a removable weather control fascia (if required).

The Ecosmart control enables the fan's speed to be varied automatically as conditions in the ventilated space change by linking low voltage sensors or as the low voltage user control is adjusted. It also enables multiple fans to be directly interlinked. The user control (ES-LCD) and low voltage sensor are supplied complete with a 10m length of low voltage, pre-plugged cable.

The control features a run on timer and "background" ventilation function, and is provided with unit status indication, run and fail relays and interface connections for Ecosmart sensors and enablers.

DAVE SUPPLY FANS CONSULTANTS SPECIFICATION

The fans shall have the following energy saving and operational functions integrally installed within it, all components will be pre-wired and fitted by the manufacturer:

- Integral frequency inverter/speed controller
- Integral adjustable run-on timer
- Maximum and minimum speed adjustment/ setting (trickle and boost)
- Volt free run & failure/status indication
- 0-10V BMS interface for remote operation, this will enable the following functions:-Switch the unit ON/OFF. Variable speed/duty control, switch from low speed to high speed, enabling heating where applicable.
- Low voltage interface
- Multiple low voltage sockets for interconnection of sensors or fans
- Background ventilation/trickle enable switch.

Fan, Ecosmart controls and associated sensors/ controllers shall be manufactured by Nuair Ltd.

Units fitted with Ecosmart control (code example DS3A-LES) shall have a 5 year warranty.



DAVE Supply Specification Document.

2 PORT PRESSURE INDEPENDENT BALANCING & CONTROL VALVE (PICV)

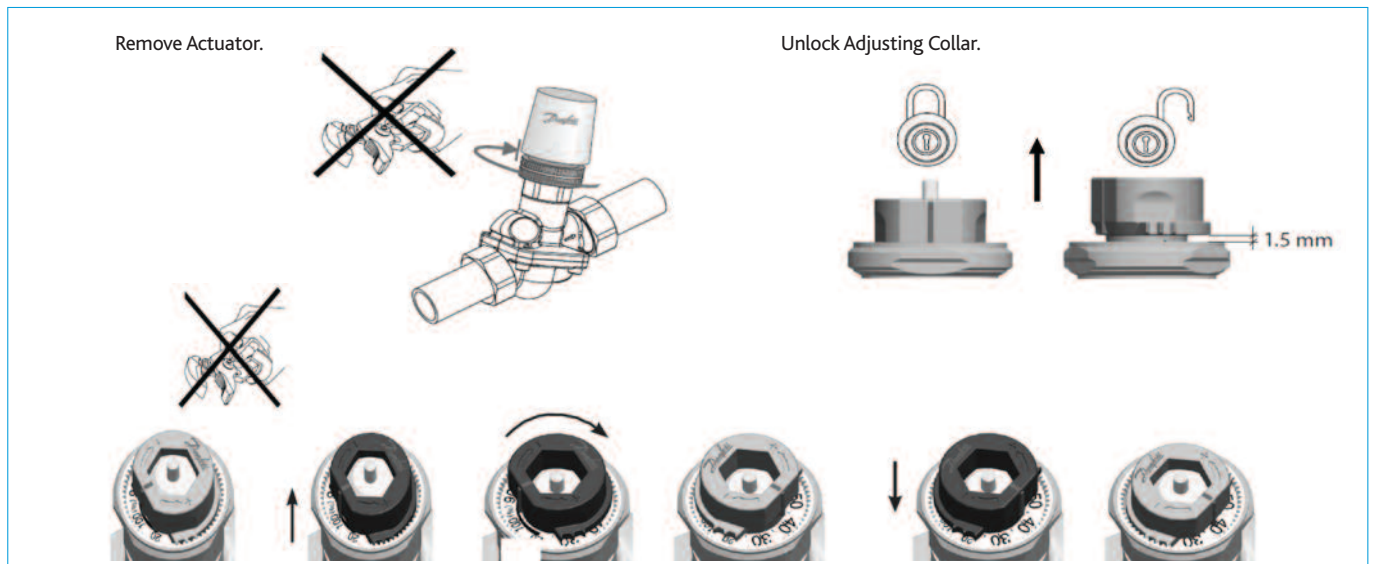

VALVE SETTINGS FOR DAVE SUPPLY UNITS (1 - 7)

UNITS 1, 2 & 2H

DN20	L/h	L/s	GPM
20%	180	0.050	0.80
25%	225	0.063	1.00
30%	270	0.075	1.20
35%	315	0.088	1.40
40%	360	0.100	1.60
45%	405	0.113	1.80
50%	450	0.125	2.00
55%	495	0.138	2.20
60%	540	0.150	2.40
65%	585	0.163	2.60
70%	630	0.175	2.80
75%	675	0.188	3.00
80%	720	0.200	3.20
85%	765	0.213	3.40
90%	810	0.225	3.60
95%	855	0.238	3.80
100%	900	0.250	4.0

UNITS 3, 4 & 4H

DN25	L/h	L/s	GPM
20%	340	0.094	1.50
25%	425	0.118	1.88
30%	510	0.142	2.25
35%	595	0.165	2.63
40%	680	0.189	3.00
45%	765	0.213	3.38
50%	850	0.236	3.75
55%	935	0.260	4.13
60%	1020	0.283	4.50
65%	1105	0.307	4.88
70%	1190	0.331	5.25
75%	1275	0.354	5.63
80%	1360	0.378	6.00
85%	1445	0.401	6.38
90%	1530	0.425	6.75
95%	1615	0.449	7.13
100%	1700	0.472	7.50

UNITS 5, 6 & 7

DN32	L/h	L/s	GPM
20%	640	0.178	2.80
25%	800	0.222	3.50
30%	960	0.267	4.20
35%	1120	0.311	4.90
40%	1280	0.356	5.60
45%	1440	0.400	6.30
50%	1600	0.444	7.00
55%	1760	0.489	7.70
60%	1920	0.533	8.40
65%	2080	0.578	9.10
70%	2240	0.622	9.80
75%	2400	0.667	10.50
80%	2560	0.711	11.20
85%	2720	0.756	11.90
90%	2880	0.800	12.60
95%	3040	0.844	13.30
100%	3200	0.889	14.00

NB: LPHW supply units have a 2 Port Pressure Independent control Valve (PICV) fitted. If the LPHW system is not run via a 'Constant Pressure Pump' then provision must be made to incorporate a 'Bypass' into the system to maintain a minimum level of flow through the pump when the 2 Port PICV is closed.

DAVE SUPPLY FANS WIRING

WIRING CONNECTIONS FOR UNITS WITH ECOSMART CONTROL

a) Mains connections.

Mains cables should be suitably sized and terminated at terminals shown on the appropriate diagram.

b) Control Connections.

Below: 'Net' connection for Ecosmart devices.

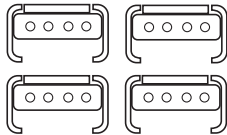

Net - the 4 IDC plug-in connectors are provided for the connection of compatible sensors, manual controls and for linking the fans together under a common control. If more than 4 connections are required, the junction box (product code ES-JB) should be used (see data cable installation).

c) Switched Live (SL) terminal.

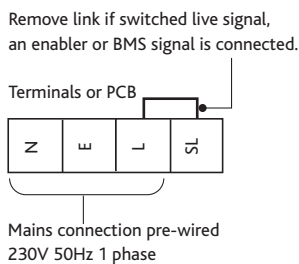

A signal of 100-230V a.c. will activate the fan from either its off state or trickle state (see setting to work-trickle switch).

When the SL is disconnected the fan will over-run (see setting to work-timer adjustment).

Do not take this signal from an isolating transformer.

d) Volt Free Relay Contacts.

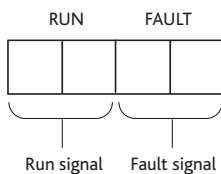

LED INDICATION FOR UNITS WITH ECOSMART CONTROL

PWR	GREEN: Power on & OK. RED: To much power is taken by peripherals or there is a short circuit in the net cable. Check the cable and use a junction box (ES-JB) to connect some of the peripherals.
Standby	LED on when fan is not running.
Fan 1	GREEN: Fan 1 is running, RED: Fan 1 faulty.
Fan 2	GREEN: Fan 2 is running, RED: Fan 2 faulty. (Twin fan only)
Heating*	Not applicable. See note.
Cooling*	Not applicable. See note.
Fault	LED on when a fault is present on unit.
Frost*	Not applicable. See note.
Tx	LED on when the controller is transmitting data.
Rx	LED on when the controller is receiving data.

* Note that the control panel is common to all the Ecosmart products and will have indicators for functions that are not available in this particular fan. However these indicators will not be illuminated.

e) Commissioning panel details.

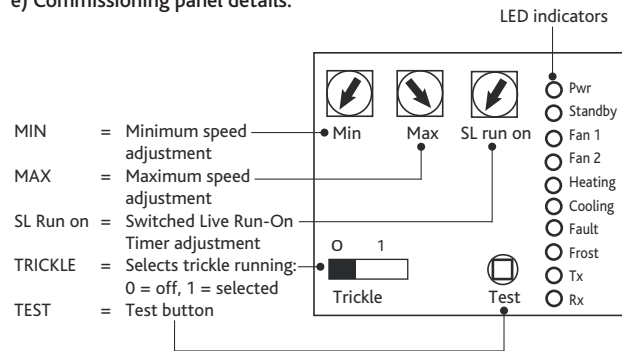

Note: A Commissioning Procedure document is available on request from Nuaire.

THE CONTROL MODULE

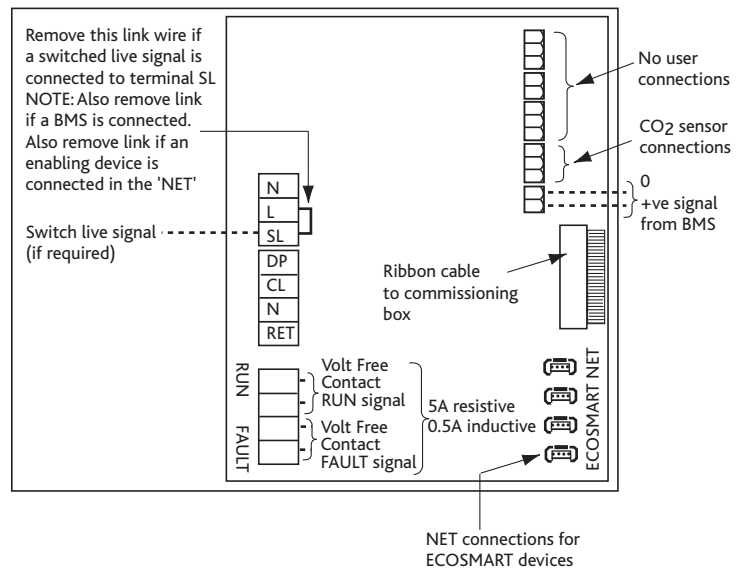

For good EMC engineering practice, any sensor or low voltage data cables should not be placed within 50mm of mains cables or placed on the same cable tray or conduit as mains cables.

DAVE SUPPLY FANS WIRING

WIRING DIAGRAM FOR UNITS WITH LPHW

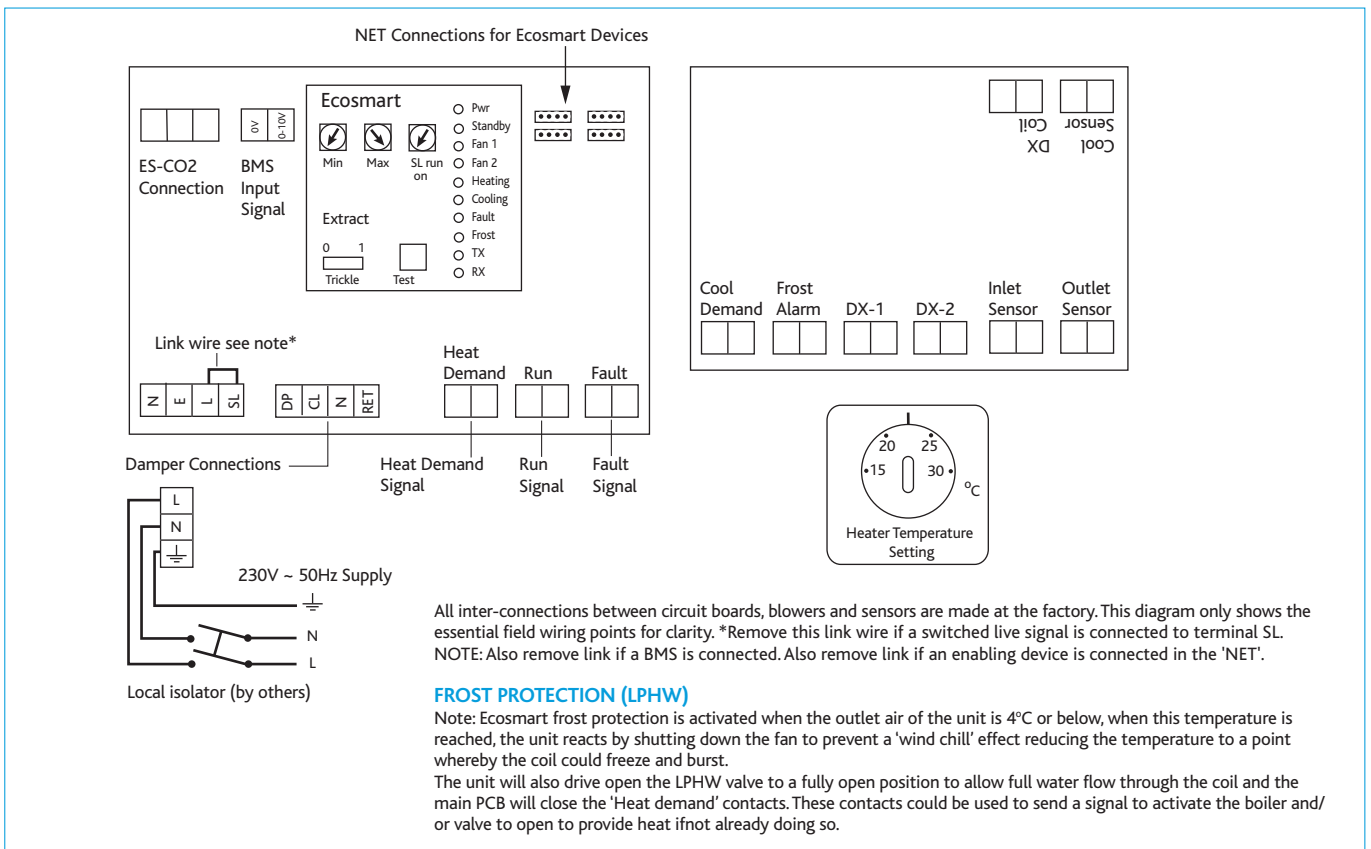

WIRING DIAGRAM FOR UNITS WITH NO HEATER

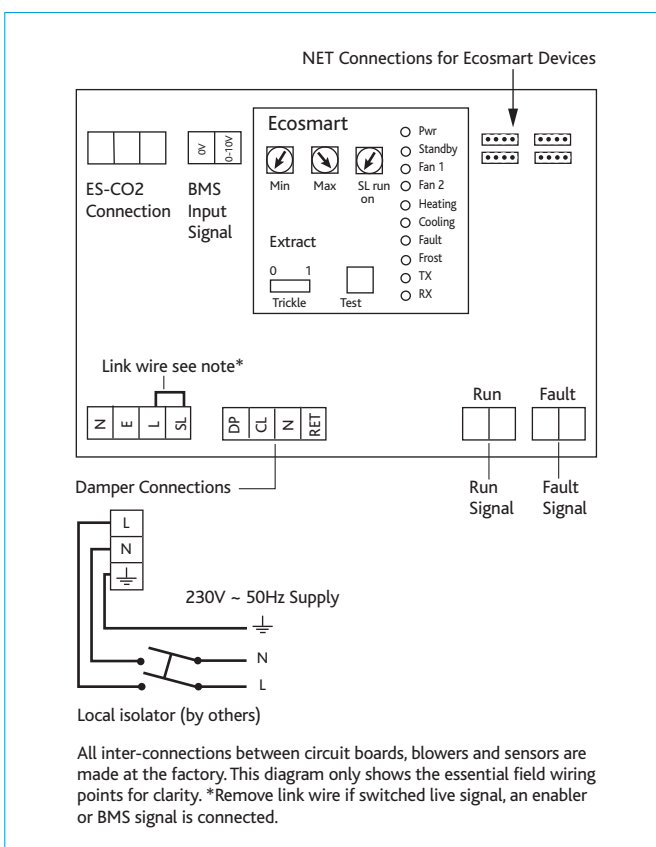

WIRING DIAGRAM FOR UNITS WITH ELECTRIC HEATER UP TO 9kW

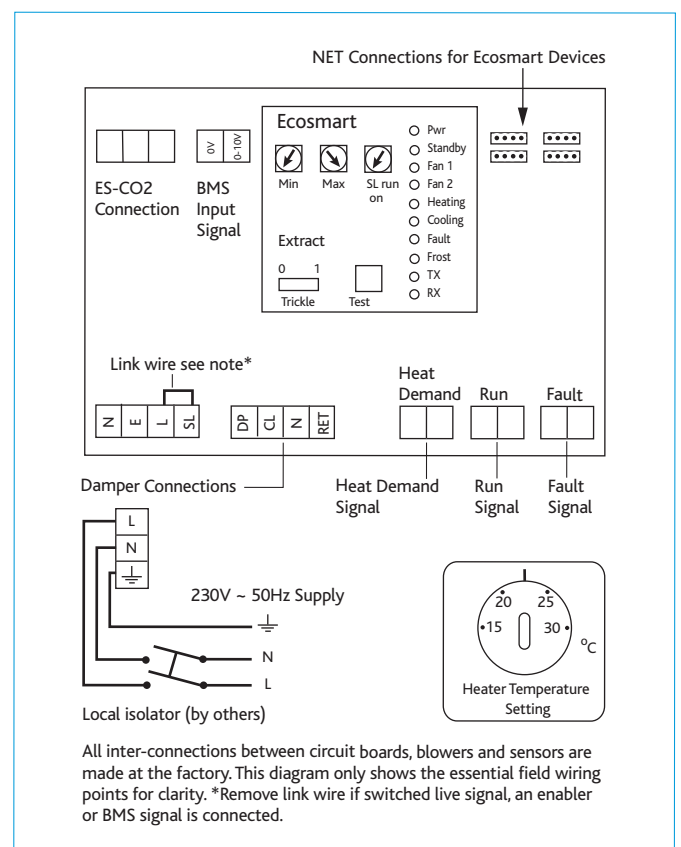

DAVE SUPPLY FANS (SIZE DS1 UNIT)

PERFORMANCE & TECHNICAL INFORMATION

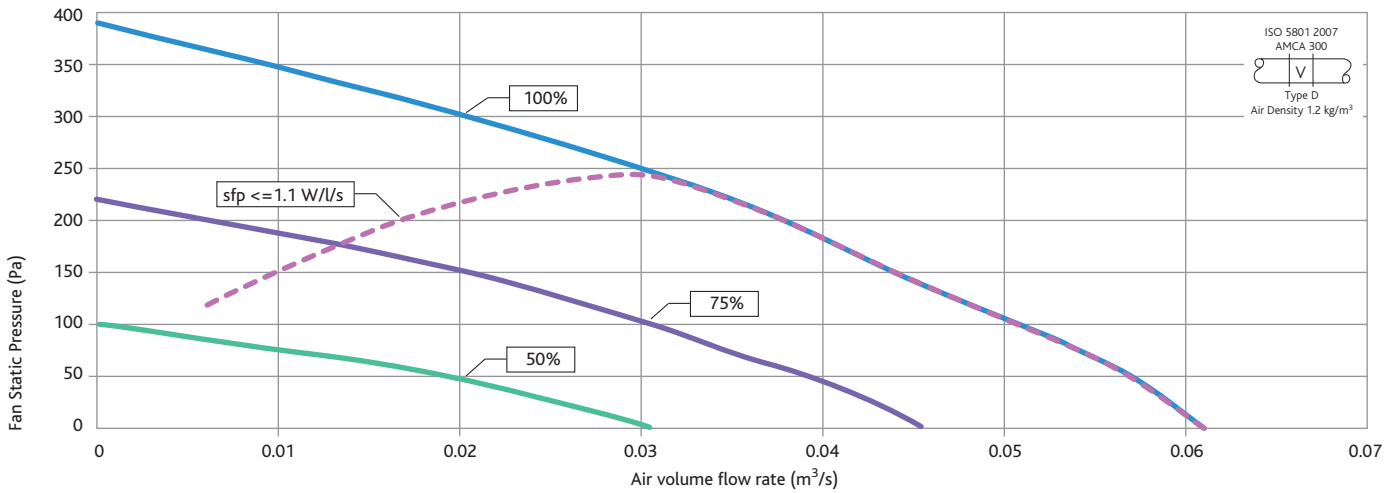

SUPPLY FAN SIZE DS1 - PERFORMANCE

Fan Speed		External Static Pressure (Pa)					
		0	50	100	150	200	250
100%	Airflow (m³/s)	0.061	0.057	0.051	0.044	0.038	0.03
	SFP (W/l/s)	0.520	0.565	0.639	0.752	0.882	1.127
75%	Airflow (m³/s)	0.046	0.039	0.03	0.021	0.006	
	SFP (W/l/s)	0.292	0.360	0.496	0.913	1.890	
50%	Airflow (m³/s)	0.03	0.019				
	SFP (W/l/s)	0.130	0.220				

For accurate figures, please refer to Nuair Fan Selection Programme at www.nuair.co.uk, alternatively call Nuair on (029 2085 8200).

Unit Code	Voltage/phase Frequency	Input Power (kW)	FLC/SC (A)	Fan Speed (RPM)	Unit Weight (kg)	Packed Weight (kg)	Pallet/Crate Dimensions (mm)
DS1A-NES	230 / 1 / 50	0.037	0.27 / 0.27	3770	30	35.5	1200 L x 1000 W x 389 H
DS1A-LES	230 / 1 / 50	0.037	0.27 / 0.27	3770	55	60.5	1200 L x 1000 W x 389 H
DS1A-EES*	230 / 1 / 50	1.037	4.77 / 4.77	3770	50	55.5	1200 L x 1000 W x 389 H

*Includes 1 kW Electric Heater.

SUPPLY FAN SIZE DS1 - SOUND DATA

Unit Code		Sound Power Levels dB re 1pW								Breakout dBA @ 100% @ 3m	LwA	Breakout dBA @ 75% @ 3m	Breakout dBA @ 50% @ 3m
		63	125	250	500	1K	2K	4K	8K				
DS1A-NES	Induct Inlet	60	59	57	51	47	44	47	42	<16	51	<16	<16
	Induct Outlet	59	51	57	50	43	42	43	34		61		
	Breakout	40	44	37	35	23	22	22	6		36		
DS1A-LES	Induct Inlet	60	59	57	51	47	44	47	42	<16	51	<16	<16
	Induct Outlet	59	51	57	50	43	42	43	34		61		
	Breakout	40	44	37	35	23	22	22	6		36		
DS1A-EES	Induct Inlet	60	59	57	51	47	44	47	42	<16	51	<16	<16
	Induct Outlet	59	51	57	50	43	42	43	34		61		
	Breakout	40	44	37	35	23	22	22	6		36		

SUPPLY FAN SIZE DS1 - DATA LPHW 82/71 (Deg C)

Unit size	Airflow (m³/s)	Output (kW)	Air Off Temp (°C)	Water flow (l/s)	Coil ΔP (kPa)*	Pipe Connection (mm)	Valve ΔP (kPa)**
1	0.06	3.55	49.1	0.079	17	15	16

*Liquid ΔP ** Minimum Starting ΔP Data based 0 Degree C Air on temperature.

SUPPLY FAN SIZE DS1 - DIMENSIONS (mm)

Unit Code	Ecosmart control							
	A	B	C	D (Dia)	G	H	J	
DS1A-NES	1005	559	233	150	370	150	100	
DS1A-LES	1005	559	233	150	430	175	190	
DS1A-EES	1005	559	233	150	430	155	155	

Access for Maintenance: Allow 233mm either above or below the unit.

For control box access allow a minimum clearance of 600mm from a wall or barrier.

Removable weatherproof control cover (if required).

NES: 470mm wide x 173mm high x 120mm deep.
LES: 649mm wide x 183mm high x 216mm deep.
EES: 530mm wide x 178mm high x 175mm deep.

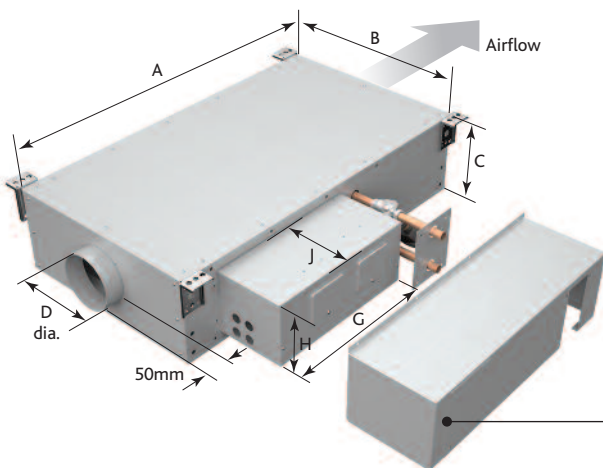

DAVE SUPPLY FANS (SIZE DS2 UNIT)

PERFORMANCE & TECHNICAL INFORMATION

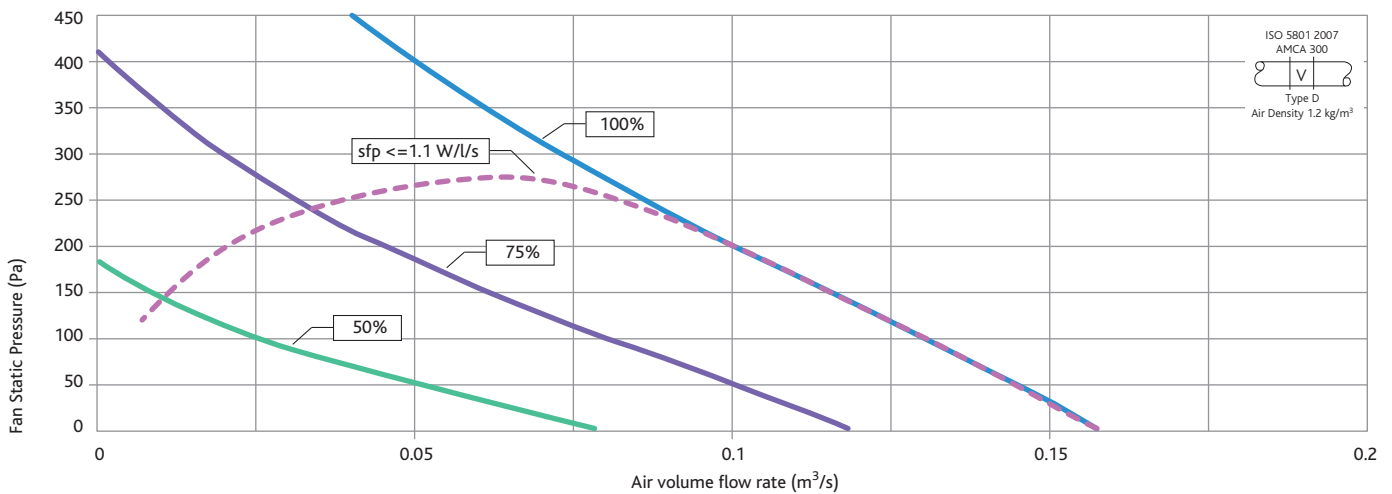

SUPPLY FAN SIZE DS2 - PERFORMANCE

Fan Speed	External Static Pressure (Pa)					
	0	100	200	300	400	
100%	Airflow (m ³ /s)	0.158	0.13	0.1	0.073	0.05
	SFP (W/l/s)	0.503	0.683	0.888	1.214	1.762
75%	Airflow (m ³ /s)	0.119	0.08	0.044	0.02	
	SFP (W/l/s)	0.283	0.499	0.991	1.560	
50%	Airflow (m ³ /s)	0.079	0.025			
	SFP (W/l/s)	0.129	0.440			

For accurate figures, please refer to Nuair Fan Selection Programme at www.nuair.co.uk, alternatively call Nuair on (029 2085 8200).

Unit Code	Voltage/phase Frequency	Input Power (kW)	FLC/SC (A)	Fan Speed (RPM)	Unit Weight (kg)	Packed Weight (kg)	Pallet/Crate Dimensions (mm)
DS2A-NES	230 / 1 / 50	0.088	0.75 / 0.75	3200	40	45.5	1200 L x 1000 W x 456 H
DS2A-LES	230 / 1 / 50	0.088	0.75 / 0.75	3200	60	65.5	1200 L x 1000 W x 456 H
DS2A-EES*	230 / 1 / 50	1.588	7.75 / 7.75	3200	50	55.5	1200 L x 1000 W x 456 H

*Includes 1.5 kW Electric Heater.

SUPPLY FAN SIZE DS2 - SOUND DATA

Unit Code		Sound Power Levels dB re 1pW								Breakout dBA @ 100% @ 3m	LwA	Breakout dBA @ 75% @ 3m	Breakout dBA @ 50% @ 3m
		63	125	250	500	1K	2K	4K	8K				
DS2A-NES	Induct Inlet	68	65	60	57	52	51	52	49	19	60	<16	<16
	Induct Outlet	64	62	56	49	46	49	47	45		56		
	Breakout	50	47	41	37	30	31	29	24		40		
DS2A-LES	Induct Inlet	68	65	60	57	52	51	52	49	19	60	<16	<16
	Induct Outlet	64	62	56	49	46	49	47	45		56		
	Breakout	50	47	41	37	30	31	29	24		40		
DS2A-EES	Induct Inlet	68	65	60	57	52	51	52	49	19	60	<16	<16
	Induct Outlet	64	62	56	49	46	49	47	45		56		
	Breakout	50	47	41	37	30	31	29	24		40		

SUPPLY FAN SIZE DS2 - DATA LPHW 82/71 (Deg C)

Unit size	Airflow (m ³ /s)	Output (kW)	Air Off Temp (°C)	Water flow (l/s)	Coil ΔP (kPa)*	Pipe Connection (mm)	Valve ΔP (kPa)**
2	0.16	4.55	23.6	0.101	5	15	16

*Liquid ΔP ** Minimum Starting ΔP Data based 0 Degree C Air on temperature.

SUPPLY FAN SIZE DS2 - DIMENSIONS (mm)

Unit Code	A	B	C	D (Dia)	Ecosmart control		
					G	H	J
DS2A-NES	1005	696	300	200	370	150	100
DS2A-LES	1005	696	300	200	430	175	190
DS2A-EES	1005	696	300	200	430	155	155

Access for Maintenance: Allow 300mm either above or below the unit.

For control box access allow a minimum clearance of 600mm from a wall or barrier.

Removable weatherproof control cover (if required).

NES: 470mm wide x 173mm high x 120mm deep.
LES: 649mm wide x 183mm high x 216mm deep.
EES: 530mm wide x 178mm high x 175mm deep.

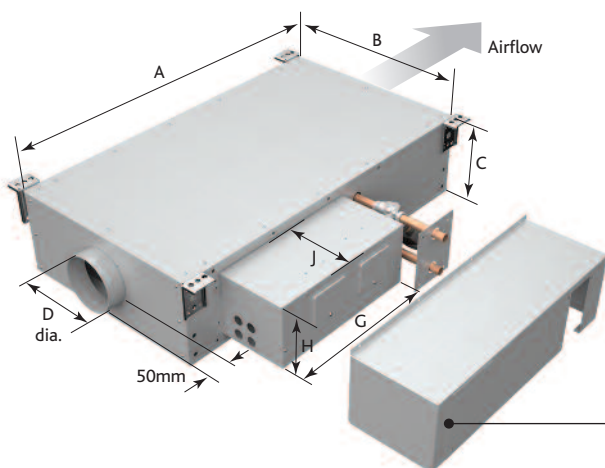

DAVE SUPPLY FANS (SIZE DS2H UNIT)

PERFORMANCE & TECHNICAL INFORMATION

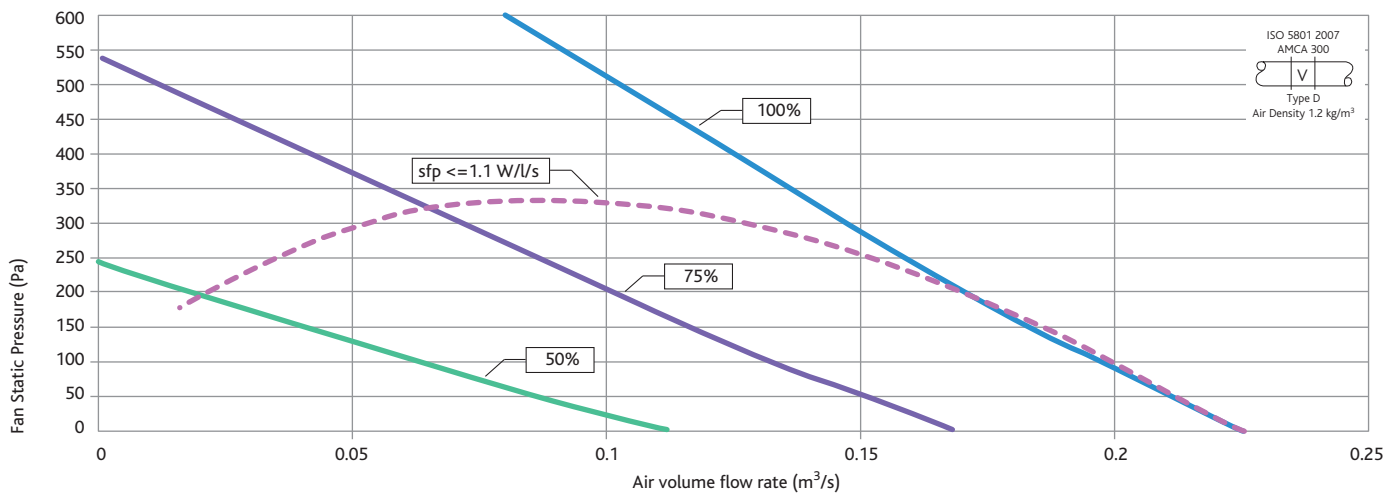

SUPPLY FAN SIZE DS2H - PERFORMANCE

Fan Speed	External Static Pressure (Pa)				
	0	200	400	600	
100%	Airflow (m ³ /s)	0.225	0.17	0.125	0.08
	SFP (W/l/s)	0.760	1.008	1.374	2.143
75%	Airflow (m ³ /s)	0.169	0.1	0.04	
	SFP (W/l/s)	0.427	0.773	2.770	
50%	Airflow (m ³ /s)	0.113	0.02		
	SFP (W/l/s)	0.190	1.230		

For accurate figures, please refer to Nuair Fan Selection Programme at www.nuair.co.uk, alternatively call Nuair on (029 2085 8200).

Unit Code	Voltage/phase Frequency	Input Power (kW)	FLC/SC (A)	Fan Speed (RPM)	Unit Weight (kg)	Packed Weight (kg)	Pallet/Crate Dimensions (mm)
DS2HA-NES	230 / 1 / 50	0.17	1.4 / 1.4	4060	40	45.5	1200 L x 1000 W x 456 H
DS2HA-LES	230 / 1 / 50	0.17	1.4 / 1.4	4060	60	65.5	1200 L x 1000 W x 456 H
DS2HA-EES*	230 / 1 / 50	1.67	8.4 / 8.4	4060	50	55.5	1200 L x 1000 W x 456 H

*Includes 1.5 kW Electric Heater.

SUPPLY FAN SIZE DS2H - SOUND DATA

Unit Code		Sound Power Levels dB re 1pW								Breakout dBA @ 100% @ 3m	LwA	Breakout dBA @ 75% @ 3m	Breakout dBA @ 50% @ 3m
		63	125	250	500	1K	2K	4K	8K				
DS2HA-NES	Induct Inlet	76	73	64	71	59	60	58	59	25	70	19	<16
	Induct Outlet	73	68	61	57	55	56	54	54		63		
	Breakout	53	56	40	45	36	35	32	26		46		
DS2HA-LES	Induct Inlet	76	73	64	71	59	60	58	59	25	70	19	<16
	Induct Outlet	73	68	61	57	55	56	54	54		63		
	Breakout	53	56	40	45	36	35	32	26		46		
DS2HA-EES	Induct Inlet	76	73	64	71	59	60	58	59	25	70	19	<16
	Induct Outlet	73	68	61	57	55	56	54	54		63		
	Breakout	53	56	40	45	36	35	32	26		46		

SUPPLY FAN SIZE DS2H - DATA LPHW 82/71 (Deg C)

Unit size	Airflow (m ³ /s)	Output (kW)	Air Off Temp (°C)	Water flow (l/s)	Coil ΔP (kPa)*	Pipe Connection (mm)	Valve ΔP (kPa)**
2H	0.21	5.65	22.37	0.126	7	15	16

*Liquid ΔP ** Minimum Starting ΔP Data based 0 Degree C Air on temperature.

SUPPLY FAN SIZE DS2H - DIMENSIONS (mm)

Unit Code	Ecosmart control						
	A	B	C	D (Dia)	G	H	J
DS2HA-NES	1005	696	300	200	370	150	100
DS2HA-LES	1005	696	300	200	430	175	190
DS2HA-EES	1005	696	300	200	430	155	155

Access for Maintenance: Allow 300mm either above or below the unit.

For control box access allow a minimum clearance of 600mm from a wall or barrier.

Removable weatherproof control cover (if required).

NES: 470mm wide x 173mm high x 120mm deep.
LES: 649mm wide x 183mm high x 216mm deep.
EES: 530mm wide x 178mm high x 175mm deep.

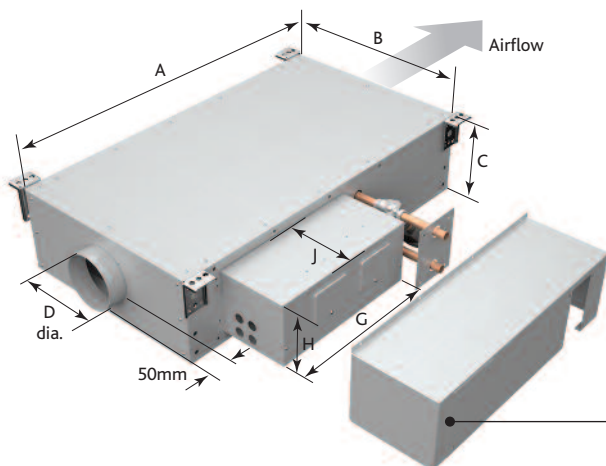

DAVE SUPPLY FANS (SIZE DS3 UNIT)

PERFORMANCE & TECHNICAL INFORMATION

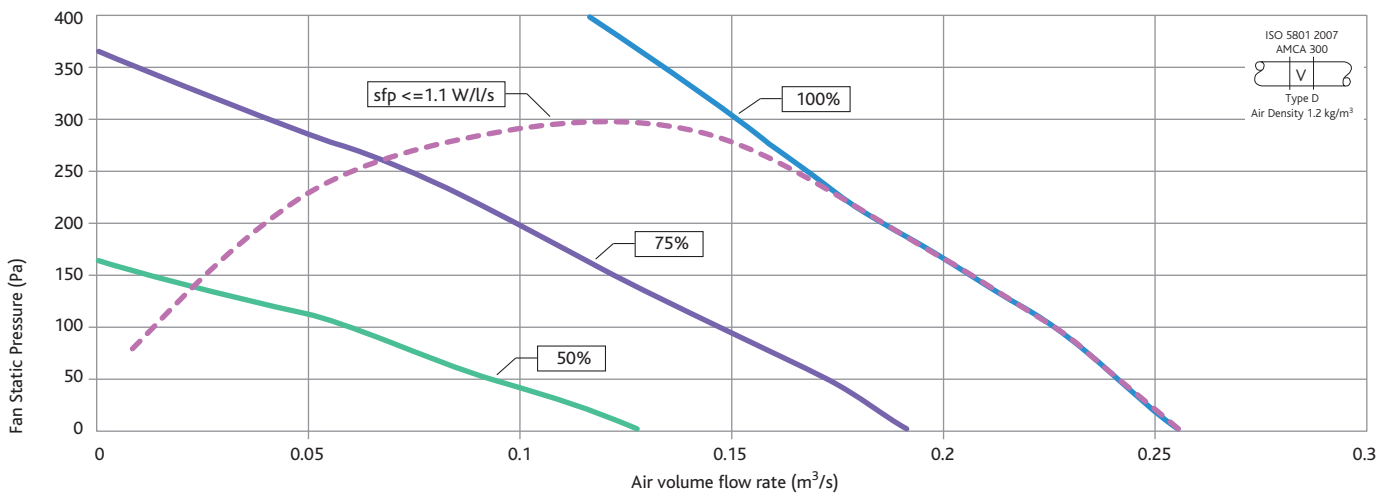

SUPPLY FAN SIZE DS3 - PERFORMANCE

Fan Speed	External Static Pressure (Pa)						
	0	100	200	300	400	500	
100%	Airflow (m ³ /s)	0.255	0.225	0.185	0.15	0.115	0.07
	SFP (W/l/s)	0.611	0.773	0.942	1.165	1.518	2.489
75%	Airflow (m ³ /s)	0.191	0.145	0.1	0.04		
	SFP (W/l/s)	0.344	0.530	0.854	4.900		
50%	Airflow (m ³ /s)	0.128	0.058				
	SFP (W/l/s)	0.153	0.380				

For accurate figures, please refer to Nuair Fan Selection Programme at www.nuair.co.uk, alternatively call Nuair on (029 2085 8200).

Unit Code	Voltage/phase Frequency	Input Power (kW)	FLC/SC (A)	Fan Speed (RPM)	Unit Weight (kg)	Packed Weight (kg)	Pallet/Crate Dimensions (mm)
DS3A-NES	230 / 1 / 50	0.17	1.4 / 1.4	2860	45	55	1200 L x 1000 W x 501 H
DS3A-LES	230 / 1 / 50	0.17	1.4 / 1.4	2860	65	75	1200 L x 1000 W x 501 H
DS3A-EES*	230 / 1 / 50	2.17	10.4 / 10.4	2860	55	65	1200 L x 1000 W x 501 H

*Includes 2 kW Electric Heater.

SUPPLY FAN SIZE DS3 - SOUND DATA

Unit Code		Sound Power Levels dB re 1pW								Breakout dBA @ 100% @ 3m	LwA	Breakout dBA @ 75% @ 3m	Breakout dBA @ 50% @ 3m
		63	125	250	500	1K	2K	4K	8K				
DS3A-NES	Induct Inlet	82	75	63	65	58	55	58	55	29	67	23	<16
	Induct Outlet	85	77	61	50	50	54	53	52		65		
	Breakout	62	64	53	43	37	33	27	21		50		
DS3A-LES	Induct Inlet	82	75	63	65	58	55	58	55	29	67	23	<16
	Induct Outlet	85	77	61	50	50	54	53	52		65		
	Breakout	62	64	53	43	37	33	27	21		50		
DS3A-EES	Induct Inlet	82	75	63	65	58	55	58	55	29	67	23	<16
	Induct Outlet	85	77	61	50	50	54	53	52		65		
	Breakout	62	64	53	43	37	33	27	21		50		

SUPPLY FAN SIZE DS3 - DATA LPHW 82/71 (Deg C)

Unit size	Airflow (m ³ /s)	Output (kW)	Air Off Temp (°C)	Water flow (l/s)	Coil ΔP (kPa)*	Pipe Connection (mm)	Valve ΔP (kPa)**
3	0.28	11.83	35.2	0.264	12	22	20

*Liquid ΔP ** Minimum Starting ΔP Data based 0 Degree C Air on temperature.

SUPPLY FAN SIZE DS3 - DIMENSIONS (mm)

Unit Code	Ecosmart control						
	A	B	C	D (Dia)	G	H	J
DS3A-NES	1005	780	345	200	370	150	100
DS3A-LES	1005	780	345	200	430	175	190
DS3A-EES	1005	780	345	200	430	155	155

Access for Maintenance: Allow 345mm either above or below the unit.

For control box access allow a minimum clearance of 600mm from a wall or barrier.

Removable weatherproof control cover (if required).

NES: 470mm wide x 173mm high x 120mm deep.
LES: 649mm wide x 243mm high x 256mm deep.
EES: 530mm wide x 178mm high x 175mm deep.

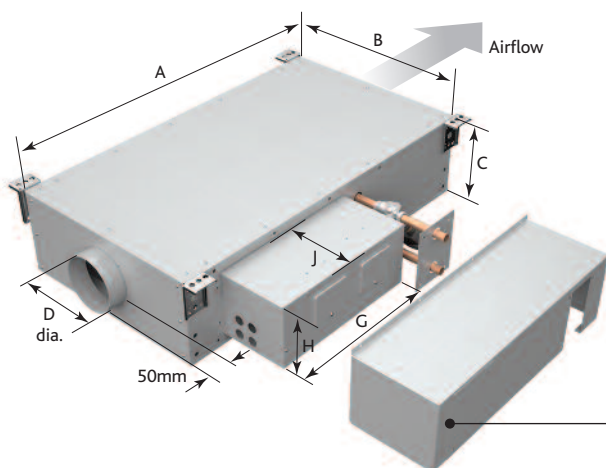

DAVE SUPPLY FANS (SIZE DS4 UNIT)

PERFORMANCE & TECHNICAL INFORMATION

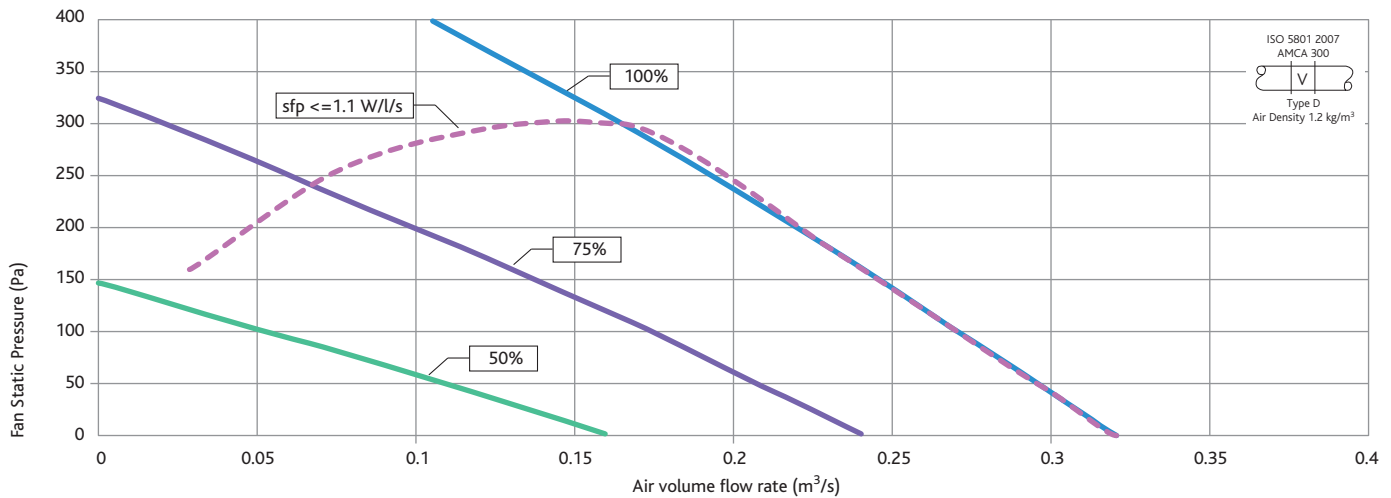

SUPPLY FAN SIZE DS4 - PERFORMANCE

Fan Speed	External Static Pressure (Pa)					
	0	100	200	300	400	
100%	Airflow (m³/s)	0.32	0.27	0.22	0.165	0.105
	SFP (W/l/s)	0.480	0.638	0.779	1.043	1.637
75%	Airflow (m³/s)	0.24	0.175	0.1	0.02	
	SFP (W/l/s)	0.270	0.417	0.730	3.650	
50%	Airflow (m³/s)	0.16	0.053			
	SFP (W/l/s)	0.120	0.409			

For accurate figures, please refer to Nuair Fan Selection Programme at www.nuair.co.uk, alternatively call Nuair on (029 2085 8200).

Unit Code	Voltage/phase Frequency	Input Power (kW)	FLC/SC (A)	Fan Speed (RPM)	Unit Weight (kg)	Packed Weight (kg)	Pallet/Crate Dimensions (mm)
DS4A-NES	230 / 1 / 50	0.17	1.35 / 1.35	2550	50	60	1200 L x 1200 W x 526 H
DS4A-LES	230 / 1 / 50	0.17	1.35 / 1.35	2550	70	80	1200 L x 1200 W x 526 H
DS4A-EES*	230 / 1 / 50	3.17	14.34 / 14.34	2550	60	70	1200 L x 1200 W x 526 H

*Includes 3 kW Electric Heater.

SUPPLY FAN SIZE DS4 - SOUND DATA

Unit Code		Sound Power Levels dB re 1pW								Breakout dBA @ 100% @ 3m	LwA	Breakout dBA @ 75% @ 3m	Breakout dBA @ 50% @ 3m
		63	125	250	500	1K	2K	4K	8K				
DS4A-NES	Induct Inlet	77	72	64	64	56	55	54	51	22	65	16	<16
	Induct Outlet	79	76	60	53	52	55	49	49		63		
	Breakout	58	53	46	40	34	32	25	19		43		
DS4A-LES	Induct Inlet	77	72	64	64	56	55	54	51	22	65	16	<16
	Induct Outlet	79	76	60	53	52	55	49	49		63		
	Breakout	58	53	46	40	34	32	25	19		43		
DS4A-EES	Induct Inlet	77	72	64	64	56	55	54	51	22	65	16	<16
	Induct Outlet	79	76	60	53	52	55	49	49		63		
	Breakout	58	53	46	40	34	32	25	19		43		

SUPPLY FAN SIZE DS4 - DATA LPHW 82/71 (Deg C)

Unit size	Airflow (m³/s)	Output (kW)	Air Off Temp (°C)	Water flow (l/s)	Coil ΔP (kPa)*	Pipe Connection (mm)	Valve ΔP (kPa)**
4	0.39	15.8	33.7	0.352	5	22	20

*Liquid ΔP ** Minimum Starting ΔP Data based 0 Degree C Air on temperature.

SUPPLY FAN SIZE DS4 - DIMENSIONS (mm)

Unit Code	Ecosmart control						
	A	B	C	D (Dia)	G	H	J
DS4A-NES	1005	840	370	250	370	150	100
DS4A-LES	1005	840	370	250	430	175	190
DS4A-EES	1005	840	370	250	430	155	155

Access for Maintenance: Allow 370mm either above or below the unit.

For control box access allow a minimum clearance of 600mm from a wall or barrier.

Removable weatherproof control cover (if required).

NES: 470mm wide x 173mm high x 120mm deep.
LES: 649mm wide x 251mm high x 256mm deep.
EES: 530mm wide x 178mm high x 175mm deep.

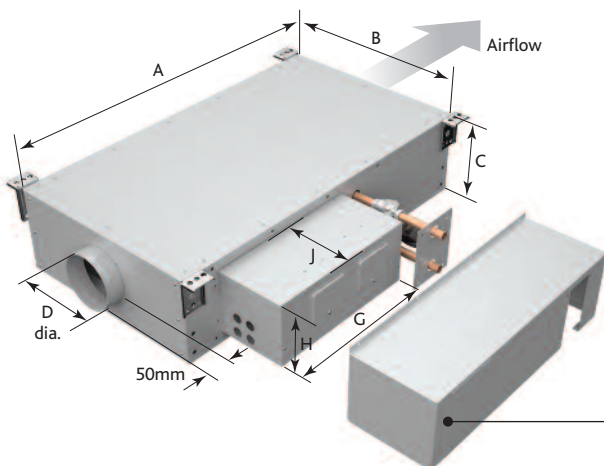

DAVE SUPPLY FANS (SIZE DS4H UNIT)

PERFORMANCE & TECHNICAL INFORMATION

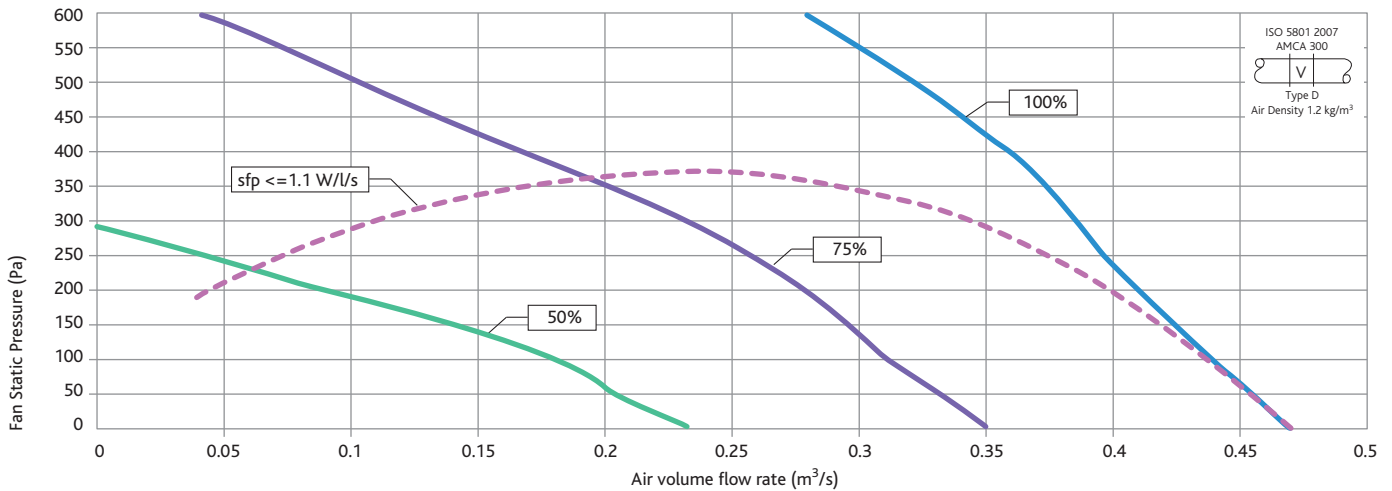

SUPPLY FAN SIZE DS4H - PERFORMANCE

Fan Speed	External Static Pressure (Pa)					
	0	200	400	600	800	
100%	Airflow (m ³ /s)	0.47	0.41	0.36	0.28	0.18
	SFP (W/l/s)	0.952	1.140	1.355	1.772	2.905
75%	Airflow (m ³ /s)	0.353	0.28	0.17	0.04	
	SFP (W/l/s)	0.536	0.762	1.29	5.50	
50%	Airflow (m ³ /s)	0.235	0.09			
	SFP (W/l/s)	0.238	0.726			

For accurate figures, please refer to Nuair Fan Selection Programme at www.nuair.co.uk, alternatively call Nuair on (029 2085 8200).

Unit Code	Voltage/phase Frequency	Input Power (kW)	FLC/SC (A)	Fan Speed (RPM)	Unit Weight (kg)	Packed Weight (kg)	Pallet/Crate Dimensions (mm)
DS4HA-NES	230 / 1 / 50	0.49	2.2 / 2.2	3700	70	80	1200 L x 1200 W x 526 H
DS4HA-LES	230 / 1 / 50	0.49	2.2 / 2.2	3700	70	80	1200 L x 1200 W x 526 H
DS4HA-EES	230 / 1 / 50	3.49	15.2 / 15.2	3700	60	70	1200 L x 1200 W x 526 H

*Includes 3 kW Electric Heater.

SUPPLY FAN SIZE DS4H - SOUND DATA

Unit Code		Sound Power Levels dB re 1pW								Breakout dBA @ 100% @ 3m	LwA	Breakout dBA @ 75% @ 3m	Breakout dBA @ 50% @ 3m
		63	125	250	500	1K	2K	4K	8K				
DS4HA-NES	Induct Inlet	83	78	70	74	69	68	64	66	32	76	26	17
	Induct Outlet	89	83	68	65	65	67	61	60		73		
	Breakout	66	60	53	51	47	44	37	32		53		
DS4HA-LES	Induct Inlet	83	78	70	74	69	68	64	66	32	76	26	17
	Induct Outlet	89	83	68	65	65	67	61	60		73		
	Breakout	66	60	53	51	47	44	37	32		53		
DS4HA-EES	Induct Inlet	83	78	70	74	69	68	64	66	32	76	26	17
	Induct Outlet	89	83	68	65	65	67	61	60		73		
	Breakout	66	60	53	51	47	44	37	32		53		

SUPPLY FAN SIZE DS4H - DATA LPHW 82/71 (Deg C)

Unit size	Airflow (m ³ /s)	Output (kW)	Air Off Temp (°C)	Water flow (l/s)	Coil ΔP (kPa)*	Pipe Connection (mm)	Valve ΔP (kPa)**
4H	0.42	16.69	33	0.371	6	22	20

*Liquid ΔP ** Minimum Starting ΔP Data based 0 Degree C Air on temperature.

SUPPLY FAN SIZE DS4H - DIMENSIONS (mm)

Unit Code	Ecosmart control						
	A	B	C	D (Dia)	G	H	J
DS4HA-NES	1005	840	370	250	370	150	100
DS4HA-LES	1005	840	370	250	430	175	190
DS4HA-EES	1005	840	370	250	430	155	155

Access for Maintenance: Allow 370mm either above or below the unit.

For control box access allow a minimum clearance of 600mm from a wall or barrier.

Removable weatherproof control cover (if required).

NES: 470mm wide x 173mm high x 120mm deep.
LES: 649mm wide x 251mm high x 256mm deep.
EES: 530mm wide x 178mm high x 175mm deep.

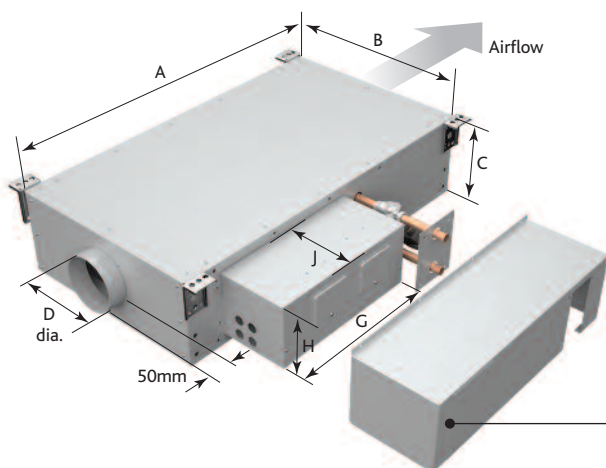

DAVE SUPPLY FANS (SIZE DS5 UNIT)

PERFORMANCE & TECHNICAL INFORMATION

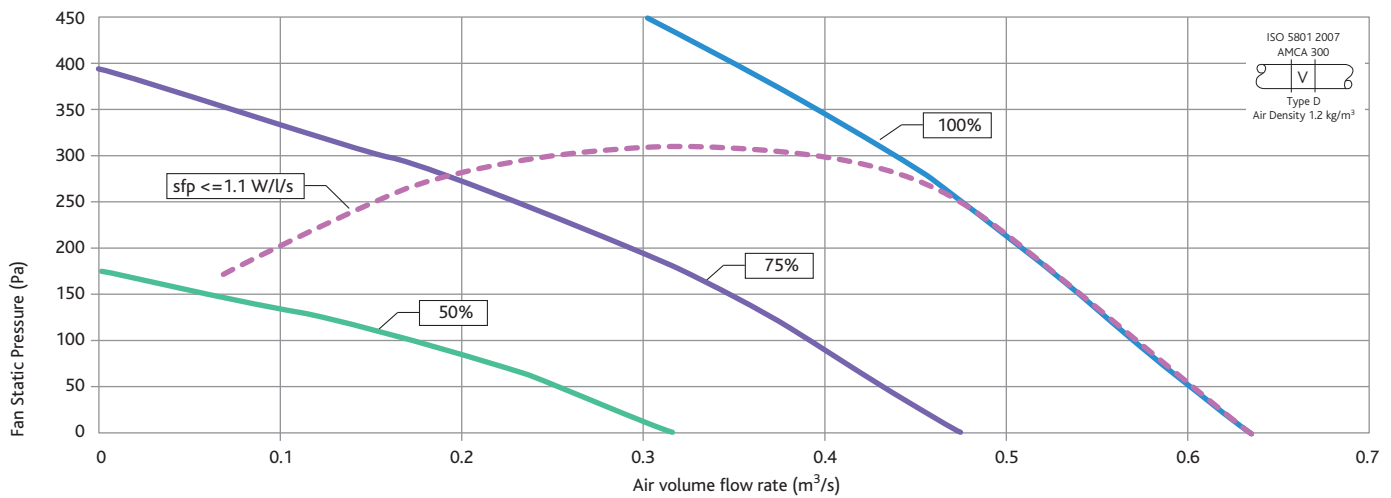

SUPPLY FAN SIZE DS5 - PERFORMANCE

Fan Speed		External Static Pressure (Pa)					
		0	100	200	300	400	500
100%	Airflow (m³/s)	0.635	0.57	0.51	0.44	0.35	0.25
	SFP (W/l/s)	0.783	0.879	0.999	1.151	1.426	2.002
75%	Airflow (m³/s)	0.476	0.39	0.295	0.16		
	SFP (W/l/s)	0.440	0.583	0.712	1.313		
50%	Airflow (m³/s)	0.318	0.175				
	SFP (W/l/s)	0.196	0.356				

For accurate figures, please refer to Nuair Fan Selection Programme at www.nuair.co.uk, alternatively call Nuair on (029 2085 8200).

Unit Code	Voltage/phase Frequency	Input Power (kW)	FLC/SC (A)	Fan Speed (RPM)	Unit Weight (kg)	Packed Weight (kg)	Pallet/Crate Dimensions (mm)
DS5A-NES	230 / 1 / 50	0.5	2.2 / 2.2	2250	75	85	1200 L x 1400 W x 566 H
DS5A-LES	230 / 1 / 50	0.5	2.2 / 2.2	2250	105	115	1200 L x 1400 W x 566 H
DS5A-EES*	230 / 1 / 50	5	22.2 / 22.2	2250	90	100	1200 L x 1400 W x 566 H

*Includes 4.5 kW Electric Heater.

SUPPLY FAN SIZE DS5 - SOUND DATA

Unit Code		Sound Power Levels dB re 1pW								Breakout dBA @ 100% @ 3m	LwA	Breakout dBA @ 75% @ 3m	Breakout dBA @ 50% @ 3m
		63	125	250	500	1K	2K	4K	8K				
DS5A-NES	Induct Inlet	85	85	78	70	61	60	59	53	38	74	32	23
	Induct Outlet	84	79	73	65	58	56	53	45		69		
	Breakout	68	62	67	53	46	39	35	28		59		
DS5A-LES	Induct Inlet	86	87	79	70	61	60	58	52	37	75	31	22
	Induct Outlet	82	79	68	69	58	56	52	44		69		
	Breakout	68	64	65	55	46	39	34	27		58		
DS5A-EES	Induct Inlet	85	85	78	70	61	60	59	53	38	74	32	23
	Induct Outlet	84	79	73	65	58	56	53	45		69		
	Breakout	68	62	67	53	46	39	35	28		59		

SUPPLY FAN SIZE DS5 - DATA LPHW 82/71 (Deg C)

Unit size	Airflow (m³/s)	Output (kW)	Air Off Temp (°C)	Water flow (l/s)	Coil ΔP (kPa)*	Pipe Connection (mm)	Valve ΔP (kPa)**
5	0.7	29.1	34.6	0.65	12	22	20

*Liquid ΔP ** Minimum Starting ΔP Data based 0 Degree C Air on temperature.

SUPPLY FAN SIZE DS5 - DIMENSIONS (mm)

Unit Code	Ecosmart control							
	A	B	C	D (Dia)	G	H	J	
DS5A-NES	1155	984	410	315	370	150	100	
DS5A-LES	1155	984	410	315	430	175	190	
DS5A-EES	1155	984	410	315	430	155	155	

Access for Maintenance: Allow 410mm either above or below the unit.

For control box access allow a minimum clearance of 600mm from a wall or barrier.

Removable weatherproof control cover (if required).

NES: 470mm wide x 173mm high x 120mm deep.
LES: 649mm wide x 323mm high x 281mm deep.
EES: 530mm wide x 178mm high x 175mm deep.

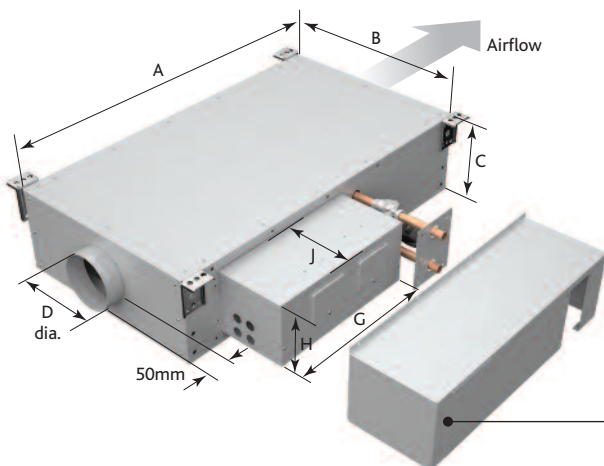

DAVE SUPPLY FANS (SIZE DS6 UNIT)

PERFORMANCE & TECHNICAL INFORMATION

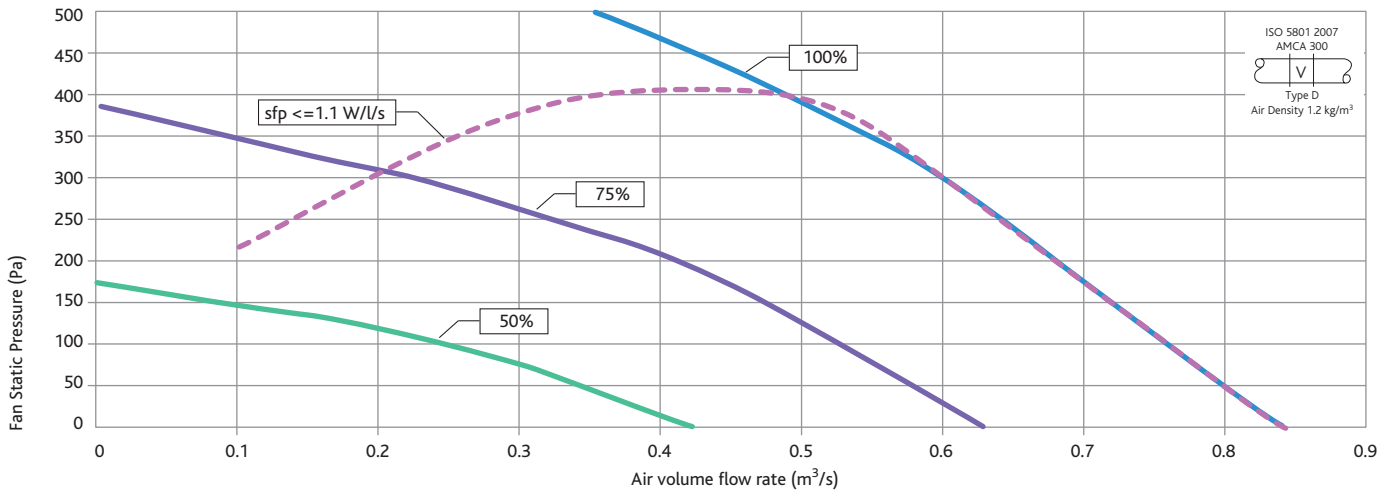

SUPPLY FAN SIZE DS6 - PERFORMANCE

Fan Speed	External Static Pressure (Pa)						
	0	100	200	300	400	500	
100%	Airflow (m³/s)	0.84	0.76	0.68	0.6	0.49	0.35
	SFP (W/l/s)	0.558	0.632	0.718	0.857	1.052	1.448
75%	Airflow (m³/s)	0.63	0.52	0.4	0.22		
	SFP (W/l/s)	0.314	0.413	0.538	0.980		
50%	Airflow (m³/s)	0.42	0.245				
	SFP (W/l/s)	0.139	0.263				

For accurate figures, please refer to Nuair Fan Selection Programme at www.nuair.co.uk, alternatively call Nuair on (029 2085 8200).

Unit Code	Voltage/phase Frequency	Input Power (kW)	FLC/SC (A)	Fan Speed (RPM)	Unit Weight (kg)	Packed Weight (kg)	Pallet/Crate Dimensions (mm)
DS6A-NES	230 / 1 / 50	0.45	2.9 / 2.9	1710	80	120	1400 L x 1400 W x 611 H
DS6A-LES	230 / 1 / 50	0.45	2.9 / 2.9	1710	110	150	1400 L x 1400 W x 611 H
DS6A-EES*	230 / 1 / 50	9.45	42.9 / 42.9	1710	90	140	1400 L x 1400 W x 611 H

*Includes 9 kW Electric Heater.

SUPPLY FAN SIZE DS6 - SOUND DATA

Unit Code		Sound Power Levels dB re 1pW								Breakout dBA @ 100% @ 3m	LwA	Breakout dBA @ 75% @ 3m	Breakout dBA @ 50% @ 3m
		63	125	250	500	1K	2K	4K	8K				
DS6A-NES	Induct Inlet	82	79	79	73	62	60	58	53	39	74	33	24
	Induct Outlet	89	81	74	64	62	59	55	48		71		
	Breakout	69	60	68	54	49	40	35	29		78		
DS6A-LES	Induct Inlet	82	79	79	73	62	60	58	53	39	74	33	24
	Induct Outlet	89	81	74	64	62	59	55	48		71		
	Breakout	69	60	68	54	49	40	35	29		78		
DS6A-EES	Induct Inlet	82	79	79	73	62	60	58	53	39	74	33	24
	Induct Outlet	89	81	74	64	62	59	55	48		71		
	Breakout	69	60	68	54	49	40	35	29		78		

SUPPLY FAN SIZE DS6 - DATA LPHW 82/71 (Deg C)

Unit size	Airflow (m³/s)	Output (kW)	Air Off Temp (°C)	Water flow (l/s)	Coil ΔP (kPa)*	Pipe Connection (mm)	Valve ΔP (kPa)**
6	0.84	32.2	31.9	0.72	11	22	20

*Liquid ΔP ** Minimum Starting ΔP Data based 0 Degree C Air on temperature.

SUPPLY FAN SIZE DS6 - DIMENSIONS (mm)

Unit Code	Ecosmart control						
	A	B	C	D (Dia)	G	H	J
DS6A-NES	1155	1092	455	400	370	150	100
DS6A-LES	1155	1092	455	400	430	175	190
DS6A-EES	1155	1092	455	400	430	155	155

Access for Maintenance: Allow 455mm either above or below the unit.

For control box access allow a minimum clearance of 600mm from a wall or barrier.

Removable weatherproof control cover (if required).

NES: 470mm wide x 173mm high x 120mm deep.
LES: 649mm wide x 323mm high x 281mm deep.
EES: 530mm wide x 178mm high x 175mm deep.

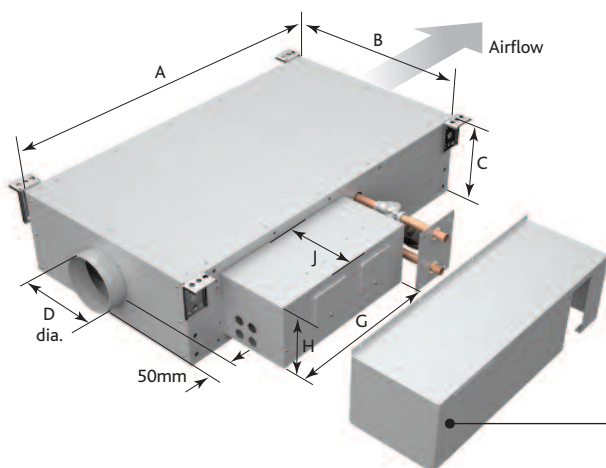

DAVE SUPPLY FANS (SIZE DS7 UNIT)

PERFORMANCE & TECHNICAL INFORMATION

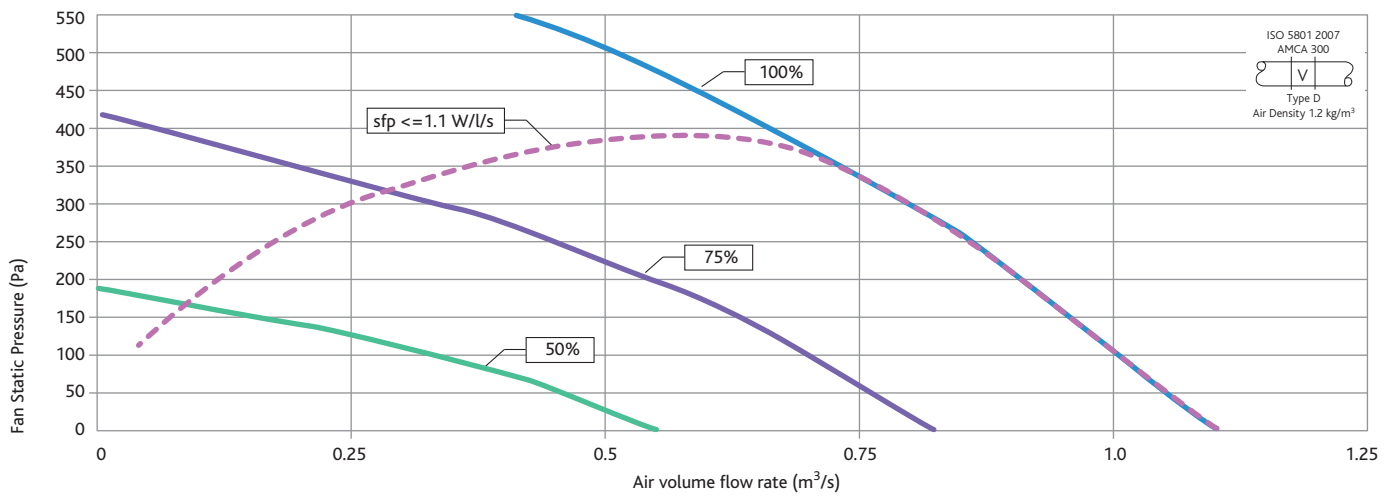

SUPPLY FAN SIZE DS7 - PERFORMANCE

Fan Speed		External Static Pressure (Pa)					
		0	100	200	300	400	500
100%	Airflow (m³/s)	1.1	1.0	0.91	0.8	0.66	0.51
	SFP (W/l/s)	0.631	0.718	0.808	0.947	1.148	1.480
75%	Airflow (m³/s)	0.825	0.7	0.54	0.33	0.06	
	SFP (W/l/s)	0.355	0.443	0.574	0.94	5.17	
50%	Airflow (m³/s)	0.55	0.33				
	SFP (W/l/s)	0.158	0.287				

For accurate figures, please refer to Nuair Fan Selection Programme at www.nuair.co.uk, alternatively call Nuair on (029 2085 8200).

Unit Code	Voltage/phase Frequency	Input Power (kW)	FLC/SC (A)	Fan Speed (RPM)	Unit Weight (kg)	Packed Weight (kg)	Pallet/Crate Dimensions (mm)
DS7A-NES	230 / 1 / 50	0.775	3.5 / 3.5	1650	95	135	1400 L x 1400 W x 656 H
DS7A-LES	230 / 1 / 50	0.775	3.5 / 3.5	1650	120	160	1400 L x 1400 W x 656 H
DS7A-EES*	230 / 1 / 50	9.775	43.5 / 43.5	1650	105	145	1400 L x 1400 W x 656 H

*Includes 9 kW Electric Heater.

SUPPLY FAN SIZE DS7 - SOUND DATA

Unit Code		Sound Power Levels dB re 1pW								Breakout dBA @ 100% @ 3m	LwA	Breakout dBA @ 75% @ 3m	Breakout dBA @ 50% @ 3m
		63	125	250	500	1K	2K	4K	8K				
DS7A-NES	Induct Inlet	82	84	76	71	66	65	61	62	37	75	31	22
	Induct Outlet	87	82	69	66	64	59	57	53		71		
	Breakout	68	63	64	54	52	43	38	36		58		
DS7A-LES	Induct Inlet	82	84	76	71	66	65	61	62	37	75	31	22
	Induct Outlet	87	82	69	66	64	59	57	53		71		
	Breakout	68	63	64	54	52	43	38	36		58		
DS7A-EES	Induct Inlet	82	84	76	71	66	65	61	62	37	75	31	22
	Induct Outlet	87	82	69	66	64	59	57	53		71		
	Breakout	68	63	64	54	52	43	38	36		58		

SUPPLY FAN SIZE DS7 - DATA LPHW 82/71 (Deg C)

Unit size	Airflow (m³/s)	Output (kW)	Air Off Temp (°C)	Water flow (l/s)	Coil ΔP (kPa)*	Pipe Connection (mm)	Valve ΔP (kPa)**
7	1.1	39	29.5	0.87	7	22	20

*Liquid ΔP ** Minimum Starting ΔP Data based 0 Degree C Air on temperature.

SUPPLY FAN SIZE DS7 - DIMENSIONS (mm)

Unit Code	Ecosmart control						
	A	B	C	D (Dia)	G	H	J
DS7A-NES	1155	1200	500	400	370	150	100
DS7A-LES	1155	1200	500	400	430	175	190
DS7A-EES	1155	1200	500	400	430	155	155

Access for Maintenance: Allow 500mm either above or below the unit.

For control box access allow a minimum clearance of 600mm from a wall or barrier.

Removable weatherproof control cover (if required).

NES: 470mm wide x 173mm high x 120mm deep.
LES: 649mm wide x 323mm high x 281mm deep.
EES: 530mm wide x 178mm high x 175mm deep.

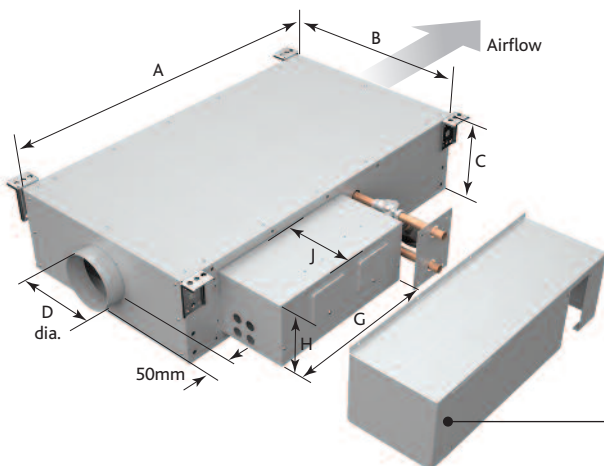

DAVE EXTRACT & SUPPLY FANS ANCILLARIES

FILTERS - G3/G4/F7 (SITE REPLACEMENT)

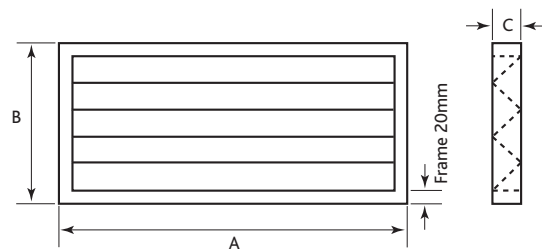

Dimensions (mm)

Unit size	G3 Code	G4 Code	F7 Code	A	B	C
1	D1A-G3FILTERKIT	D1A-G4FILTERKIT	D1A-F7FILTERKIT	445	176	45
2	D2A-G3FILTERKIT	D2A-G4FILTERKIT	D2A-F7FILTERKIT	582	243	45
2H	D2HA-G3FILTERKIT	D2HA-G4FILTERKIT	D2HA-F7FILTERKIT	582	243	45
3	D3A-G3FILTERKIT	D3A-G4FILTERKIT	D3A-F7FILTERKIT	666	254	45
4	D4A-G3FILTERKIT	D4A-G4FILTERKIT	D4A-F7FILTERKIT	722	280	45
4H	D4HA-G3FILTERKIT	D4HA-G4FILTERKIT	D4HA-F7FILTERKIT	722	280	45
5	D5A-G3FILTERKIT	D5A-G4FILTERKIT	D5A-F7FILTERKIT	866	318	45
6	D6A-G3FILTERKIT	D6A-G4FILTERKIT	D6A-F7FILTERKIT	978	363	45
7	D7A-G3FILTERKIT	D7A-G4FILTERKIT	D7A-F7FILTERKIT	1086	408	45

For resistance figures refer to Nuair fan selection programme.

G3 and G4 filters are suitable for Extract Plus fans. G4 and F7 are suitable for Supply Plus fans.

G3 filters are not recommended for Supply Plus fans.

FILTER CASSETTE

Filter Cassettes are constructed from galvanised steel and are fitted with circular spigots. The filter media is of non woven synthetic fibres which are resistant to moisture, fungus, bacteria and frost to G4 specification.

Filter media access panel with quick release clips. **Typical code: SF-100**

Dimensions (mm) & Weights

Code	A	B	C	D	E	Weight Kg	Resistance (Pa) @ Airflow (m³/s)																																			
							.02	.03	.04	.05	.06	.07	0.8	.09	.1	.15	.2	.25	.3	.4	.5	.6	.7	.8																		
SF-150	264	300	184	150	50	3	1	2	3	4	5	5	6	7	8	-	-	-	-	-	-	-	-	-	-	-	-	-	-	-	-	-	-	-	-	-	-	-	-	-		
SF-200	264	350	234	200	50	4	-	1	1	1	2	2	3	3	4	6	8	-	-	-	-	-	-	-	-	-	-	-	-	-	-	-	-	-	-	-	-	-	-	-	-	
SF-250	264	350	284	250	50	6	-	-	1	1	1	2	2	3	3	5	7	9	-	-	-	-	-	-	-	-	-	-	-	-	-	-	-	-	-	-	-	-	-	-	-	
SF-315	264	400	349	315	50	9	-	-	-	1	1	1	1	2	2	3	5	6	7	10	-	-	-	-	-	-	-	-	-	-	-	-	-	-	-	-	-	-	-	-	-	
SF-400	264	900	475	400	50	11	-	-	-	-	-	-	-	-	-	1	2	2	3	4	6	7	8	10	-	-	-	-	-	-	-	-	-	-	-	-	-	-	-	-	-	-

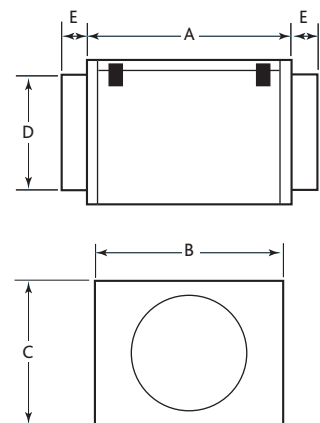

HEAT EXCHANGER (EFFICIENCY UP TO 60%)

Manufactured from galvanised steel. The units provide a means of recovering heat from an extract system and transferring the heat to a complementary air supply system. Designed for horizontal mounting only, consisting of an insulated casing housing a plate heat exchanger. An internal drip tray and drain connection is provided. The access panel can be configured top or bottom. Filters must be fitted upstream on both sides to protect matrix. **Typical code: HX100**

Dimensions (mm) & Weights

Code	A	B	C	D	E	Kg	Resistance (Pa) @ Airflow (m³/s)																																				
							.02	.03	.04	.05	.06	.07	0.8	.09	.1	.15	.2	.25	.3	.4	.5	.6	.7	.8																			
HX150	617	547	216	150	50	15	7	113	21	31	42	55	70	86	104	221	-	-	-	-	-	-	-	-	-	-	-	-	-	-	-	-	-	-	-	-	-	-	-	-	-	-	
HX200	617	547	266	200	50	17	-	12	1	21	26	31	37	43	49	84	140	-	-	-	-	-	-	-	-	-	-	-	-	-	-	-	-	-	-	-	-	-	-	-	-	-	
HX250	617	667	316	250	50	21	-	-	-	2	4	5	8	10	13	32	60	96	141	-	-	-	-	-	-	-	-	-	-	-	-	-	-	-	-	-	-	-	-	-	-	-	
HX315	617	967	381	315	50	26	-	-	-	-	-	-	8	10	12	24	38	60	89	161	256	-	-	-	-	-	-	-	-	-	-	-	-	-	-	-	-	-	-	-	-	-	-
HX400	617	967	466	400	50	31	-	-	-	-	-	-	8	9	10	19	29	42	56	93	137	190	252	323	-	-	-	-	-	-	-	-	-	-	-	-	-	-	-	-	-	-	-

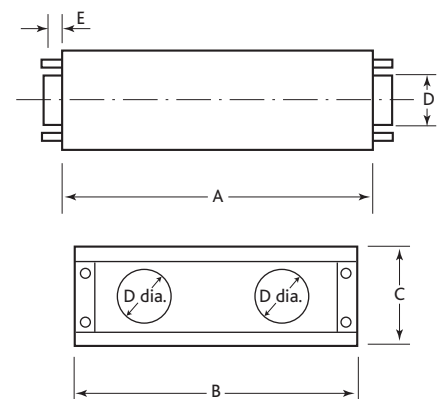

DAVE EXTRACT & SUPPLY FANS ANCILLARIES

ANTI-VIBRATION MOUNTINGS

Supplied as a set of 4. To select match isolated assembly weight to max supporting weight shown on right.

Typical code: NAV1 - Resilient Rubber NAV49 - Spring type.

Dimensions (mm) & Weights

Code	Type	B	C	Max Supporting		
				Weight Kg	Extract	Supply
NAV2	Rubber	40	75	80.0	(Sizes 1 - 6)	(1 - 4H)
NAV3	Rubber	40	75	180.0	(Size 7)	(5)

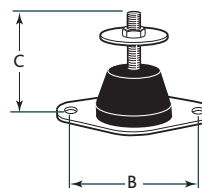

FAST CLAMP

Manufactured from galvanised steel with a gasket liner to provide an air tight joint. Matching fan spigot diameters.

Typical code: FC-100

Dimensions (mm)

Code	A	D	Code	A	D
FC150	90	150	FC315	90	315
FC200	90	200	FC400	90	400
FC250	90	250	-	-	-

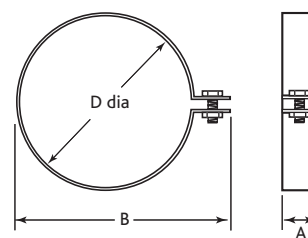

CIRCULAR FLEXIBLE CONNECTOR

Flexible material is flame resistant to BS476 part 7 with galvanised steel spigots. Heat resistant to 132°C with excellent resistance to chemicals, oil and grease. Connector is airtight and waterproof.

Typical code: CFC-10

Dimensions (mm)

Code	A	D	Code	A	D
CFC16	150	152	CFC31	150	317
CFC20	150	202	CFC40	150	402
CFC25	150	252	-	-	-

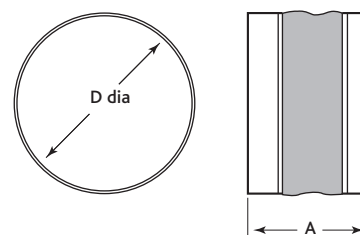

MATCHING FLANGE (SINGLE)

Manufactured from galvanised steel matching flanges are supplied individually.

Typical code: CMF100 (100 = fan diameter in cm).

Dimensions (mm)

Code	Spigot Dia.
CMF150	150
CMF200	200
CMF250	250
CMF315	315
CMF400	400

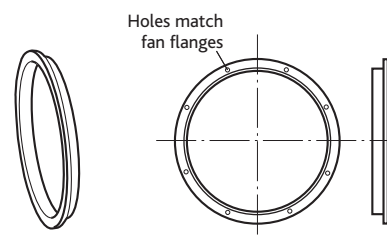

ECOSMART DUCT HEATER

Provided to boost the air temperature if the standard heating is not sufficient. Controlled directly from the Ecosmart Sqrubo controls. Duct Heaters are constructed from galvanised steel, and can be fitted in the horizontal or vertical position. Terminals are provided for electrical connection to heating elements which are centrally located in air stream.

All heaters are fitted with a high temperature safety cut out (rated 13 amps) with a manual re-set button located on the unit terminal box.

Typical code: ESH2

Dimensions (mm) & Weights

Code	Weight					Resistance (Pa) @ Airflow (m³/s)																				
	A	B	C	D	E	Kg	kW/ph	.02	.03	.04	.05	.06	.07	0.8	.09	.1	.15	.2	.25	.3	.4	.5	.6	.7	.8	
ESH2	400	150	200	150	45	3.5	3/1	-	6	11	16	21	26	32	38	45	-	-	-	-	-	-	-	-	-	-
ESH3	400	200	250	200	45	4	3/1	-	-	6	9	12	15	17	20	36	-	-	-	-	-	-	-	-	-	-
ESH4	400	250	300	250	45	5	3/1	-	-	-	-	-	6	8	10	19	28	39	-	-	-	-	-	-	-	-
ESH5	400	315	369	315	45	4.5	3/1	-	-	-	-	-	-	-	-	9	14	20	26	40	-	-	-	-	-	

Note: The Duct Heater requires a separate power supply.

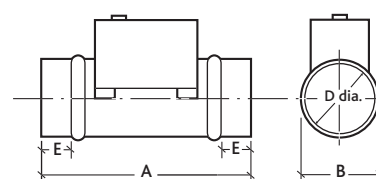

DAVE EXTRACT & SUPPLY FANS ANCILLARIES

SILENCERS - INLINE CIRCULAR

The In-line attenuator shall be constructed in galvanised steel and be fitted with duct work connection spigots. Acoustic media shall be a low density foam to prevent material migration into the airstream.

Typical code: SIL-100

Dimensions (mm) & Weights

Code	A	B	C	D	E	125	250	500	1K	2K	4K	8K	Weight Kg
SIL-150	600	300	184	150	50	-5	-8	-17	-35	-40	-17	-8	6.6
SIL-200	600	350	234	200	50	-9	-8	-14	-29	-23	-12	-14	9.9
SIL-250	600	350	284	250	50	-5	-5	-12	-25	-15	-10	-9	10.9
SIL-315	600	400	349	315	50	-3	-4	-10	-22	-14	-10	-11	12.2
SIL-400	900	700	475	400	50	-4	-9	-11	-14	-10	-8	-6	31.7

Resistance to airflow is negligible.

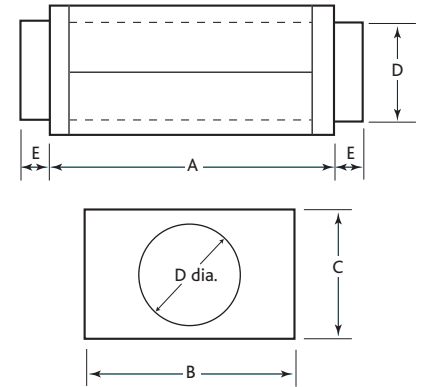

SILENCERS - INLINE CIRCULAR

Attenuators and 'Pods' (when fitted) shall be rigidly constructed from galvanised steel, internally lined with sound absorbing material not less than 100mm thick retained by galvanised steel perforated sheet. Attenuator 'end faces' shall be drilled and tapped to match the flange details of the associated fan. Attenuator 'sound absorbing material' shall be chemically inert, non-combustible, non-hygroscopic and vermin resistant. Attenuator shall be tested in accordance with BS4718:1971 ASTM E 477.

Application: All attenuators shall be suitable for internal and external use at any installed angle. Note: Podded attenuators with higher acoustic performance and other specifications are available. Please contact Nuair Technical for details.

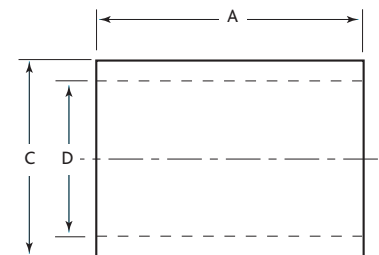

STANDARD UN-PODDED

Dimensions (mm) & Weights

Dynamic Attenuation Octave band mid frequency (Hz)

Code	A	C	D	E	F	G	125	250	500	1K	2K	4K	8K	Weight Kg
CA25S	250	450	250	4	M8	300	-1	-2	-4	-7	-9	-7	-5	6.0
CA31S	315	515	315	8	M8	355	-1	-2	-4	-7	-9	-7	-5	8.0
CA40S	400	600	400	8	M10	450	-2	-3	-5	-7	-9	-6	-5	16.0

Note: Pressure drop is negligible.

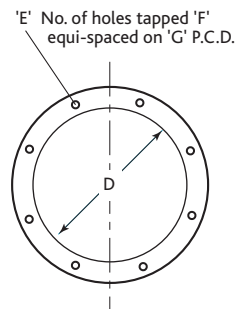

LONG UN-PODDED

Dimensions (mm) & Weights

Dynamic Attenuation Octave band mid frequency (Hz)

Code	A	C	D	E	F	G	125	250	500	1K	2K	4K	8K	Weight Kg
CA25L	500	450	250	4	M8	300	-2	-3	-6	-12	-15	-13	-9	11.0
CA31L	630	515	315	8	M8	355	-2	-3	-6	-12	-15	-13	-9	15.0
CA40L	800	600	400	8	M10	450	-3	-3	-7	-13	-14	-12	-8	30.0

Note: Pressure drop is negligible.

STANDARD PODDED

Dimensions (mm) & Weights

Dynamic Attenuation Octave band mid frequency (Hz)

Code	A	C	D	E	F	G	125	250	500	1K	2K	4K	8K	Weight Kg	Z
CA25SP	250	450	250	4	M8	300	-2	-5	-13	-16	-17	-11	-8	8.0	82
CA31SP	315	515	315	8	M8	355	-3	-6	-14	-16	-17	-11	-8	12.0	26.2
CA40SP	400	600	400	8	M10	450	-3	-7	-14	-18	-16	-11	-8	23.0	8.2

LONG PODDED

Dimensions (mm) & Weights

Dynamic Attenuation Octave band mid frequency (Hz)

Code	A	C	D	E	F	G	125	250	500	1K	2K	4K	8K	Weight Kg	Z
CA25LP	250	450	250	4	M8	300	-4	-10	-21	-27	-29	-19	-12	16.0	82
CA31LP	315	515	315	8	M8	355	-5	-10	-23	-27	-29	-19	-13	22.0	26.2
CA40LP	400	600	400	8	M10	450	-6	-11	-24	-29	-27	-20	-15	43.0	8.2

Note: Air Pressure Drop of Attenuator (Pa) = Z x Q² where Z = Factor listed in table above. Q = Air Volume Flow Rate (m³/s)

DAVE EXTRACT & SUPPLY FANS ANCILLARIES

TERMINATOR COWLS

To provide a weatherproof route for supply & exhaust air to your ducted system.

Cowls are manufactured from flame retardant polymer and can be supplied with gravity backdraught shutters, bird guards and hand guards. The terminal is finished in BS00A05 Grey as standard. All BS or RAL colours are available.

The cowl will normally be fitted to the upstand by a roofing contractor or builder. The Cowl can be fitted without shutters on a 0-60 degree pitched roof with its longer side running down the roof slope. The Cowl can be fitted with its longer side running across a slope of less than 85 degrees from the horizontal. When fitted to a wall the longer side must run horizontal.

Typical code: TRTS-A Note: S = Shutters, BG = Bird Guard

Note: Air Pressure Drop of Attenuator (Pa) = Z x Q² where Z = Factor listed in table below. Q = Air Volume Flow Rate (m³/s)

Dimensions (mm) & Weights

Code	A	B	C	D	E	Weight Kg	Discharge	Z Intake	Z Extract
TRTS-A	900	620	340	460	600	12.3	67	67	118
TRTS-B	1080	740	375	560	695	14.7	39	39	118

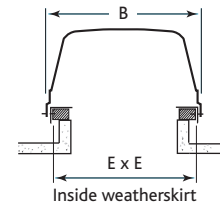
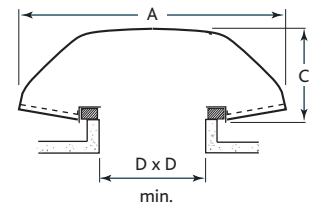

SUPPLY / EXTRACT COWLS

Supply/Extract Cowl: rigid flame retardant cowl, conforming with BS476 (Part 1 class 11) supplied in grey (BS 00 A 05) as standard (any BS or RAL colours available), fixing directly to the base using non-rusting sealed fixings. Air plenum is manufactured from galvanised steel incorporating supply & extract chambers. Rigid spigots are provided for connection of duct work. Supply & extract chamber is fitted with a bird guard. Typical code: TRSE3

Dimensions (mm) & Weights

Code	A	B	C	D	E	F	G	Weight Kg
TRSE3	900	620	340	460	600	200	150	14
TRSE4	1320	964	475	700	945	345	200	30
TRSE5	1320	964	475	700	945	345	250	30
TRSE6	1320	964	475	700	945	345	315	30
TRSE7	1780	1170	485	900	1150	450	400	57

Resistance to airflow of this item is negligible.

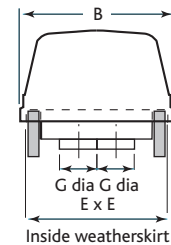
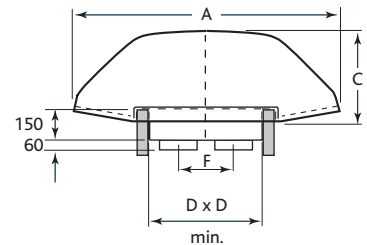

GALVANISED STEEL ROOF COWL

The roof cowl shall be the Nuair type RPC.* The cowl is manufactured from galvanised steel with a bird guard mesh welded in place for reliability and strength. Easy to fit, the cowl will fit directly to spiral or plain circular duct.

When used with Nuair roof pipe flashing a secure terminal through the roof is ensured.

Dimensions (mm) & Weights

Code	A dia.	B dia.	C	Free Area%*	Weight (kg)
RPC-4	100	200	85	138	0.6
RPC-8	200	315	105	131	1.1
RPC-10	250	380	140	119	1.4
RPC-12	315	475	175	122	2.0
RPC-16	400	600	215	125	4.0

*The total openings of the cowl as a percentage of the connecting duct size.

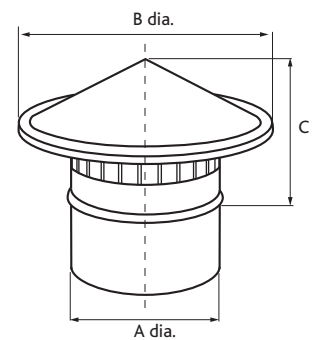

NUAIRE PRODUCTS ACOUSTIC GUIDELINES

IT IS AT LEAST TEN TIMES MORE EXPENSIVE TO CORRECT AN ACOUSTIC PROBLEM THAN TO PREVENT IT.

These laboratory test standards are designed to provide a consistent test method and which to a limited extent that simulate the ways that a fan may be used in a variety of installations.

Nuaire generally quote the noise levels separately for the unit inlet, outlet and casing radiated (or breakout) sources, to enable the system designer to properly evaluate the product in the application.

The noise level measured on site, for example during the commissioning process, is the sound pressure level – and this cannot be directly compared with the sound power levels quoted in our fan selection tools (Nuaire catalogue and Fan Selector).

Nuaire typically also quote a free field dBA level at 3m, and this figure, whilst useful for comparison with other products, has a very specific definition – and cannot be used for acoustic design purposes.

The dBA @ 3m figure quoted will never correspond to a dBA measurement taken at 3m from a product in a real building.

Acoustics is a complicated subject and must be treated with caution as part of the services design process. Our sales engineers and technical support staff will often be able to offer advice on appropriate product types for an application, but it is often necessary to refer to acoustic specialists for a definitive design solution.

Nuaire have put together the following bullet points for your information and assistance:-

SYSTEM DESIGN – GENERAL AND COMMON SENSE ISSUES

- Position the fan for minimum noise impact
- Position grilles and diffusers for minimum noise impact
- Design the system for low pressure drop and smooth air flow = low velocity ducting and grilles etc.
- Where appropriate, use barriers and enclosures of a suitable specification – ensuring that they are properly installed (eg ceiling tiles and bulkheads). Special acoustic grade materials are generally available, and the first principle is to add mass to the system – eg layers of plasterboard.
- Use appropriately specified attenuators and Anti-Vibration mounts – again - properly installed and not bridged to the support structure.
- Flexible or lightweight supporting structures, or slow running fans, can require higher levels of mechanical isolation, and this can only be achieved with high deflection spring type mounts.
- Flexible Connectors are often a particular source of breakout noise – if they must be used in sensitive areas, then an acoustic grade should be specified.

- Single skinned rectangular attenuators can also be vulnerable to breakout at the fan connection – consider this carefully in your specification. Ideally, use attenuators that have been specified with breakout protection, and fit the flexible connectors at inlet attenuator entry and outlet attenuator exit. Any deviation from a straight inlet/outlet condition, whether by crumpled flexible connectors, bends, or offset transformation pieces, will lead to an increase in the quoted in-duct noise levels.
- Specify the correct duty with minimal allowances - and commission the systems properly.

As a very rough "rule of thumb", due to the combined effects of an acoustic room property known as "directivity" and a distance correction for a real room situation, it is possible that the dBA level measured in a room with a ceiling void mounted fan above it, can be increased by 8-9 dBA possibly up to 14 dBA higher than the Free Field figure.

In general terms, a specification of NR 35 or 40 dBA represents a very acceptable level for most people in an office environment.

A requirement to achieve levels of NR 30 or 35 dBA or less in a working space, can be considered as challenging, and may require specialist acoustic assistance. At the very least, with such a specification, the acoustic requirements should be a major design consideration.

Designated "Quiet" areas and bedrooms will need to operate at these levels and preferably lower.

AIRE-VOLVE TWIN FANS

Internal & External options
with Constant Pressure.

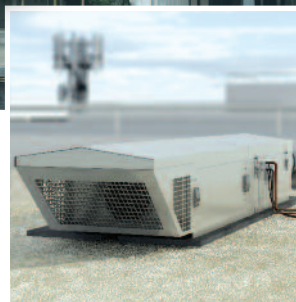

(Model: Aire-Volve AVTCP9-R).
External roof mounted twin fan fitted with
an external unit grille assembly.

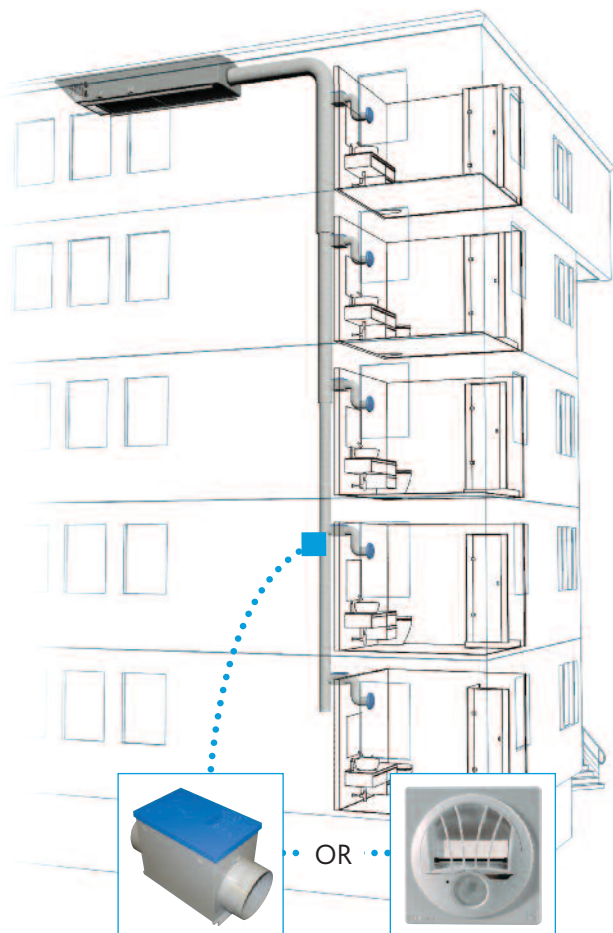

Nuaire Ecosmart Constant Pressure systems are designed for continuous ventilation. They feature Ecosmart on demand control, so costs are kept low.

When a room is occupied, a PIR or switch triggers the damper, which immediately operates as required, returning to background ventilation when the room is vacated.

The Constant Pressure Fan offers up to 70% savings over conventionally controlled central systems and should the primary fan or motor fail, the automatic change over guarantees uninterrupted ventilation because it works at reduced duty the unit consumes less power and is very quiet. This energy efficient ventilation solution is extremely cost effective to run and simple to install as all components are delivered assembled, wired and tested.

Specify Nuaire Ecosmart Constant Pressure and blow away your client's energy bills. Typical applications include Schools, Hotels, Apartments, Nursing Homes and Offices.

Nuaire For the complete ventilation solution.



AIRE-VOLVE SINGLE FANS

Internal options with Constant Pressure.



Features & Benefits

Latest EC motor Technology - Guarantees longer life and lower SFPs.

Double walled panel with 35mm acoustic lining - Ensures lowest breakout.

Built-in Ecosmart control - Energy efficient demand control ventilation solution with 80% controllability allowing the duty to be adjusted if ductwork installation changes during construction on site.



Class L2 Leakage - Units are tested to meet Class L2 leakage. (BS EN 1886 : 2007).

Most compact 'size for duty' case available on the market - Ideal for applications with restricted ceiling voids. Offers either top or bottom access.

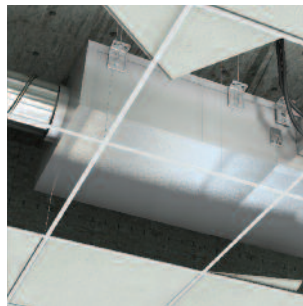

Fully enclosed fan spigot - Fan and matching silencer system reduces breakout and guarantees a superior acoustic solution.

Manufactured from corrosion resistant heavy gauge Aluzinc - Has 5 times longer life than galvanised steel and provides higher wear resistance.

Wide direct duty range - Available up to 1.9m³/s.

Removable unit end panel - Can be attached to matched silencers prior to connection to ducting system.

Designed matched silencers - Matched silencers acoustically designed to work in conjunction with Aire-Volve single fans.

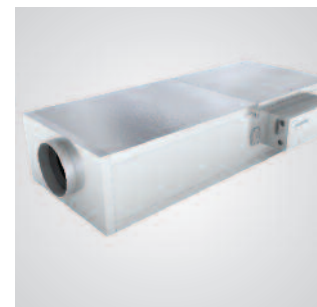

Full accessory range - Includes matched silencers, optional rectangular end panel and dampers.

5 Year Warranty - Peace of mind.



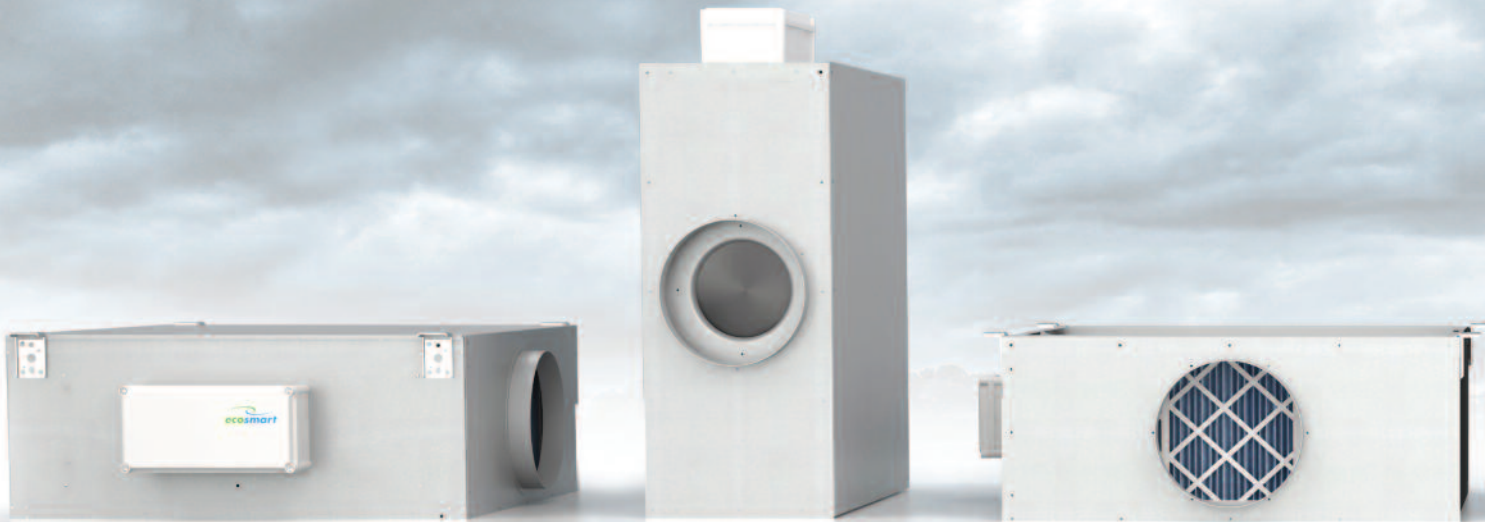

FOR MORE INFORMATION

www.nuaire.co.uk

COMMERCIAL

www.nuaire.co.uk/commercial



NUAIRE LIMITED

Western Industrial Estate | Caerphilly | CF83 1NA

t +44 (0)29 2085 8200 | f +44 (0)29 2085 8222 | e info@nuaire.co.uk

www.nuaire.co.uk

As part of our policy of continuous product development Nuaire reserves the right to alter specifications without prior notice. Telephone calls may be recorded for quality and training purposes.

Part Number 671675 April 2015. (Issue 2)