

UPTON SERIES BOILERS

Floor Standing, Condensing , Open Flue,
Fully Modulating, Pre-Mix,
Gas Fired Boilers for Heating & Domestic
Hot Water Installations

Installation, Commissioning and Operating Instructions

Models:

UF100-1, UF150-1, UF200-1, UF250-1, UF300-1 UF350-1
UF200-2, UF300-2, UF400-2, UF500-2, UF600-2 UF700-2
UF300-3, UF450-3, UF600-3, UF750-3, UF900-3 UF1050-3

NATURAL GAS I_{2H}
LPG Propane I_{3P}

IMPORTANT NOTE

**THESE INSTRUCTIONS MUST BE READ AND
UNDERSTOOD BEFORE INSTALLING,
COMMISSIONING, OPERATING OR SERVICING
EQUIPMENT**

Customer After Sales Services

Telephone: **0845 450 2866** E-mail: **aftersales@hamworthy-heating.com** Fax: **01202 662522**

Technical Enquiries

To supplement the detailed technical brochures, technical advice on the application and use of products in the Hamworthy Heating range is available from our technical team in Poole and our accredited agents.

Site Assembly

Hamworthy offer a service of site assembly for many of our products in instances where plant room area is restricted. Using our trained staff we offer a higher quality of build and assurance of a boiler built and tested by the manufacturer.

Commissioning

Commissioning of equipment by our own engineers, accredited agents or specialist sub – contractors will ensure the equipment is operating safely and efficiently.

Maintenance Agreements

Regular routine servicing of equipment by Hamworthy service engineers inspects the safety and integrity of the plant, reducing the risk of failure and improving performance and efficiency. Maintenance agreements enable our customers to plan and budget more efficiently.

Breakdown service, repair, replacement

Hamworthy provide a rapid response breakdown, repair or replacement service through head office at Poole and accredited agents throughout the UK.

Spare Parts

A comprehensive spare parts service is operated from our factory in Poole, providing replacement parts for both current and discontinued products. Delivery of parts and components is normally from stock within seven days. However, a next day delivery service is available for breakdowns and emergencies.

UPTON SERIES BOILERS

Floor Standing, Condensing , Open Flue,
Fully Modulating, Pre-Mix,
Gas Fired Boilers for Heating & Domestic
Hot Water Installations

Installation, Commissioning and Operating Instructions

Models:

UF100-1, UF150-1, UF200-1, UF250-1, UF300-1 UF350-1
UF200-2, UF300-2, UF400-2, UF500-2, UF600-2 UF700-2
UF300-3, UF450-3, UF600-3, UF750-3, UF900-3 UF1050-3

NATURAL GAS I_{2H}
LPG Propane I_{3P}

NOTE: THESE INSTRUCTIONS MUST BE READ AND UNDERSTOOD BEFORE INSTALLING, COMMISSIONING, OPERATING OR SERVICING EQUIPMENT.

THE UPTON BOILER IS INTENDED FOR USE AS A COMMERCIAL APPLIANCE AND IS NOT CERTIFIED FOR USE IN DOMESTIC APPLICATIONS.

THIS BOILER IS FOR USE ON GROUP H NATURAL GAS (2ND FAMILY) I_{2H} AND LPG PROPANE (3RD FAMILY) I_{3P}. PLEASE ENSURE RELEVANT INFORMATION REQUIRED WITHIN DOCUMENT IS FOUND BEFORE FIRING BOILER.

COUNTRY OF DESTINATION : UNITED KINGDOM & REPUBLIC OF IRELAND

THIS BOILER COMPLIES WITH ALL RELEVANT EUROPEAN DIRECTIVES.
PRODUCT IDENTIFICATION No. 86CS33

PUBLICATION NO. 500001340
ISSUE B
MONTH July 2017

CONTENTS

PAGE

1.0	INTRODUCTION	1
2.0	SUPPLY AND DELIVERY	3
3.0	SIZE AND SPACE REQUIREMENTS	5
4.0	SITE LOCATION AND PREPARATION	13
4.1	Site Location	
4.2	Gas Supply	
4.3	Flue System	
4.4	Water Supply - including heat exchanger warranty conditions	
4.5	Condensate Connections	
4.6	Electrical Supply	
5.0	BOILER ASSEMBLY	18
5.1	General	
5.2	Water Connections	
5.3	Flue Connections	
5.4	Sealed Systems	
5.5	Electrical Connections	
6.0	PRE-COMMISSIONING	19
6.1	Gas Supply	
6.2	Ventilation	
6.3	Pipework, Valves and Pump	
6.4	Flue	
6.5	Electrical	
7.0	CHECKS PRIOR TO LIGHTING	21
7.1	Boiler Gas System Leak Check	
7.2	Checks Prior to Lighting the Boiler	
7.3	Commissioning the Boiler	
8.0	INITIAL LIGHTING	22
8.1	Operational Checks	
8.2	Controls Operation	
8.3	Ignition Controller Check	
8.4	Gas Pressure Check	
8.5	Combustion Checks	
8.6	User Instructions	
9.0	FAULT FINDING	28
9.1	Safety Temperature Limiter (Limit Thermostat)	
9.2	Ignition Controller	
9.3	Water Flow Switch	
10.0	SERVICING	30
11.0	REPLACEMENT OF FAILED COMPONENTS	32
12.0	RECOMMENDED SPARES	34

APPENDICES

APPENDIX A	GAS DATA	33
APPENDIX B	ELECTRICAL CONNECTIONS AND CONTROLS	34
APPENDIX C	FLUE DATA	36
APPENDIX D	VENTILATION	39
APPENDIX E	WATER DATA	41

PICTORIAL AND DIAGRAMMATICAL DATA

Figure 2.1	Boiler Packaging	3
Figure 2.2	Boiler Package Dimensions	4
Figure 3.1.1	Dimensions and clearances UF100—UF150.....	5
Figure 3.1.2	Dimensions and clearances UF200—UF250.....	6
Figure 3.1.3	Dimensions and clearances UF300—UF350.....	7
Figure 3.2.1	Primary circuit and Gas Manifold pipe kit.....	8
Figure 3.2.2	UF100 & UF150 2MW Primary circuit and Gas manifold pipe kit	9
Figure 3.2.3	UF200 & UF250 3MW Primary circuit and Gas manifold pipe kit	10
Figure 3.2.4	UF300 & UF350 2MW Primary circuit and Gas manifold pipe kit	11
Figure 3.2.5	UF300 & UF350 4MW Primary circuit and Gas manifold pipe kit	12
Figure 3.3	Pipe kit data.....	13
Figure 4.2	Gas connection	13
Figure 4.4	Water connections.....	15
Figure 4.5.1	Boiler condensate connection	16
Figure 4.6	Navistem Electrical Connections.....	17
Figure 7.1	Gas system leak check	20
Figure 7.2.1	On / OFF Switch.....	21
Figure 8.3.1	Operating phases	23
Figure 8.5.1	Combustion analyser probe setting.....	24
Figure 8.5.2	Insertion of analyser probe.....	24
Figure 8.5.3	Combustion settings.....	25
Figure 8.5.4	General overview of boiler controls.....	27
Figure 9.3.1	Wiring Schematic	29
Figure 10.2.1	Spark electrode position.....	31
Figure 10.2.2	Flame sensing probe position	31
Figure 11.11	Air Pressure switch.....	33
Figure 11.12	Air Filter media	33

APPENDIX**PAGE**

Figure A1	Gas Data	35
Figure A2	General Data	35
Figure A3	Product information - ErP Regulation (813/2013)	36
Figure B1	Electrical Supply	37
Figure B1.2	External Control Wiring for Multiple Boiler Installation	38
Figure B1.3	Sensor resistance values	39
Figure C1	Flue Data	40
Figure D1	Mechanical Ventilation Flow Rates	44
Figure E1	Water Data	44
Figure E1.1	Hydraulic Resistance.....	44
Figure E1.3.1	Schematic 1 - External time clock enabled boiler	47
Figure E1.3.2	Schematic 2 -Two heating circuits with DHW & boiler shunt pump	47
Figure E1.3.3	Schematic 3 - Master and slave sequence control with reverse return primary	48
Figure E1.3.4	Schematic 4 - Reverse return primary circuit	48
Figure E1.3.5	Schematic 5 -Primary circuit with individual boiler shunt pumps	49
Figure E1.3.6	Schematic 6 - Reverse return primary circuit with individual motorised boiler isolation	49

1.0 INTRODUCTION

1.1 This boiler must be installed by a competent person. Please read the technical and user instructions before installing and lighting the boiler. All installations **MUST** conform to the relevant Gas Safety and Building Regulations. Health & Safety requirements must also be taken into account when installing any equipment. Failure to comply with the above may lead to prosecution.

This appliance is not intended for use by persons (including children) with reduced physical, sensory or mental capabilities, or lack of experience and knowledge, unless they have been given supervision or instructions concerning cleaning, maintenance and use of the appliance by a person responsible for their safety. Children should be supervised to ensure that they do not play with the appliance.

1.2 This boiler is intended for use on Group H Natural Gas (2nd Family) I_{2H} or LPG Propane (3rd Family) I_{3P}. The firing information is to be found in Appendix 'A'. Boilers **MUST NOT** use gas other than that for which they are designed and adjusted.

1.3 The Upton is a gas fired, fully modulating, condensing, fan assisted, open flued central heating / hot water boiler. Using the latest gas / air ratio control technology it is able to provide clean efficient operation across a large output range.

1.3.1 The boiler can be supplied in a modular format, a maximum of three vertically stacked modules being arranged into a single unit sharing a common flue.

1.3.2 Each boiler module utilises a metal fibre, fan assisted, pre-mix burner.

1.3.3 Operation is initiated and controlled by a Navistem boiler management system with a user interface LCD display for accessing and changing boiler parameters.

1.3.4 Each of the boiler models is designed for direct connection to a flue system. The Technical Data is given in Appendix 'C'. The flue outlets from more than one unit may be connected to a single chimney. No draught diverter is fitted to the boiler nor is a fixed diverter required in the flue system. However a draught stabiliser may be required for some installations.

1.3.5 The Upton is floor mounted and is intended for the heating of Commercial and Industrial premises. It may also be used to supply hot water for these premises via an indirect cylinder.

1.3.6 The Upton has a low water content and water flow rates **MUST** be maintained at or above the recommended levels shown in Appendix 'E'.

1.4 This boiler must be connected an un-vented (pressurised) heating system, it must not be used on open vented systems. Care must be taken to ensure all extra safety requirements are satisfied and that the relevant interlocks will shut the boiler(s) off should a high or low pressure fault occur.

1.4.1 The pressurisation unit must also incorporate a low level water switch which protects the water pumps and will directly or indirectly shut down the boiler plant should a low water condition occur.

1.4.2 Consideration should also be given to the maximum working pressure of the boiler as given in Appendix 'E'. Consult Hamworthy Heating Technical Department for help or assistance if in doubt.

1.5 The Upton boiler is not suitable for direct connection to domestic hot water supplies.

1.6 The Upton boiler can be installed with reverse return water flow, (optional HHL pipe kits are available, complete with individual shut pumps and low loss header for up to 12 modules in two or three vertically stacked units). See Appendix 'E', figure E1.1 for typical schematic layouts

1.7 Regulatory disposal and managed recycling of this product can prevent damage to the environment and health risks.

a) For the disposal of the product and the component parts, the services of an accredited waste disposal company should be used.

b) For more information on waste disposal/management, contact the Local Authority responsible for waste management or the point of sales where the product was purchased.

1.8 BOILER MODELS

1, 2 or 3 high models

Upton UF100-1	Single 100kW module
Upton UF200-2	Two 100kW vertically stacked modules
Upton UF300-3	Three 100kW vertically stacked modules
Upton UF150-1	Single 150kW module
Upton UF300-2	Two 150kW vertically stacked modules
Upton UF450-3	Three 150kW vertically stacked modules
Upton UF200-1	Single 200kW module
Upton UF400-2	Two 200kW vertically stacked modules
Upton UF600-3	Three 200kW vertically stacked modules
Upton UF250-1	Single 250kW module
Upton UF500-2	Two 250kW vertically stacked modules
Upton UF750-3	Three 250kW vertically stacked modules
Upton UF300-1	Single 300kW module
Upton UF600-2	Two 300kW vertically stacked modules
Upton UF900-3	Three 300kW vertically stacked modules
Upton UF350-1	Single 350kW module
Upton UF700-2	Two 350kW vertically stacked modules
Upton UF1050-3	Three 350kW vertically stacked modules

1.9 The fully assembled unit is supplied covered with a protective sleeve. The flue assemblies for the stacked models are supplied separate packs.

1.10 Each Upton module can be controlled by a 0-10V analogue control input capability which is available via the Navistem boiler control.

1.11 Options - refer to individual kit instructions for details

1.11.1 Optional water pipe work kits are available for two or three high vertical units for up to 12 modules. These kits are free-standing allowing installation to the system prior to installing the boiler and incorporate all necessary valves, inter connecting pipework, and flow and return headers. Refer to individual kit instructions for details.

1.11.2 Controls peripherals

The Navistem boiler management system has the potential to accept the following control options:

1.11.2.1 Clip in Fault Alarm & Run Signal AGU2.550A109

Optional kit for a Run/Fault signal.

(available as a kit from Hamworthy Heating Ltd)

Kit Part No. 563605666

1.11.2.2 Clip in LPB Bus comms OCI345

LPB sequencing of the cascade controlled by Merley / RVS

(available as a kit from Hamworthy Heating Ltd)

Kit Part No. 563605667

1.11.2.3 Additional kits available from Hamworthy Heating :

1 Zone Heating Circuit Kit - 563605692

2 Zone Heating Circuit Kit - 563605693

3 Zone Heating Circuit Kit - 563605694 (Note: cannot be used in conjunction with Fault Alarm & Run Signal Clip-In Kit)

Additional Heating Circuit Kit - 563605673

Outside Air Temperature Sensor - 533901457

Room Sensor QAA55 - 563605696

Room Sensor QAA75 - 563605695

Merley Sequence Controller - Loose Kit 563605671 or Fully Assembled 563605672

(Allows cascade management of up to 16 boilers, and interface with a BMS system)

2.0 SUPPLY AND DELIVERY

The boiler is despatched to site as a pre-assembled and tested unit. Each boiler is delivered by a tail lift vehicle and lowered to ground level. It is the installers responsibility to convey the boiler to the plantroom and to remove it from the pallet.

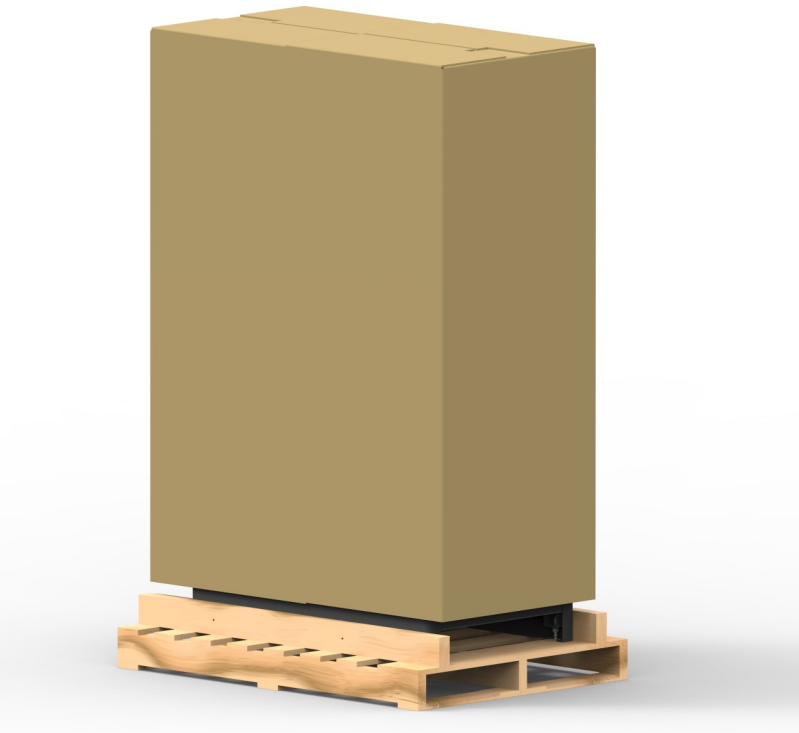

NOTE: The Upton boilers **MUST** not be stacked. When handling and manoeuvring the boiler care must be taken to avoid damage to the casing. The flue system is packaged separately.

The boiler must be kept upright during handling.

The flue manifold connecting the vertical modules is supplied separately to the boiler .

Warranty

Full warranty assistance will be covered when the appliance is commissioned by Hamworthy Heating Ltd, see Terms & Conditions for full details.

Hamworthy Heating Ltd will not accept any liability resulting from damage due to tampering, improper use, handling, installation errors, operation and maintenance. It is important to check for damage upon receipt of product, which if found must be notified to Hamworthy Heating Ltd immediately.

In the event of failure or breakdown, isolate the equipment and contact Hamworthy Technical Support
Tel - 0845 450 2866

Figure 2.2 - Boiler Packaged Dimensions

Model	H mm	W mm	D mm	Weight (kg)
UF100-1	922	1000	1200	152
UF200-2	1536	1000	1200	286
UF300-3	2150	1000	1200	420
UF150-1	922	1000	1200	177
UF300-2	1536	1000	1200	336
UF450-3	2150	1000	1200	495
UF200-1	922	1000	1200	220
UF400-2	1536	1000	1200	422
UF600-3	2150	1000	1200	624
UF250-1	922	1000	1200	247
UF500-2	1536	1000	1200	476
UF750-3	2150	1000	1200	705
UF300-1	922	1000	1400	287
UF600-2	1536	1000	1400	551
UF900-3	2150	1000	1400	815
UF350-1	922	1000	1400	310
UF700-2	1536	1000	1400	597
UF1050-3	2150	1000	1400	884
Flue manifold	700	500	500	11

Delivery Verification

When taking delivery please ensure that you have received the correct number of boilers and individual flue kits to fulfil your order. If any item is missing please contact our after sales service team. Please provide details of your order such as order number and contract number as well as a detailed description of the missing item.

Frame Set and Pipe work Header Kits

Where pipe work kits are supplied, these are packaged separately from the boilers. All ancillary items such as isolation valves and boiler make-up connectors are factory fitted and tested The whole is shrink wrapped for security and basic protection. Refer to Kit instructions 500005162

3.0 SIZE AND SPACE REQUIREMENTS

3.1 The Upton boiler range has been designed to utilise minimum floor space, therefore it is important that the plant room has sufficient ceiling height to allow for installation and connection to the flue system allowing for sufficient access at sides and behind boiler for pipe work connections. See Figure 3.1

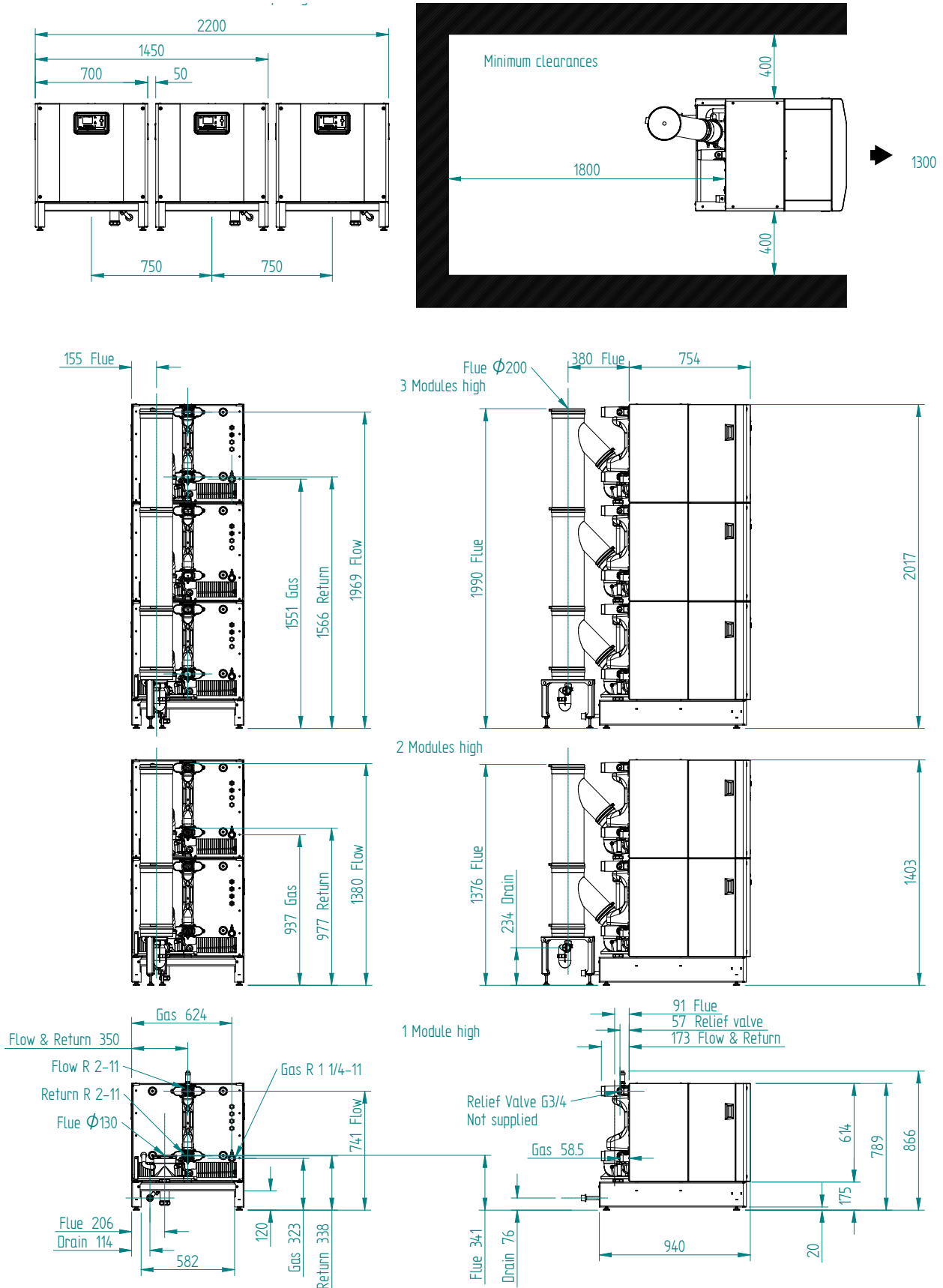

Figure 3.1.1 - Dimensions and Clearances UF100 & 150

Figure 3.1.2 - Dimensions and Clearances UF200 & 250

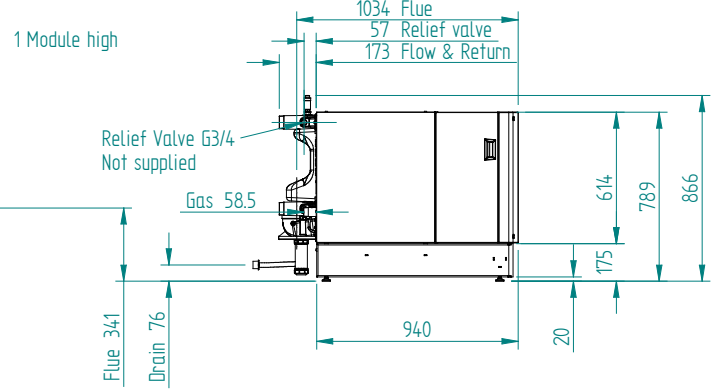
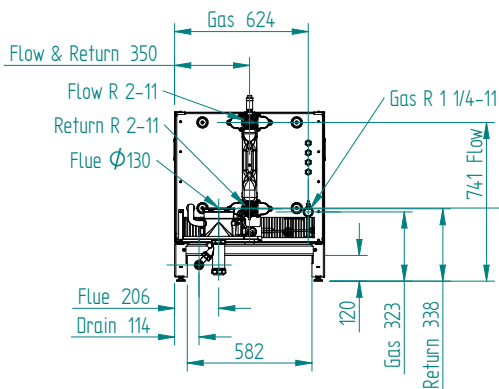
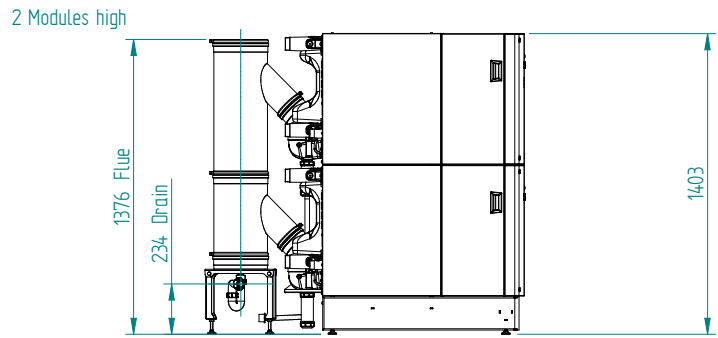
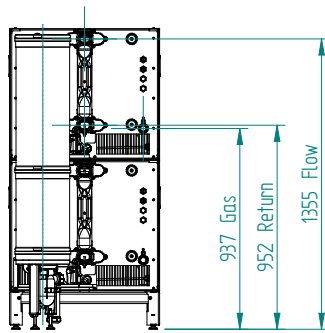
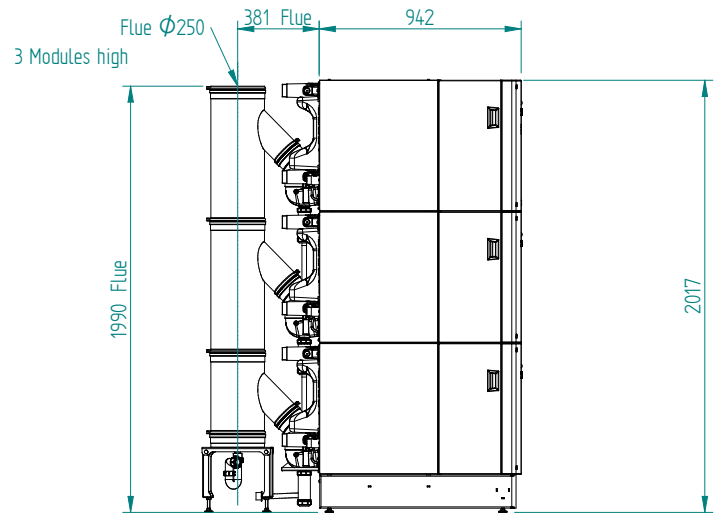
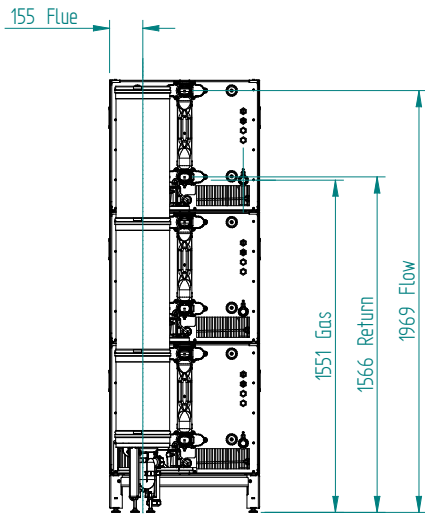
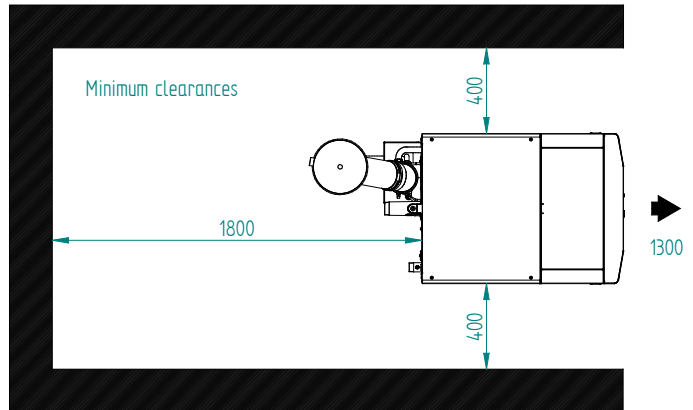
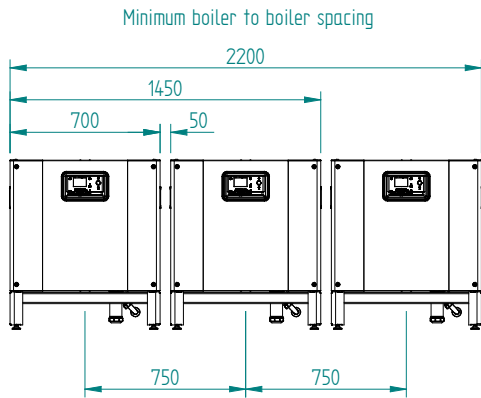
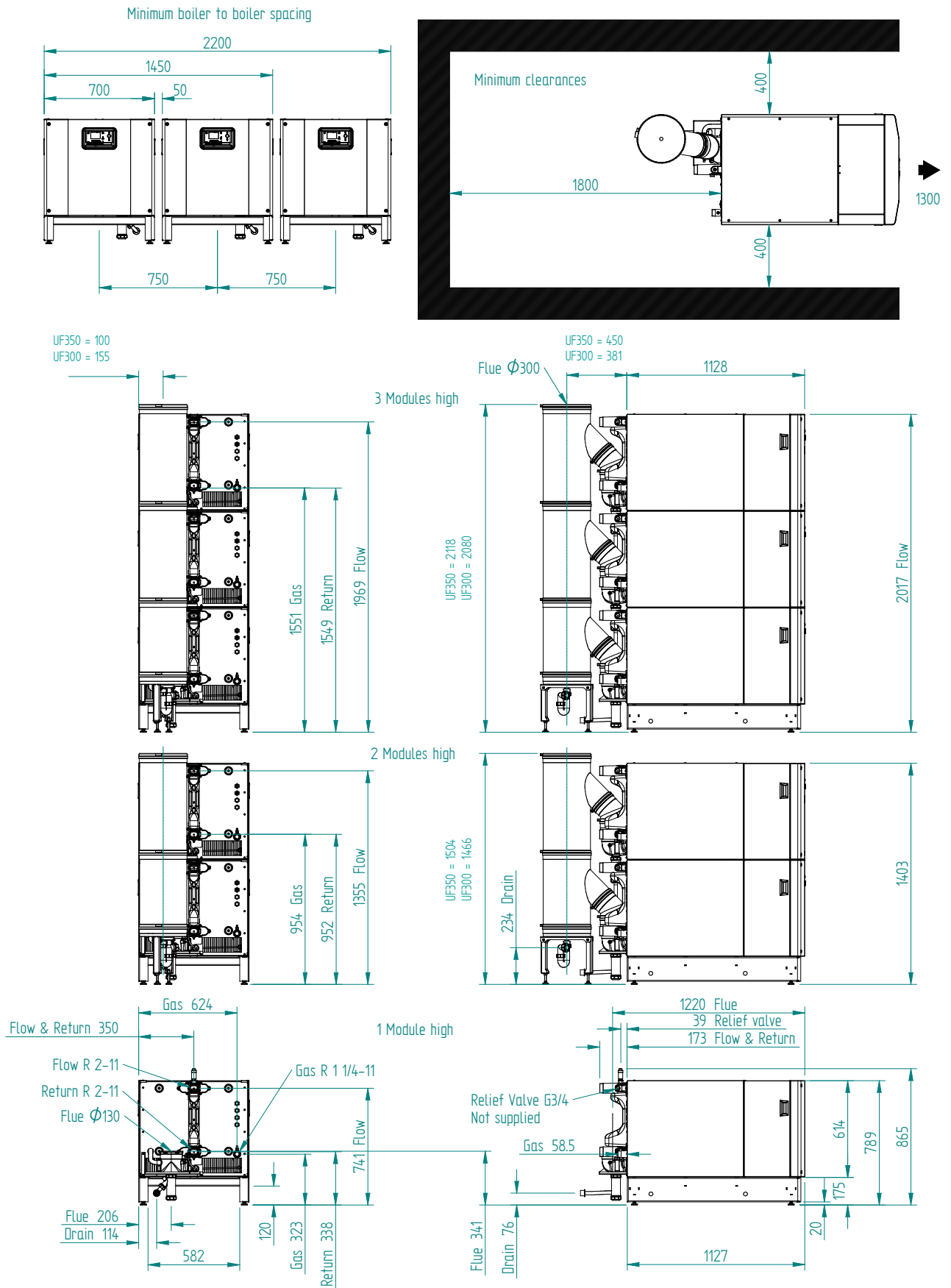

Figure 3.1.3 - Dimensions and Clearances UF300 & 350



3.2 The Hamworthy Heating Ltd pipe work kit is designed to provide a complete primary circuit system for two and three high stacked modules. Multiple stacked units can be connected together to provide large output arrays. See the following pages for the size and number of modules that can be connected together. There is no pipe work kit option for single boiler modules. The basic kit consists of a flow and return manifold to which can be fitted a combined low loss header and dirt air separator, blanking flanges and a secondary manifold for three heating circuits.

- The flow and return manifold is supplied with matched primary circuit pumps, isolating valves, gas manifold, condensate drain and boiler safety relief valves. An automatic air vents is fitted to the top of the flow header and the vertical flow and return manifold have connection points for flushing the system, plus drain and air bleed valves. Flexible hoses connect the manifold to the flow and return ports on the boilers. Non return valves on the pump supply prevent reverse flow through non firing modules.
- The combined low loss header and dirt air separator has an adjustable support stand, sensor pockets in the flow and return ports to control the mixed flow temperature, automatic air vent and drain valve for sludge removal. The low loss header can be fitted to either the side of the flow and return pipe kit using the flanged pipes supplied.
- Blanking flanges for the flow and return headers are provide with connection points for system safety relief valve in the top flange and for an expansion vessel and/ or pressurisation unit in the lower flange.
- The secondary circuit manifold allows for up to three separate heating circuits to be connected to the low loss header. Fixing bolts and gaskets are provided with the manifold.

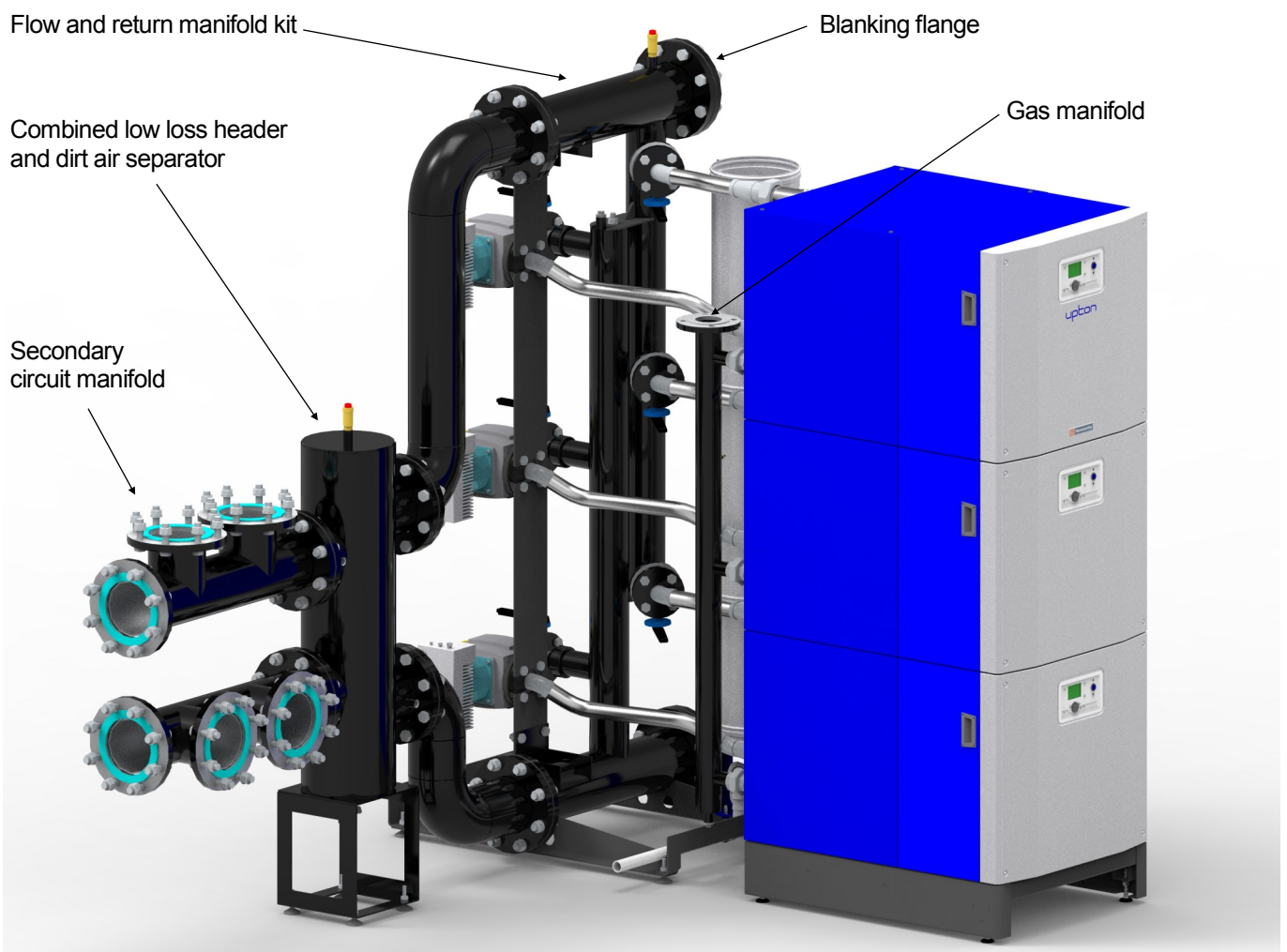
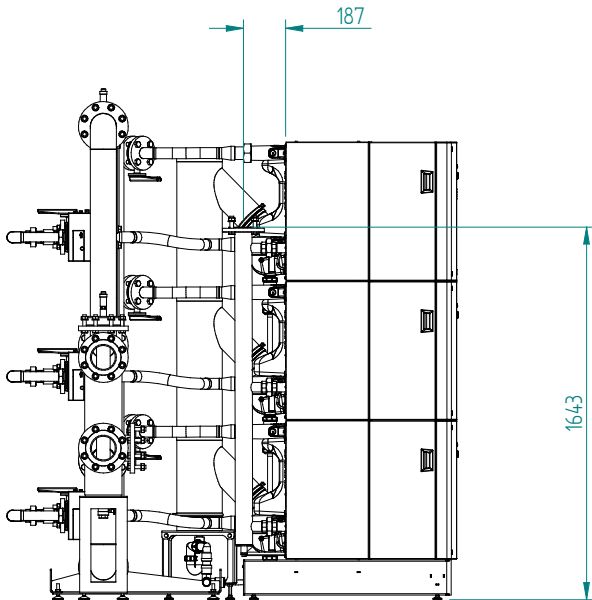
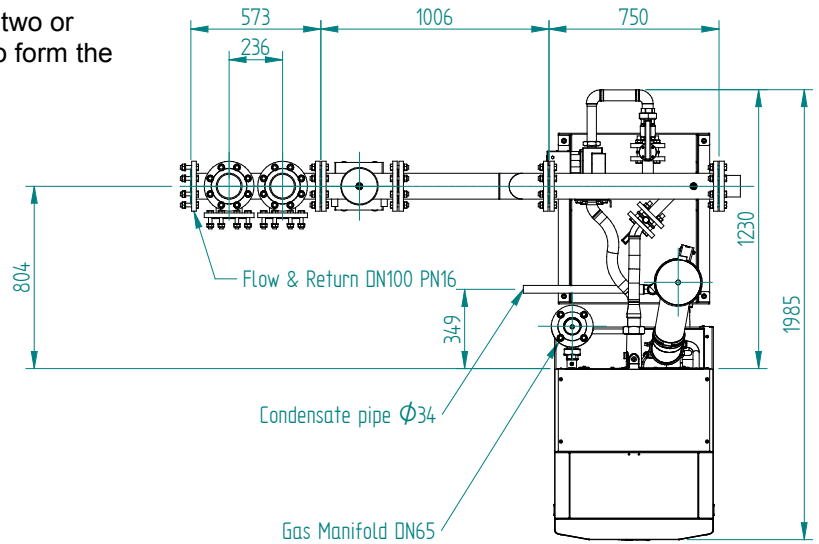

Figure 3.2.1 – Primary circuit and Gas manifold pipe kit

UF100 & UF150 DN100 2MW Primary circuit and Gas manifold pipe kit

The pumps are sized to allow 12 modules in two or three high stacks to be connected together to form the primary circuit.



R3" System Safety Relief Valve

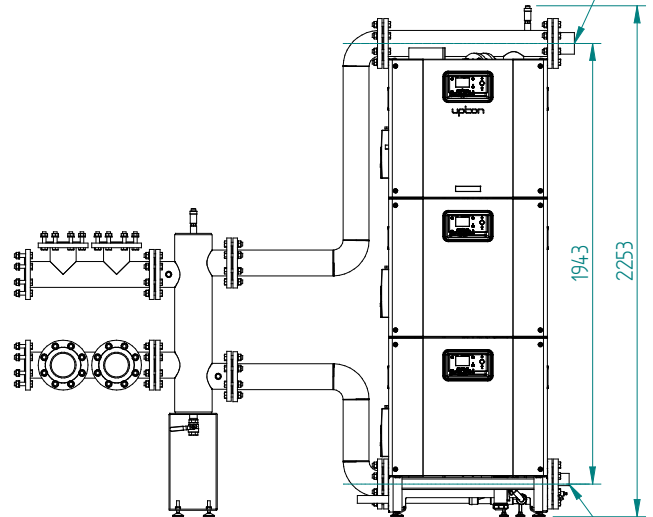

G15" Pressurisation unit & Expansion Vessel

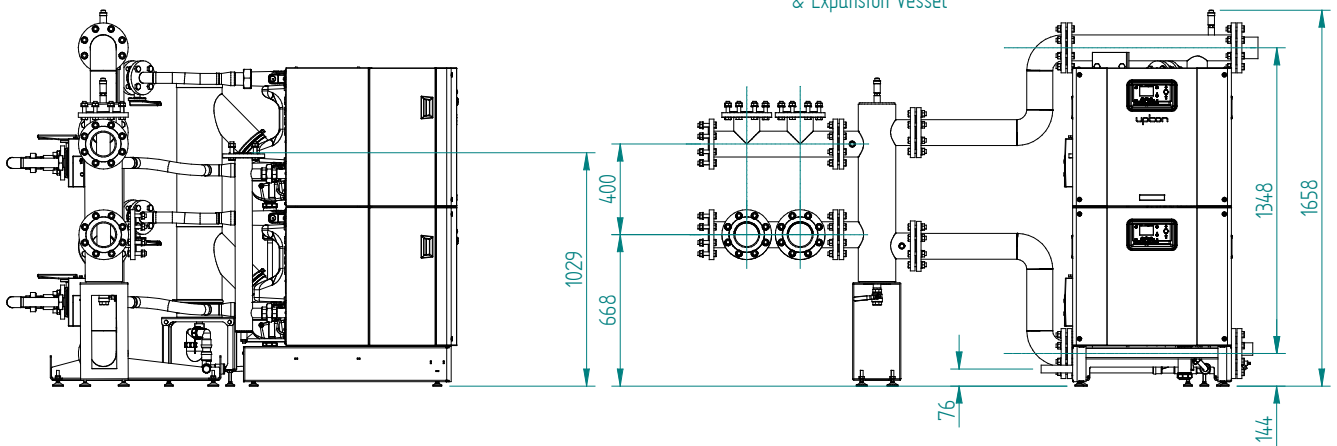

Figure 3.2.2 – UF100 & UF150 2MW Primary circuit and Gas manifold pipe kit

UF200 & UF250 DN150 3MW Primary circuit and Gas manifold pipe kit

The pumps are sized to allow 12 modules in two or three high stacks to be connected together to form the primary circuit.

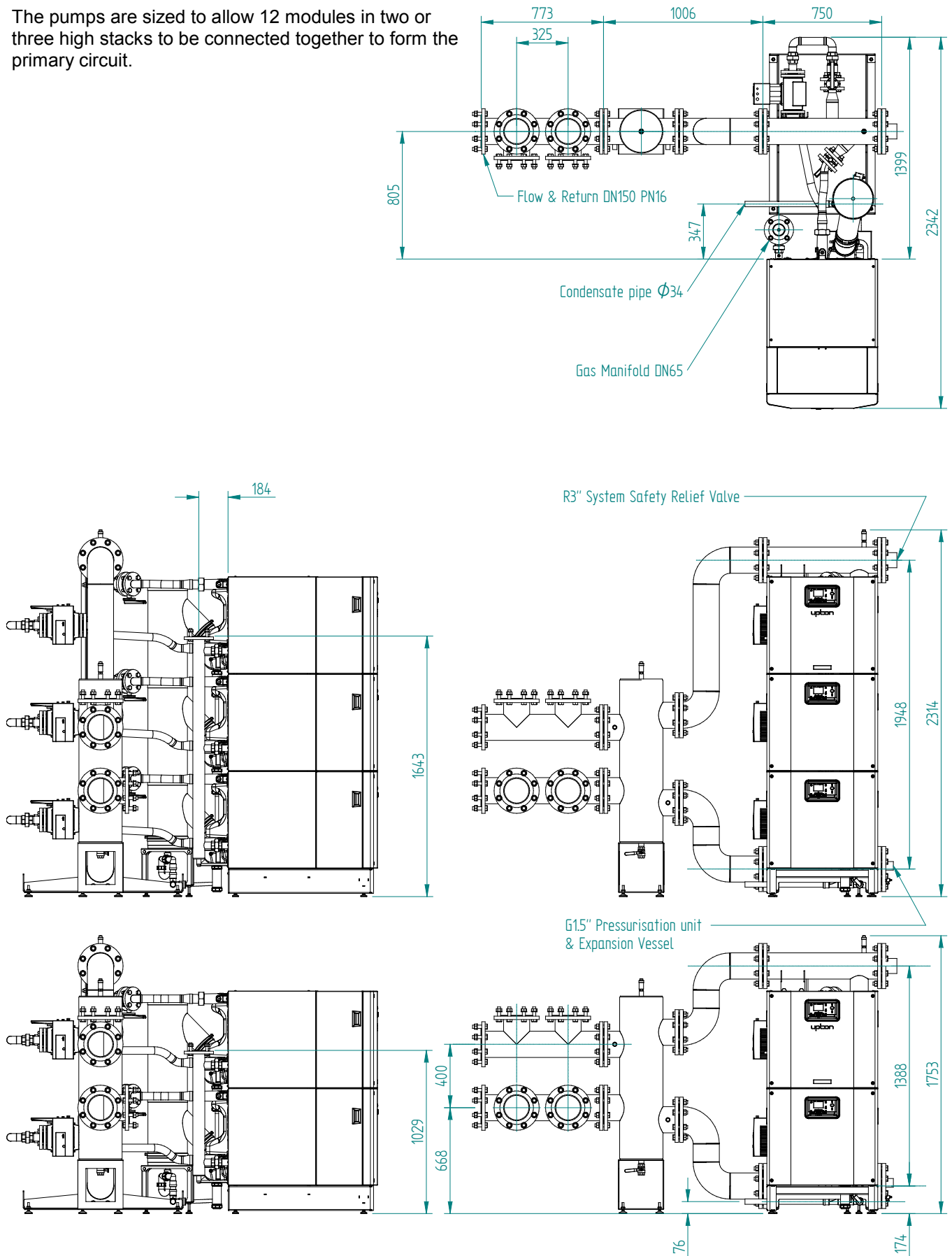

Figure 3.2.3 – UF200 & UF250 3MW Primary circuit and Gas manifold pipe kit

UF300 & UF350 DN150 2MW Primary circuit and Gas manifold pipe kit

The pumps are sized to allow 6 modules in two or three high stacks to be connected together to form the primary circuit.

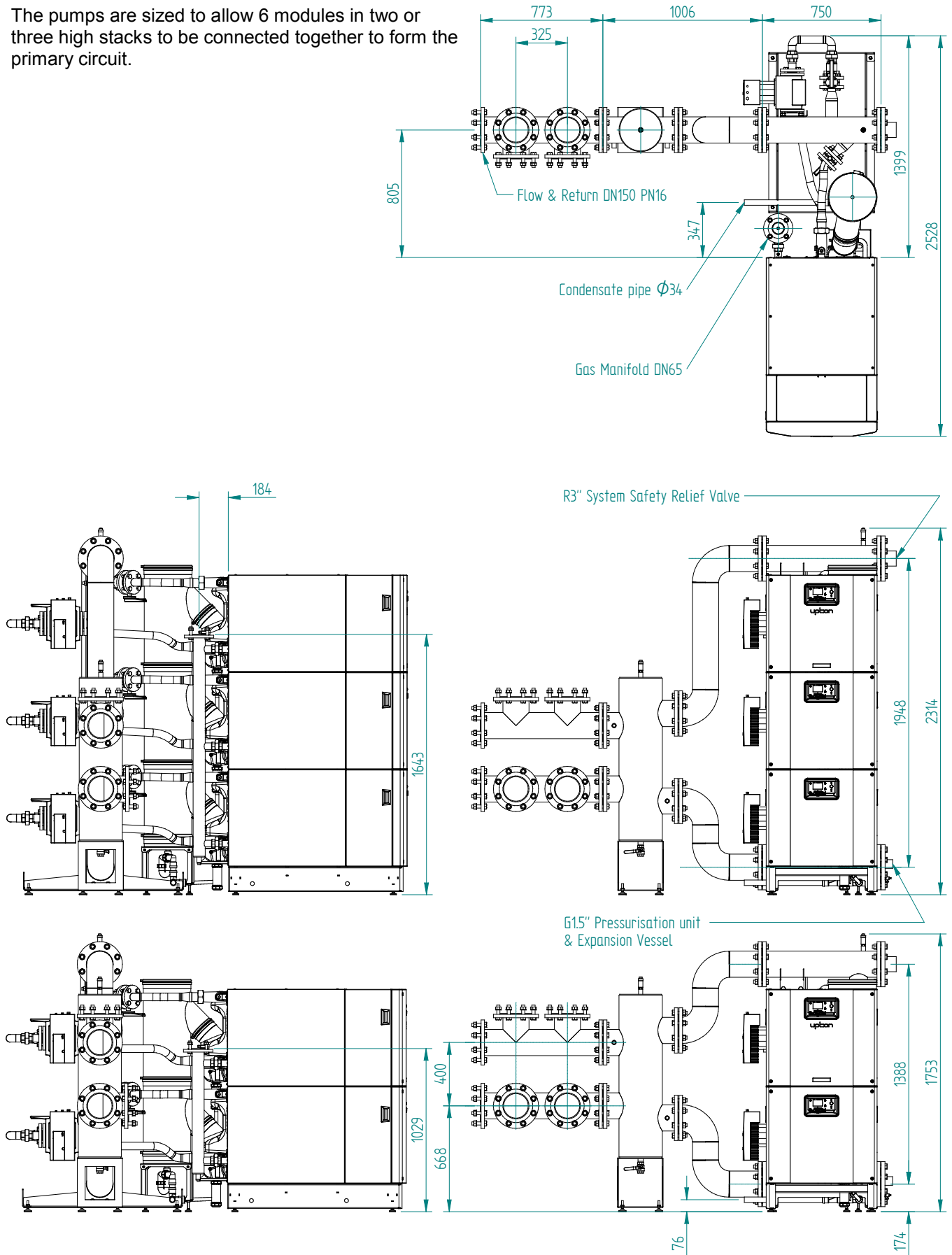

Figure 3.2.4 – UF300 & UF350 2MW Primary circuit and Gas manifold pipe kit

UF300 & UF350 DN200 4MW Primary circuit and Gas manifold pipe kit

The pumps are sized to allow 12 modules in two or three high stacks to be connected together to form the primary circuit.

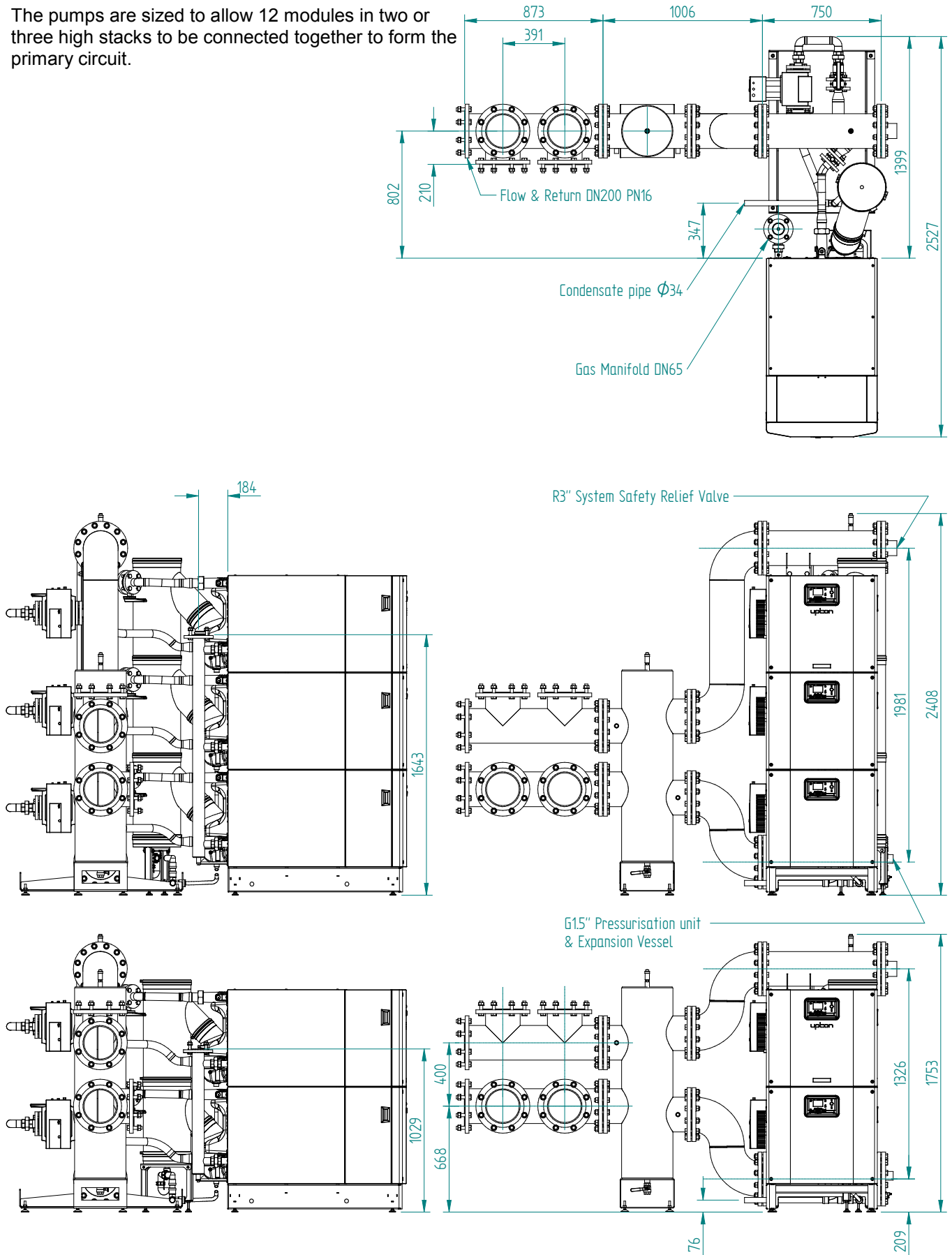

Figure 3.2.5 – UF300 & UF350 4MW Primary circuit and Gas manifold pipe kit

Figure 3.3 - Pipe Kit Data

Boiler Model		UF100/150		UF200/250		UF300/350		UF300/350	
Stack size		3 high	2 high	3 high	2 high	3 high	2 high	3 high	2 high
Number of modules		12		12		6		12	
Maximum output @ 20°C ΔT	MW	1.8		3.0		2.0		4.0	
Maximum pressure	bar	6							
Minimum pressure	bar	1.0		1.2		1.5		1.5	
Maximum flow rate	Kg/s	21.5		35.8		25.1		50.2	
Weights									
Flow and return manifold kit	kg	207	156	282	212	317	235	351	270
Low loss header and pipe work	kg	131	124	336	325	336	325	438	416
Secondary circuit manifold kit	kg	59		106		106		158	
Blanking flanges kit	kg	15		28		28		43	
Water content									
Flow and return manifold	l	36	27	65	50	65	50	87	73
Low loss header and pipe work	l	40	34	100	88	100	88	169	148

4.0 SITE LOCATION AND PREPARATION

4.1 Site Location.

- In the event that the boiler cannot be moved on a pallet truck, the four M8 bolts retaining the top cover can be replaced with M8 lifting eyes and using suitable lifting slings hoisted into position.
DO NOT LIFT THE BOILER BY THE CASING PANELS!
- The floor or plinth for the boilers and pipe work kit must be both flat and level to ensure correct alignment of fittings and connections.
- The floor or plinth must be sufficiently strong to support the weight of both the boilers and pipe work kit where used.
- The floor or plinth must be fireproof in accordance with BS 6644.
- The plant room must have sufficient space for installation of boilers, pipe work, pumps controls, flues ventilation, access and servicing and other items of plant.

Figure 4.2 - Gas Connection Point

M8 Lifting eye fixing positions.

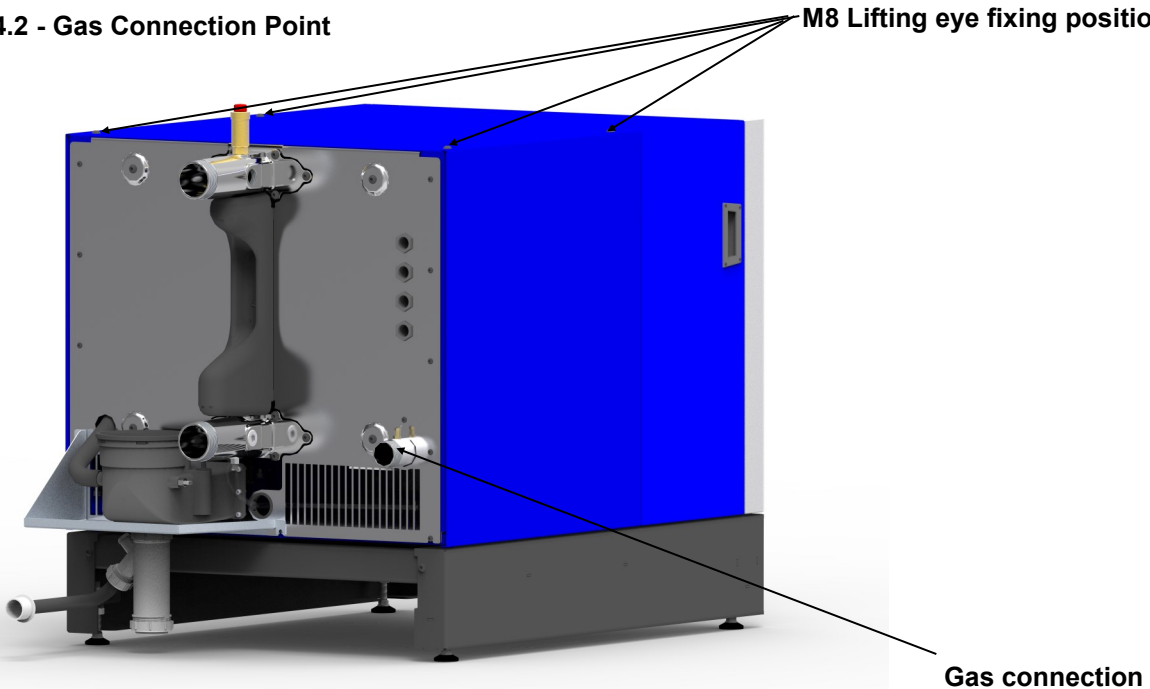

4.2 Gas Supply.

- Gas supply pipes must be in accordance with BS 6891 or IGE/UP/2
- Gas supply connections to the boiler must not be smaller than the connection on the boiler - R1¼" all models.
- Gas installation must be soundness tested to BS 6891 or IGE/UP/1 & IGE/UP/1A.
- Gas installation must be purged to BS 6891 or IGE/UP/1 & IGE/UP/1A.
- Boiler inlet gas pressure; nominal 20mbar (minimum 17.5mbar) for Natural Gas or nominal 37 mbar (minimum 25mbar) for LPG dynamic at the connection to the boiler.
- Boiler house gas isolation valve must be clearly identified and installed close to the entrance / exit.

4.3 Flue System

- Flue termination, routing and construction must comply with the requirements of the Clean Air Act 1993, BS 6644, BS 5440 and IGE/UP/10 where applicable.
- Upton boilers installed in modular format with a common flue, must use the manifold provided with the boiler prior to any connection to the flue system which must be suitable for condensing application.
- Upton boilers are suitable for open flue (type B_{23P}) installation, drawing combustion air from the plant room. The maximum number of modules firing into a common chimney is 8. The flue system must be designed to limit the max. suction to 100Pa (negative), measured at the flue sample point of the base module in the boiler stack. This condition must be checked hot and with all boilers firing, the max. pressure at the flue sample point should not exceed those stated in Appendix C Fig C1 - Flue data.
- Any stabiliser fitted must be in or close to the vertical chimney.
- Due to the low flue gas temperature, (~50°C) condensation will occur in the flue, flue materials must be non-corrosive and utilise fully sealing joints.
- Flue construction is recommended of a twin wall, insulated type to maintain buoyancy within the flue.
- Adequate facilities must be provided for draining the flue condensation.
- Horizontal flue runs must be kept as short as possible and be inclined at minimum 3° (50mm/m) towards the boiler. For maximum equivalent flue lengths, refer to Appendix C.
- Any flue must be self-supporting and separable from the boiler for servicing requirements.
- Note: Due to high thermal efficiency of the Upton boiler and the resultant low flue gas temperatures there will be visible pluming of the flue gases at the flue termination. This is likely even when the boiler is not operating at condensing temperatures.
- Fan dilution - the design must provide for the use of balancing and trim dampers, and their location and operation must be such that the constraints detailed above can be met. Care must be taken to ensure that the fan performance is matched to deliver the appropriate dilution, whilst ensuring that excessive suction is not applied to the boilers. If in doubt, refer to HHL Technical.
- Fan assist - the use of fan assist is not recommended as the boilers have sufficient fan performance to drive the system. If in doubt, refer to HHL Technical.

4.4 Water Supply

- The boiler must NOT be permanently connected to the water mains.
- The boiler must NOT be used for direct hot water supply. The hot water storage cylinder MUST be of the indirect type.
- Pressurised system to comply with BS 7074.
- The Upton boiler has an aluminium heat exchanger. It is a requirement that the system & pipe work are flushed at least twice before adding water treatment and before installing the boiler. The system water MUST be treated and maintained with an appropriate inhibitor (eg. Sentinel X100) and the PH MUST be managed between 7 & 8.5.
- In hard water areas (>180mg CaCO₃/litre) precautions such as water treatment are strongly recommended to prevent the build up of sludge and scale.
- Leaks in the system pipework should be fixed to prevent dilution of water treatment. To monitor the volume of make-up water entering the system, a water meter must be fitted and readings recorded in a log book to be retained on site. Do not top up with more than 5% of the installation's water content in any one year.
- Maximum working water pressure is 5.3bar.
- For minimum water pressure 0.5 bar - refer to Appendix E

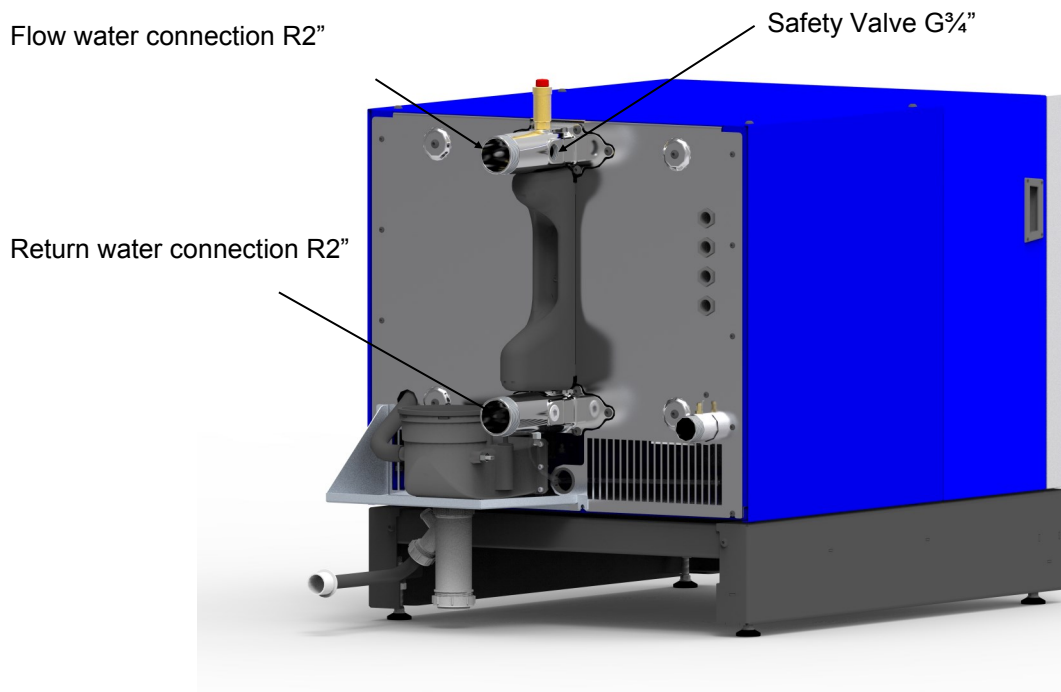

Figure 4.4 - Water Connection Points

4.5 Condensate Connections

- Provision must be made for removal of condensate from the boiler and flue system.
- If the flue system is longer than the standard length of 0.9m, an inline condensate drain must be fitted immediately before the connection of the flue system to the boiler and taken to drain.
- Condense is mildly acidic, typically pH3 - pH5.
- Condense pipe work must be non-corrosive and not copper. Hamworthy recommend Polypropylene plastic waste pipe.
- Condense may be discharged to a standard drain subject to National or Local regulations.
- Location of condensate pipe work should prevent freezing within tundishes, traps and pipe work.
- The connection to the boiler condensate drain accepts a straight push-fit coupling for 34mm o.d. (1¼") Polypropylene plastic waste pipe.
- Maximum condensate production - 15 l/h per 100kW firing capacity

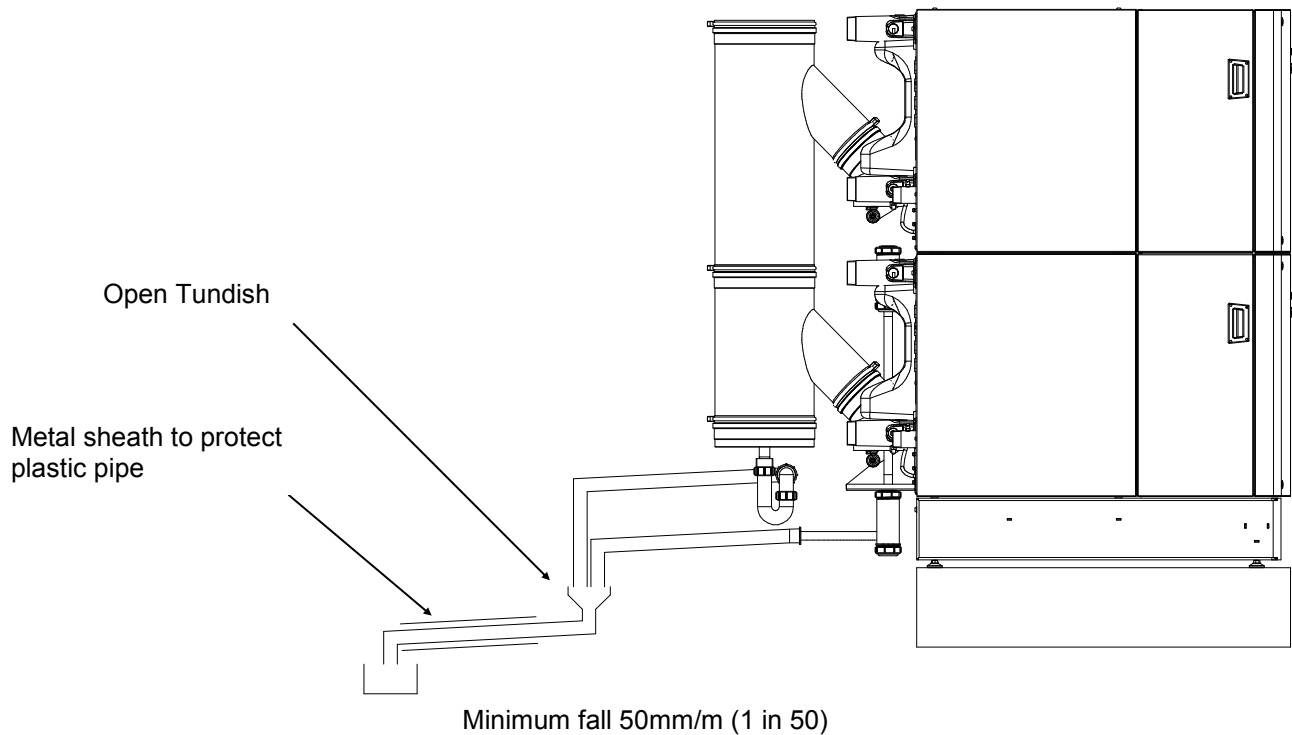

Figure 4.5.1 - Boiler Condensate Connection

4.6 Electrical Supply

WARNING! THIS APPLIANCE MUST BE EARTHED IN ACCORDANCE WITH IEE REGULATIONS

- Boiler electrical supplies must not be switched by a time clock.
- Boilers are suitable for 230Volt, 50Hz supply.
- External fuses should be rated for 10 amps
- Wiring must be completed in heat resistant cable size 1.0mm² csa.
- Each boiler MUST have individual means of isolation.
- Electrical isolators must facilitate complete electrical isolation.
- Electrical isolators must have contact separation of minimum 3mm in all poles.
- Electrical isolators must be installed in readily accessible locations.
- Electrical supplies to boiler modules should only serve the boiler using the conduits supplied. High & low voltage cables should be separated into individual conduits.
- Where an external alarm is required, terminals are provided which are volt free and rated at 230v.
- Time clock control should be via the boiler modules stop/start circuit (24V DC).
- Any interlock circuit must be in series with the time control for each circuit. The interlock circuit must never be used to isolate the boiler electrical supply.

ADDITIONAL INFORMATION REGARDING ELECTRICAL SUPPLIES IS GIVEN IN BS EN60335, Part 1.

NOTE: The appliance must be isolated from the electrical supply if electric arc welding is carried out on connecting pipe work.

FOR TYPICAL SCHEMATIC DETAILS SEE FIGURE 4.6

FOR DETAILED WIRING INSTRUCTIONS SEE FIGURES 9.3.1

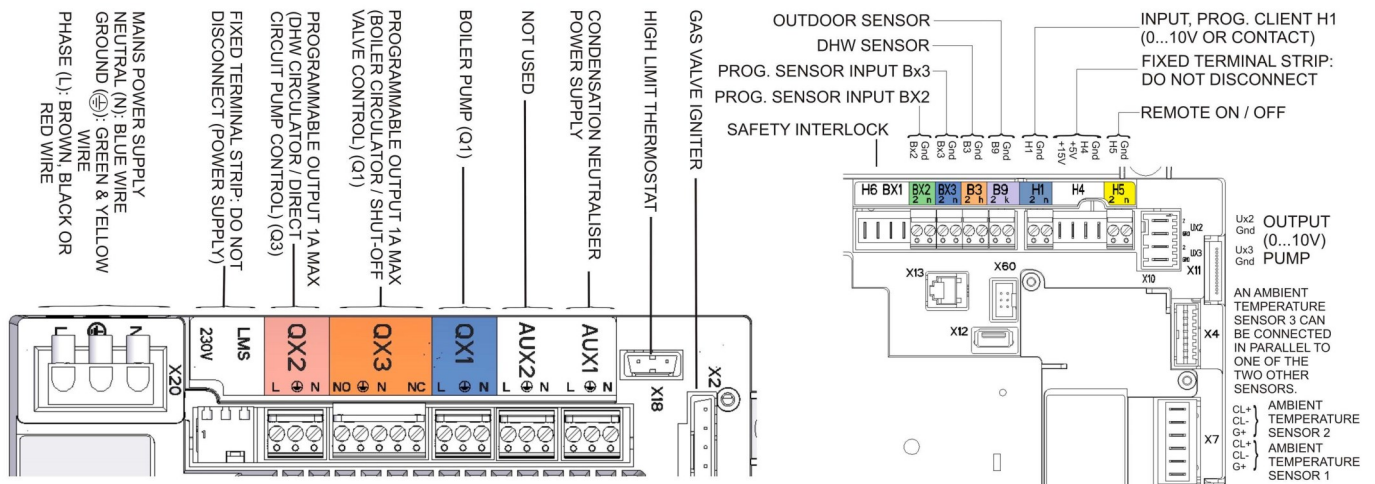

Figure 4.6 - Navistem Electrical Connections

5.0 BOILER ASSEMBLY

5.1 General

Boilers are despatched to site as fully assembled units. The flue components (where applicable) and pipe work kit (where applicable) are the only items that will need assembling on site.

During assembly it is important to take care to prevent damage to the boiler casing.

Boiler positioning must allow the minimum clearances detailed in Section 3.0 to facilitate access for flue and pipe work connections as well as maintenance. The boiler must be installed on a solid floor.

Health and safety. Due to the weight of the boiler and high centre of gravity on stacked modules, care must be taken when manoeuvring the boiler.

5.2 Water Connections

The connections provided on the boiler (refer to Appendix E and figure 4.4) are suitable for direct connection to the system pipe work. However HHL recommend the use of individual isolating valves, which should be fitted to each module to enable isolation from the system. However, the arrangement must comply with the requirements of **BS 6644**.

When installing water system pipe work, it must be self supporting and care must be taken to ensure that undue stress is avoided on the boiler flow and return connections. It is recommended that unions are fitted local to the boiler and outside of the casing, to permit future servicing requirements.

The Upton is designed to operate at 20°C ΔT across the flow and return. Should the flow rate drop, the boiler controls will modulate the burner to maintain 20°C ΔT . As a safety precaution, a flow switch is fitted to the boiler heat exchanger to shut the system down in the event of sudden adverse flow conditions.

Where using Hamworthy Heating Ltd pipe work kits, assembly of these is detailed in Instruction Manual supplied with kit.

5.3 Flue Connection

The Hamworthy Upton boiler is designed for use with open flue systems type B23p - Intake from ventilated plant room and discharge via horizontal/vertical flue.

1. With the boiler in its desired location, engage the flue collector ducts into each other and position such that the spigots will fit into the respective flue sockets at the rear of the boiler. In assembling the flue ducts, it is advisable to lubricate the seal located in the socket fittings using a Silicon based lubricant, to enable easy movement and adjustment.
2. Fit and secure the bottom closing plate to the base of the duct assembly. Use the adjustable frame provided to support the weight of the flue system.

Note: Should modules be arranged in banks of 2 or 3 high, adjacent to each other, it is advisable to fit the water and flue connections to each individual bank prior to fitting the connections to the adjacent bank(s).

Flue systems should be designed with reference to BS 6644, IGE/UP/10 and Third Edition of the 1993 Clean Air Act Memorandum.

Connecting flue pipework must be self-supporting to avoid stress on the boiler connections. Local unions are recommended in the flue pipework to facilitate future servicing requirements.

5.4 Sealed Systems

Boilers must not be capable of isolation from the safety valve. Valves between boiler and safety valve to be three way type such that when boiler is isolated from the safety valve it is open to atmosphere. Hamworthy Heating Ltd recommend using the safety valve connection provided on the boiler.

Where using Hamworthy Heating Ltd pipework kits, assembly of these is detailed in Operation and Maintenance manual supplied with kit.

5.5 Electrical Connections:

The following electrical connections are provided on each module.

- Supply: Live, Neutral and Earth. See Section 4.5 for details.
- Optional Boiler Fault Alarm & Normal Run Signal Output (optional AGU clip-in kit)
- 0-10v Analogue Control Signal Input
- Remote on/off Control Input
- Boiler Pump Output, DHW pump output, motorised valve output
- Safety Interlock Circuit Input
- Optional LPB Bus for use with Merley cascade control (optional OCI clip-in kit) & Master/Slave sequencing

6.0 PRE-COMMISSIONING

The following pre-commissioning check must be carried out before the boiler is commissioned.

6.1 Gas Supply.

Ensure that gas installation pipe work and meter has been soundness tested and purged to IGE/UP/1 or IGE/UP/1A as appropriate. Test and purge certificates should be available for viewing.

6.2 Ventilation

Ensure that ventilation and air supply to plant room is correct.

6.3 Pipe work, Valves and Pump

Ensure that;

- System flushing and suitable water treatment has been implemented
- Pipe work and valve arrangement is installed to Hamworthy Heating recommendations.
- Circulating system is full of water, vented and pressurised appropriately and the water quality checked.
- Circulation pump is fitted, working and interlocked where required.
- Pipe work connections to boiler are fitted correctly.
- Safety valve is correctly sized and located.
- All necessary isolation valves are open.
- Condense connections on boiler and flue are connected and piped to drain.
- Heat load is available.

6.4 Flue

Ensure that;

- Flue system is correctly designed and installed to suit boilers.
- Flue passages to chimney are clear.

6.5 Electrical

Ensure that;

- Electrical connections are correct and isolatable.
- External controls are operational.

WARNING: WHEN THE FRONT COVER IS REMOVED AND THE BOILER IS OPERATIONAL, CARE MUST BE TAKEN WITH ELECTRICAL COMPONENTS AND ACCESS TO PRIMARY INSULATION.

7.0 CHECKS PRIOR TO LIGHTING

IMPORTANT: BEFORE PROCEEDING ENSURE THAT THE PRE-COMMISSIONING CHECKS ON PAGE 14 HAVE BEEN CARRIED OUT AND THE RESULTS SATISFACTORY.

7.1 Boiler Gas System Leak Check

Ensure that the appliance manual gas service valve is in the **OFF** position. Although the boiler receives a gas leak check and gas train component integrity check prior to leaving the factory, transport and installation may have caused disturbance to unions, fittings and gas valve assemblies etc.

A procedure guide is given below. Care must be taken not to allow leak detection fluid (if used) on or near any electrical parts or connections.

NOTE: The test detailed below must be carried out on each module.

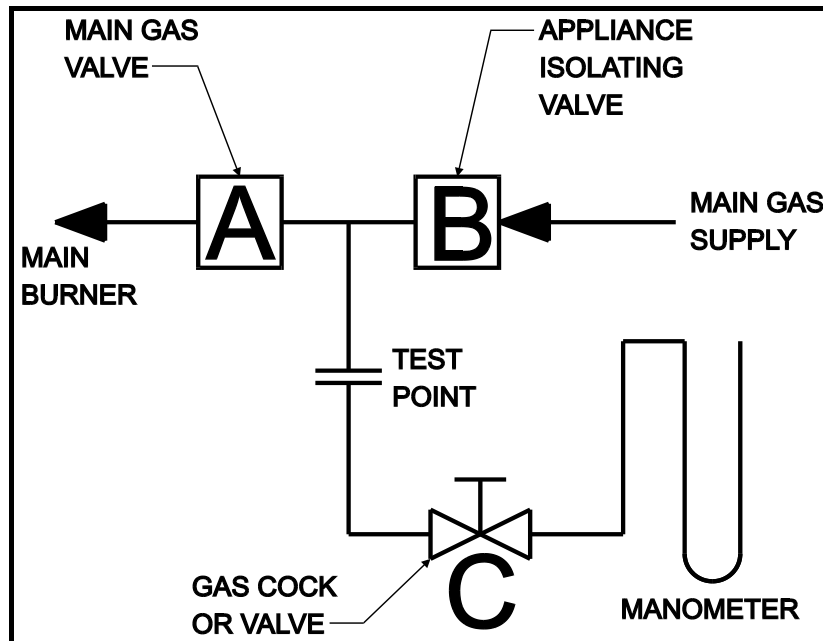

Figure 7.1 - Gas System Leak Check Diagram

Note:-

Main Gas Supply Pressures are as follows;
Natural Gas - 20mbar
LPG - 37mbar.

TO CHECK B

- 1) Turn off the electrical power and gas supply to the appliance.
- 2) Connect the manometer assembly to test point (Fitted on the inlet to the gas valve).
- 3) With A and B closed open C and monitor manometer over a 2 minute period, a rise indicates a leak on valve B.

TO CHECK A

- 1) Open C.
- 2) Open B to produce the mains gas supply pressure between A and B.
- 3) Close B.
- 4) System may be considered sound if over a period of 2 minutes any drop in pressure is less than 0.5 mbar (0.2" wg.).

Note:- Allow a manometer stabilisation period of approximately 1 minute before each 2 minute check period. Following soundness tests close valve B and remove manometer connections and tighten test points.

7.2 Checks prior to lighting the boiler

Note: Refer to Appendix A, Gas Data Tables, for maximum inlet pressure for normal operation.

7.2.1 The Following checks must be made prior to lighting the boiler;

1. Open the front cover to gain access to the boiler components. The cover is secured with four socket head screws, requiring an Allen Key. Carefully lift off the cover to expose the boiler components and installer wiring connections.

Note: Before starting the boiler commissioning procedure verify the following;

2. Ensure that all external controls are not demanding that the boiler commences operation.
3. Ensure that the gas supply is connected, but the boiler module gas service valve(s) are **closed**, any unions or fittings are correctly tightened and test points are **closed**.
4. Check that the heating system has been flushed and refilled and that air has been purged from all high points.
5. Ensure that the system isolating valves are in the open position and that the water pressure within the heating system is correct. Minimum pressure 0.5barg.
6. Ensure that the flue ducts are correctly fitted and that they are free from obstruction. Check that the outlet terminal is located correctly and in accordance with regulations.
7. Ensure that the gas supply has been properly purged and verified for gas soundness. A purge and soundness certificate should be available from the gas pipe work installation contractor.
8. Turn on the mains gas supply. Check that sufficient gas pressure is available at the boiler, nominal 20mbar (minimum 17.5mbar) Natural Gas or nominal 37mbar (minimum 25mbar) LPG.
10. Ensure that all electrical connections made to the boiler are correctly sized and installed. Refer to wiring diagram in Figure 9.3.1
11. Check that the boiler controls wiring has not been modified. Any modification could lead to boiler failure.

7.2.2 Gas inlet pressure test

The gas pressure must be checked at the inlet to the boiler. This is to ensure that the gas pressure is both constant and sufficient to provide full burner output. To verify this the pressure has to be taken as a static and a dynamic reading. The dynamic reading cannot be taken until the boiler has been started - refer to 8.4

The gas inlet pressure test point is at the rear of the appliance adjacent to the inlet gas connection.

7.3 Commissioning the Boiler

Once the preliminary checks have been completed and the gas inlet pressure has been verified as correct, commissioning of the boiler modules may begin.

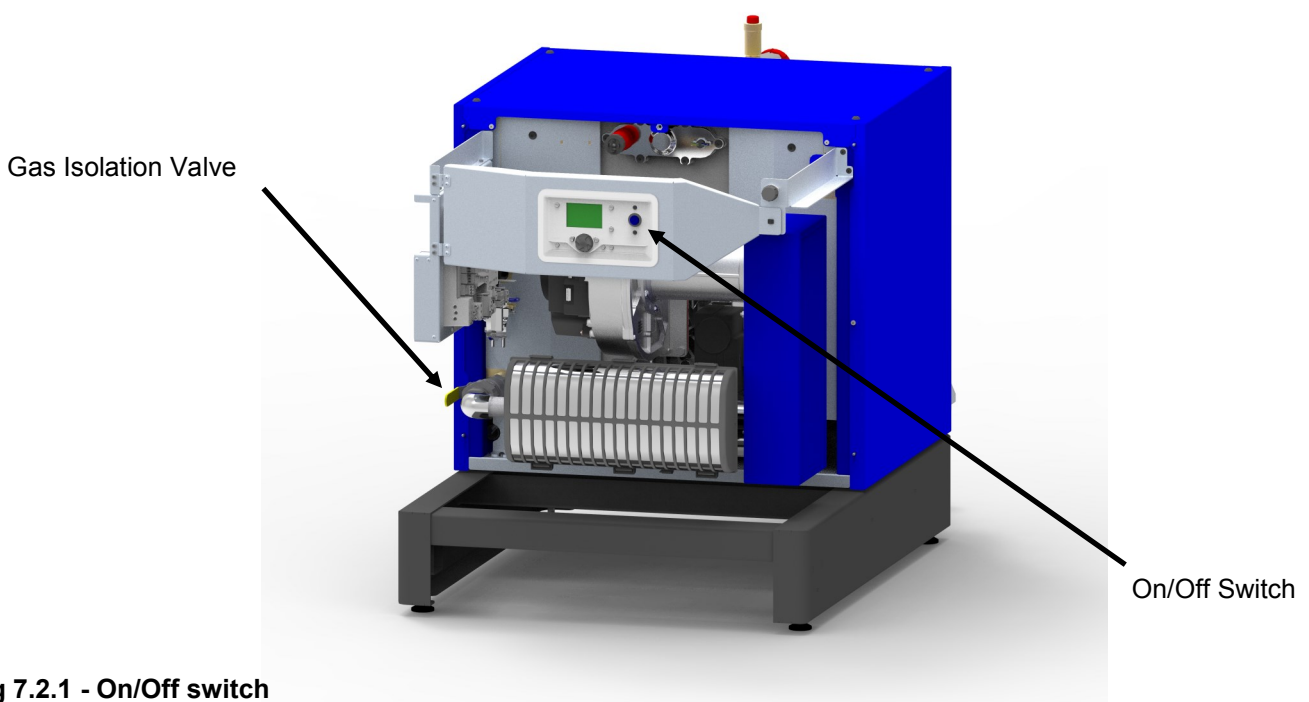

Fig 7.2.1 - On/Off switch

8.0 Initial Lighting

Only competent persons registered for working on non-domestic gas appliances should attempt the following operations. Before attempting to commission any boiler, ensure that personnel involved are aware of what action is about to be taken.

Record all readings for future reference on relevant commissioning sheet.

Allow system to warm up sufficiently to check operation of control thermostat.

A combustion check must be taken when first commissioning the boiler. A sampling point is provided in the boiler - refer to **section 8.5 - Combustion Checks**

8.1 Operational Checks

NOTE! Care should be exercised when the boiler is firing, as the heat exchanger components can achieve temperatures which could cause injury if touched.

1. Ensure that all external controls are in demand and that the gas supply to the module is isolated. Check and adjust if necessary the low gas inlet pressure switch located on the side of the boiler gas valve (fig. A2– Gas data)
2. Switch the on/off switch located on the front panel of the boiler to the on position, and initiate the start up sequence. Refer to separate Navistem manual, HHL part no. 500001310).
3. As the gas valve is closed, the low gas pressure switch will prevent the boiler from firing and the error code 'E132' will be displayed on the screen. Refer to separate Navistem manual, HHL part no. 500001310.
4. If the above procedure occurs correctly, open the gas isolating valve and the fault indication will extinguish. The boiler will commence its ignition sequence as previously described. This time, when the gas valve is energised the burner will ignite.
5. With the burner firing, the flame signal displayed, should be approximately 6-11µA. Refer to separate Navistem manual, HHL part no. 500001310.
 - At the end of the ignition proving period, 5 seconds, the spark ignition system will be switched off and the flame indicator on the control fascia is lit.
 - After a period of 10 seconds the fan will alter speed and the burner modulation will be set according to the heat load.
 - If after the 5 second flame proving period the flame signal is below the minimum detection current, the boiler will shut down and attempt one restart.

NOTE: THE BOILER IS EQUIPPED WITH A RESTART FACILITY AND WILL ATTEMPT A SECOND IGNITION, DURING WHICH THE ABOVE PROCEDURES WILL BE REPEATED. AT THE END OF THE RESTART PROCEDURE, IF NO FLAME IS DETECTED AFTER THE FLAME PROVING PERIOD, THE BOILER WILL LOCK-OUT. THE BOILER WILL NOT OPERATE UNTIL THE LOCKOUT HAS BEEN MANUALLY RESET.

8.2 Controls Operation

Each Upton boiler is controlled by a Navistem boiler controller.

The controller functions, settings and configurations are accessed via the rotary dial on the individual fascia panels (fig. 8.2.1)

Comprehensive details and instructions on setting and using the boiler controller can be found in the separate **Navistem** instruction manual, HHL part no. 500001310, which is supplied with each boiler.

A concise user instructions guide (HHL part no. 500001309) is supplied with each boiler. This guide gives instruction on initial set up as well as a list of possible error codes.

The Navistem controller is located on the main control panel assembly which can be accessed after removal of the boiler front cover (fig.8.2.2).

Note: Should remedial work be carried out on a module, then the non-firing module must be electrically isolated so as to prevent accidental operation in the event that the installation is required for ongoing heating requirements.

Figure 8.3.1 - Operating phases

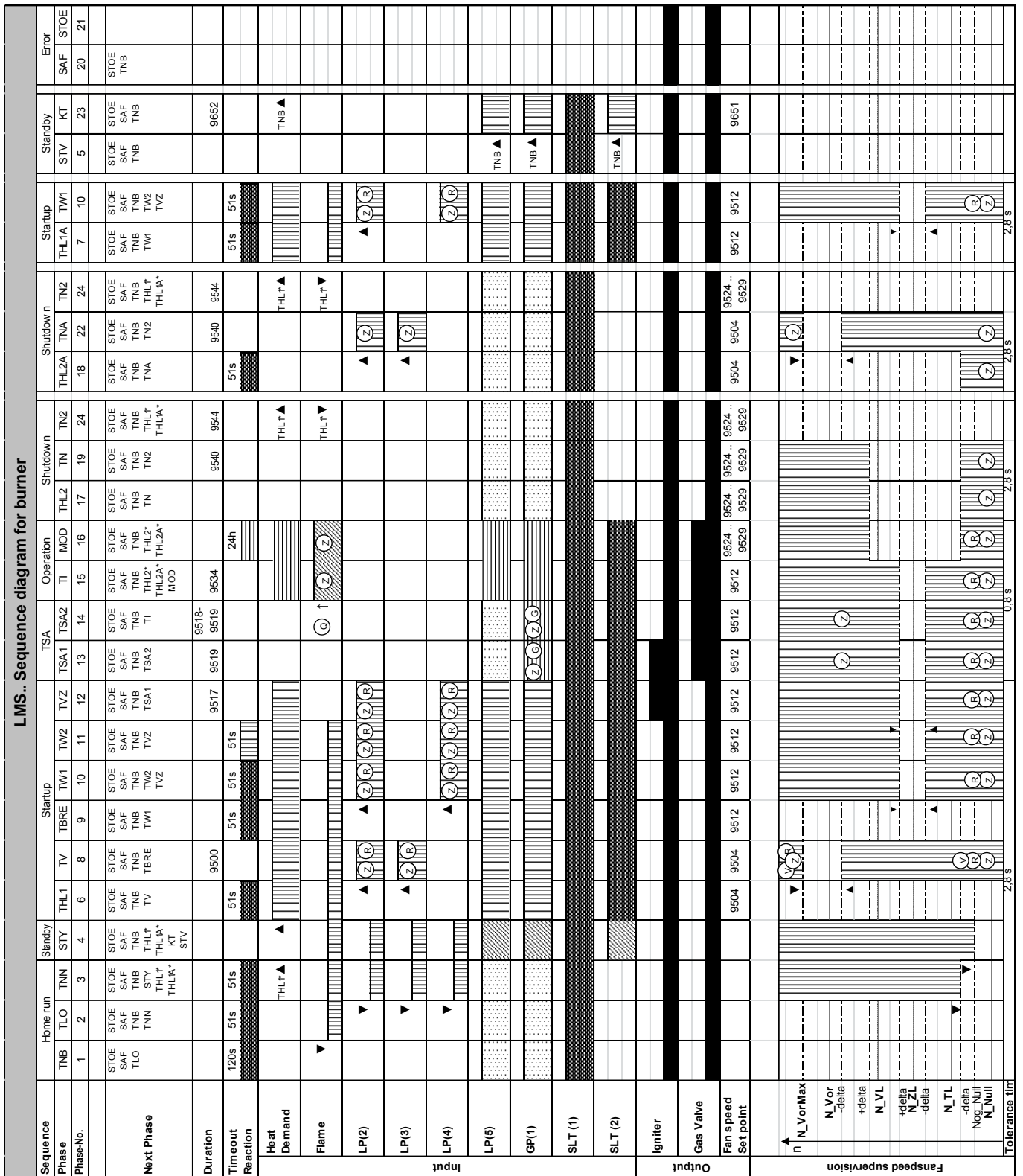

8.3 Ignition Controller Check.

1. With the burner firing, the flame signal should be at least 3 μ A. Refer to **separate Navistem manual**, HHL part no. 500001310. To check for correct operation of the ignition controller, close the gas valve. The boiler should shutdown after approximately one second and attempt a re-ignition. Check that the flame has been extinguished
2. Alternatively, the flame probe lead can be removed from the end of the flame probe, with the same result.

8.4 Gas Supply Pressure Check.

1. When the boiler modules have been checked for correct operation the gas supply pressure should be checked. This should be done with all modules firing.
- For Natural Gas, a nominal gas inlet pressure of 20mbar measured at the rear of the boiler is required, with a maximum inlet pressure of 25mbar.
 - For LPG, a nominal gas inlet pressure of 37mbar measured at the rear of the boiler is required, with a maximum inlet pressure of 45mbar.

8.5 Combustion Checks

“The boiler modules are factory pre-set, but site checks must be done to confirm correct performance.”

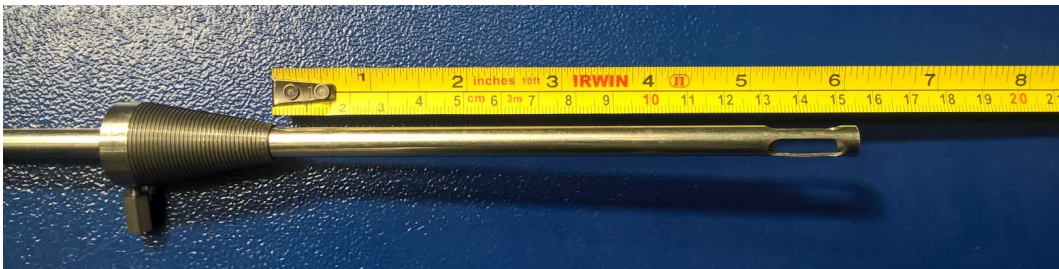

Figure 8.5.1 - Combustion Analyser Probe Setting

1. Remove the flue gas sampling plug from the flue gas sample pipe, accessible from the front of the boiler and insert the combustion analyser probe.
2. Ensure that an insertion distance of 155mm is set on the combustion analyser probe.

NOTE: THIS DISTANCE MUST BE SET TO ENSURE ACCURATE ANALYSIS OF FLUE GASES.

3. Insert probe horizontally into the flue gas sample pipe until depth stop is met.

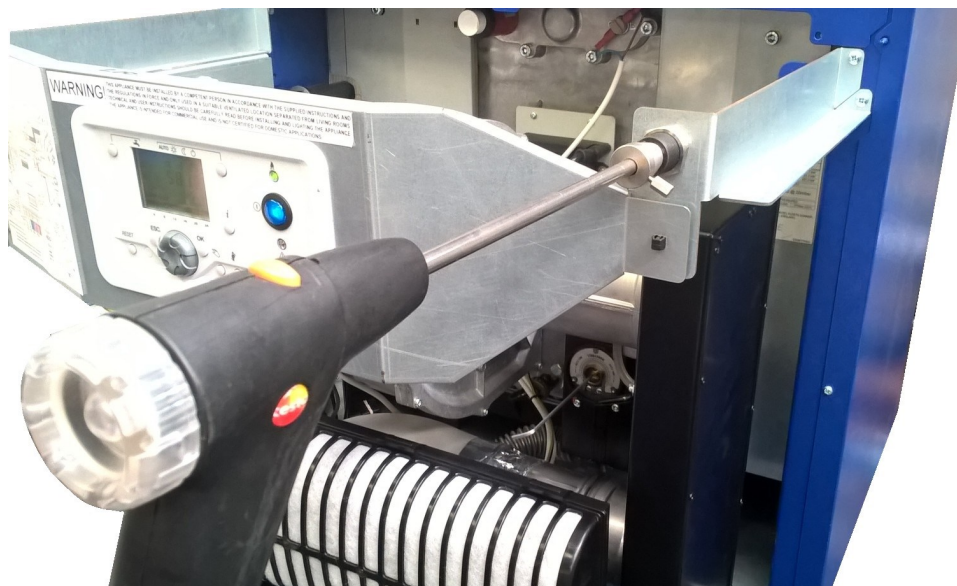

Figure 8.5.2 - Insertion of Analyser Probe

4. If combustion is outside of the ranges defined below the factory sealed valves may be adjusted using the following procedure .

Models - UF100 –UF150

High Fire Target **Nat Gas - 9.0% ±0.2% CO₂**
LPG - 10.55% ±0.2% CO₂

If combustion level is outside of this range use the Throttle Screw to adjust the mixture.

THIS SETTING MUST BE CORRECT BEFORE CONTINUING
To increase the CO₂ level, turn the adjustment anti-clockwise.

Figure 8.6.4 - Adjusting gas valve throttle

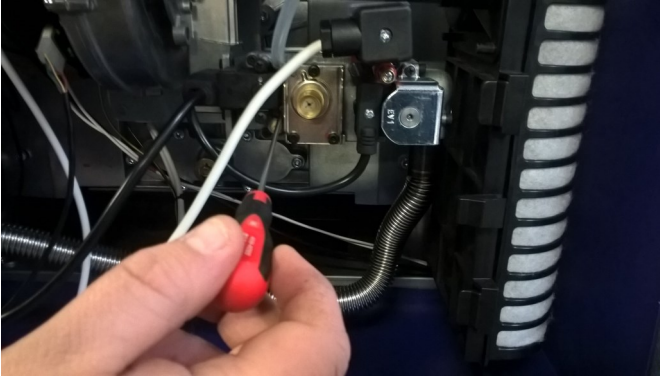

Models - UF200– UF350

High Fire Target **Nat Gas - 9.0% ±0.2% CO₂**
LPG - 10.55% ±0.2% CO₂

If combustion level is outside of this range use the Throttle Screw to adjust the mixture.

THIS SETTING MUST BE CORRECT BEFORE CONTINUING
To increase the CO₂ level, turn the adjustment anti-clockwise.

Figure 8.6.4 - Adjusting gas valve throttle



Models - UF100 –UF150

Low Fire Target **Nat Gas 8.4% ±0.1% CO₂**
LPG - 9.97% ±0.1% CO₂

If combustion readings are outside target range use a screwdriver to make adjustments

To increase the CO₂ level, turn the adjustment clockwise.

Figure 8.6.5—Adjusting gas valve offset

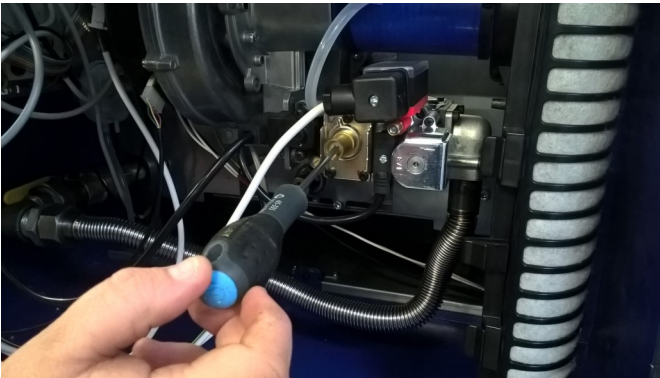

Models - UF200– UF350

Low Fire Target **Nat Gas 8.4% ±0.1% CO₂**
LPG - 9.97% ±0.1% CO₂

If combustion readings are outside target range use a screwdriver to make adjustments

To increase the CO₂ level, turn the adjustment clockwise.

Figure 8.6.5—Adjusting gas valve offset

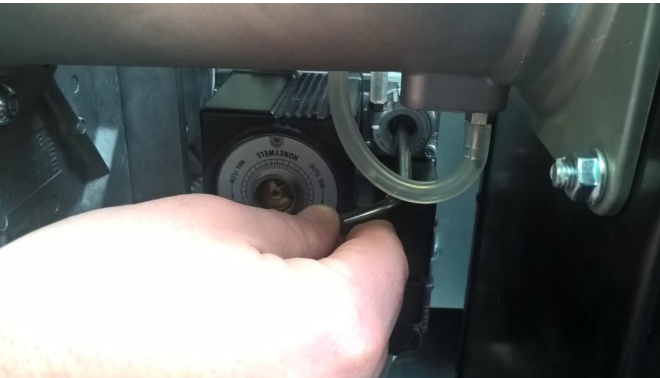

Fig 8.5.3 - Combustion settings

(**Note:** readings taken with front cover removed and 155mm probe insertion CO = < 80 ppm*).

5. Energise electrical supply and start the boiler module. The burner will ignite and run at 100% modulation.
6. Monitor the combustion readings on the combustion analyser at both Maximum and Minimum firing rates - refer to section 8.2.8.2 - Controller Stop function

***Figure must not exceed 80ppm under normal operating conditions.**

If combustion readings fall within the required range the boiler module is set and operating correctly. If the combustion readings fall outside the required range the burner settings will require adjustment.

CONTACT HAMWORTHY HEATING TECHNICAL DEPARTMENT FOR FURTHER DETAILS

7. Shut down the boiler and isolate from the electrical supply. Remove instrumentation and replace test points and plugs.
8. Refer to **section 8.1 - Controls Operation**, to adjust the relevant boiler settings specific to the installation

8.6 User Instructions.

When the boiler is fully commissioned, the owner or their representative should be made aware of the lighting-up and operating instructions. A practical demonstration should be given describing each functional step. This Installation and Commissioning guide, the servicing instructions manual and the user's instructions should then be handed over and be kept in a safe place for future reference.

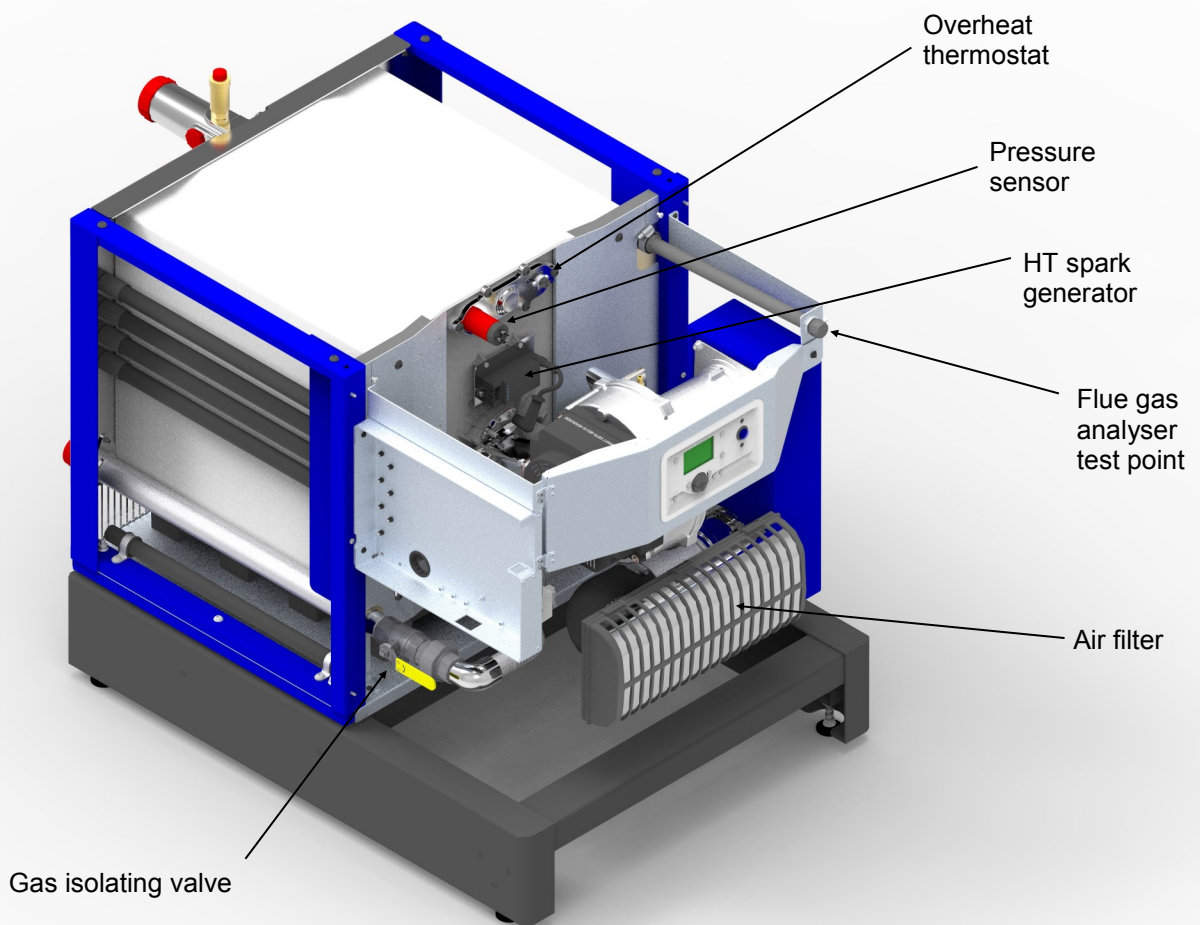
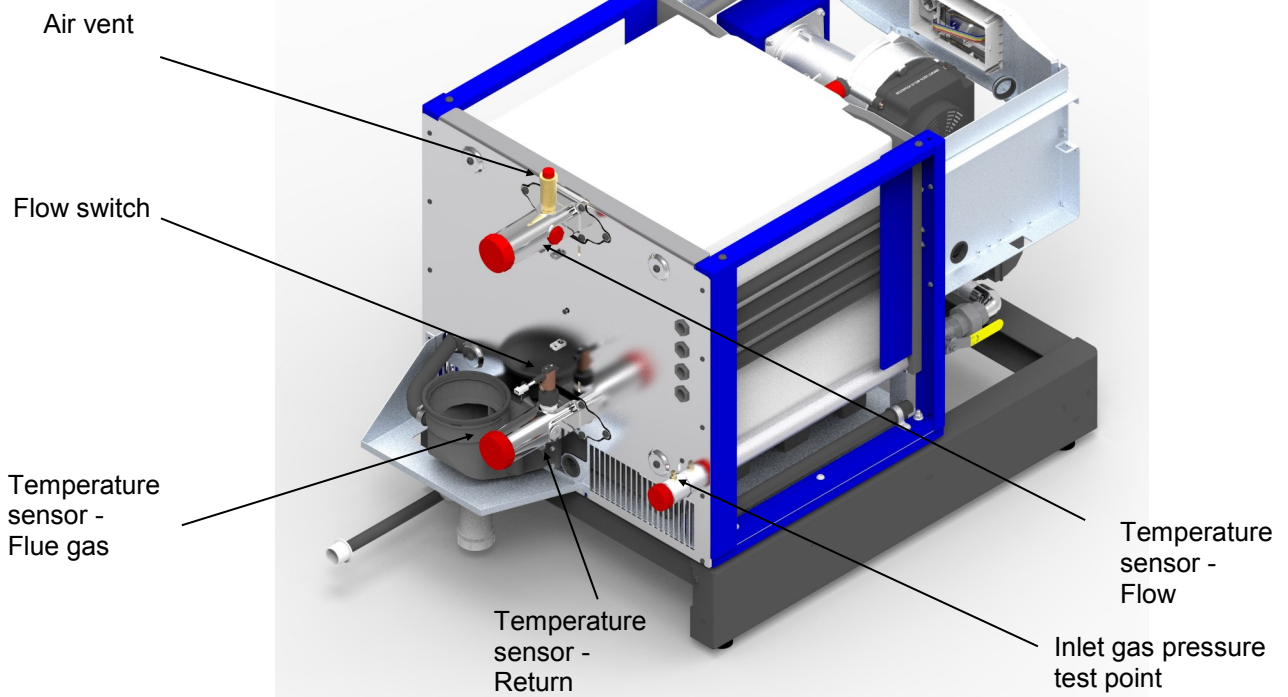

Figure 8.5.4 - General Overview of Boiler Controls

9.0 FAULT FINDING

The Upton boiler is equipped with full self-diagnostic fault indication, with faults being allocated a code. A lockout will be denoted by a flashing LED on the fascia panel which will also be constantly illuminated by a block error - refer to **the separate Navistem manual**.

The common fault codes are detailed in **the separate user instructions guide**. Fault codes not detailed in this manual should only be investigated by an Engineer.

Should a fault code appear which cannot be reset, or a fault code repeatedly occurs, contact Hamworthy Heating for assistance. Do not continue to operate or use the boiler

9.1 Safety Temperature Limiter (Limit Thermostat)

1. The electronic control thermostat has several safety levels built in such that a controlled shutdown should occur before the safety temperature limiter is activated. Should these safety levels be overridden (say external pump overrun failure after shutdown) the safety temperature limiter will trip initiating a boiler shutdown, preventing the boiler from firing. A code on the controls display will flash indicating that the safety temperature limiter has tripped.
2. The limit thermostat (mounted on the front of the heat exchanger assembly - visible after removing the front cover) will automatically reset after the boiler returns to a normal operating temperature.
3. Always carry out an investigation to ascertain the reason for overheating. The most common cause of overheating is lack of water flow rate through the boiler - possibly due to external pump problem.

9.2 Ignition Controller

1. The flame is under constant supervision by the burner ignition controller. The controller monitors the flame's ability to rectify an AC current. If the flame diminishes for whatever reason and the rectified current drops below the controller's minimum detection current, the controller will de-energise the gas control valve within 1 second and commence a restart. Failure to establish and detect a flame during the light-up sequence will result in burner shutdown and lockout within 5 seconds, requiring a manual reset to restart the ignition sequence.
2. If the boiler continues to lockout, then an investigation must be made to ascertain the cause.
3. A false flame signal at the start and during pre-purge will cause the boiler module to restart its ignition sequence at the end of the pre-purge period. If this occurs 3 times in succession the controls will disable operation of the boiler module, requiring reset of the module.

9.3 Water Flow Switch

1. The water flow switch is located on the return pipe (see Figure 8.5.4) and will prevent the boiler from firing should there be inadequate or no water flow. This is to protect the heat exchanger from damage in the absence of water (dry firing) which will cause catastrophic failure of the heat exchanger.
2. The operation of the flow switch can be checked by closing one of the isolating valves connecting the boiler to the system, this will generate error E164 on the HMI display.

Figure 9.3.1- Wiring Diagram

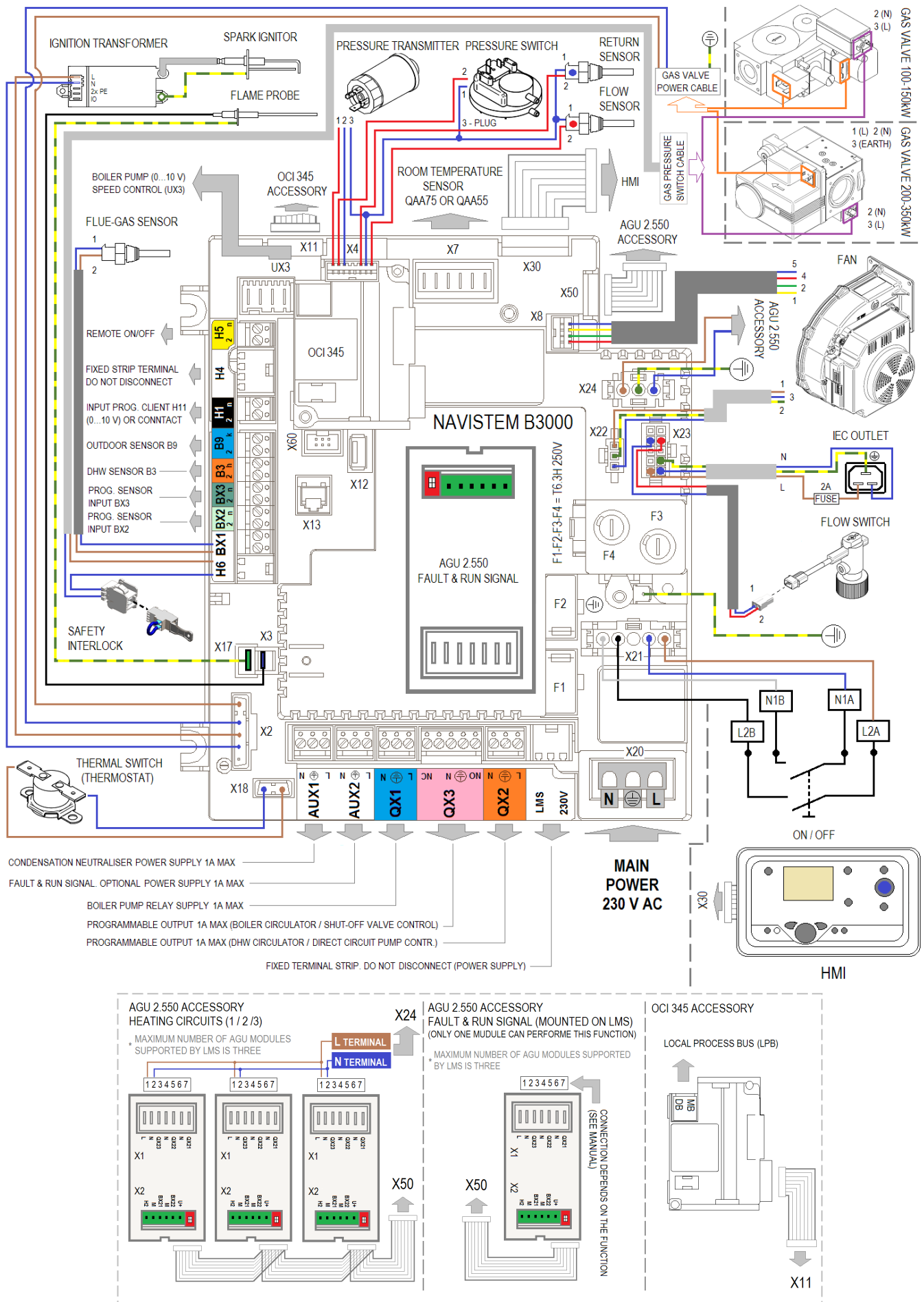

10 SERVICING

A Gas Safe Engineer registered for working on non domestic gas appliances should check and ensure that the flue, its support and terminal, the ventilation to the boiler house, safety valve, drain, water filter if fitted, pressure gauge, etc.; are in a serviceable and working condition and still comply with the relevant standards and codes of practice - see **Section 4**.

10.1 Regular servicing is recommended, preferably by a Hamworthy appointed person, and at least annually, to ensure trouble free operation.

For Upton boilers, Hamworthy would recommend an additional 6 monthly examination following commissioning, acknowledging site conditions and running hours.

Although cleaning of flueways may not be necessary on a yearly basis, it is important that all controls and safety features are checked for correct operation.

Note:- Measuring flue gas CO₂ and gas temperatures will give an indication of the state of the boiler flueways and waterways. Results should be compared with previously measured values to establish possible loss of efficiency.

10.2 Annual Service

Before servicing the boiler, the following procedure must be carried out :-

WARNING: Isolate all electrical supplies and turn off the gas service valve.

1) Remove the front cover. Once removed access is gained to the controls panel, the heat exchanger components and the combustion system assembly.

2) Carefully disengage the air filter from the venturi and remove the electrical plugs from the gas valve.

3) Disconnect the fan power supply and control leads from the fan taking care with the latch on each connector.

4) Disconnect the H.T and flame probe connectors from the respective probes.

5) Check that the gas service valve is closed, then undo the flange on the inlet to the gas valve.

6) Remove the 3 M8 socket head screws securing the fan /burner duct assembly to the heat exchanger and carefully remove the assembly.

7) Remove and inspect H.T. electrode and flame probe, ensure they are free from debris or deposits. – See Figures 10.2.1 & 10.2.2

8) Remove the burner from the burner duct, check and clean using a soft brush if required (if possible use a vacuum cleaner to remove the dust from inside the burner tube). After cleaning the inside, the burner tube can be washed using a soapy water solution. Tap the burner flange firmly downwards on a block of wood to dislodge any residual debris from inside the burner tube. A damaged or cracked burner should be replaced.

Note:- Do not use a wire brush to clean the burner.

9) Separate the gas valve / gas valve manifold / venturi from the fan inlet noting it's orientation and inspect the fan scroll and impellor, clean and check for damage.

10) Clean and check the venturi for contamination.

11) Remove the fan from the burner duct and inspect the non return valve in the duct for smooth operation.

12) Check that the mesh inlet filter in the gas valve is clear of debris, remove any foreign objects caught in the filter.

13) Check and clean air filter. Filter can be washed in clean water.

Re-assemble in reverse order taking care to inspect and if necessary, replace any o-rings, gaskets or seals.

Refer to **Section 8, Commissioning and Testing**, and test all gas joints broken or disturbed for soundness before firing.

Carry out a combustion check by testing the flue gas CO₂ and CO levels as detailed in **Section 8.2**.

10.3 Four Year Service

Repeat the annual service as previously described but do not refit any components to the heat exchanger.

Isolate the boiler flow and return connections from the heating system.

10.3.1 To clean the heat exchanger, the use of a high pressure water hose (40-80 psi) is recommended for the primary flue gas path. However provision must be made for the drainage of water used in this process. At the rear of the boiler remove the condensate drain trap assembly from the flue elbow. Connect a hose (32mm id.) to the flue elbow and take to a suitable drain or receptacle. The cleaning water and any debris will exit the sump through this opening.

To clean the condensing flue gas path, isolate the boiler from the heating system and drain the boiler heat exchanger using the drain valve provided in the front of the heat exchanger. Disconnect the electrical supply to the flow and return sensors, flow switch, spark generator, pressure transducer and limit thermostat. Disconnect the flexible gas pipe union and the insulation plates bolted to the front of the heat exchanger.

Remove the 6 M8 screws securing the flow and return pipes on the back of the heat exchanger.

Remove the 4 M8 screws securing the heat exchanger assembly to the chassis back plate.

Remove the 6 M6 screws securing the flue elbow to the sump. The heat exchanger can now be removed from the casing. With the heat exchanger removed from the appliance, remove the plastic sump from the heat exchanger sealing plate and withdraw the sump away from the sealing plate.

The heat exchanger fin matrix is now accessible and the flue ways can be cleaned using a high pressure water hose.

When clean, re-assemble in reverse order using new seals /gaskets where appropriate.

Open the isolating valve and test all joints broken or disturbed for water soundness.

Re-fit the burner assembly. **Test all gas joints broken or disturbed for soundness before firing.**

Refer to **Section 8 Commissioning The Boiler**.

UF100, UF150, UF300 & UF350

UF200 & UF250

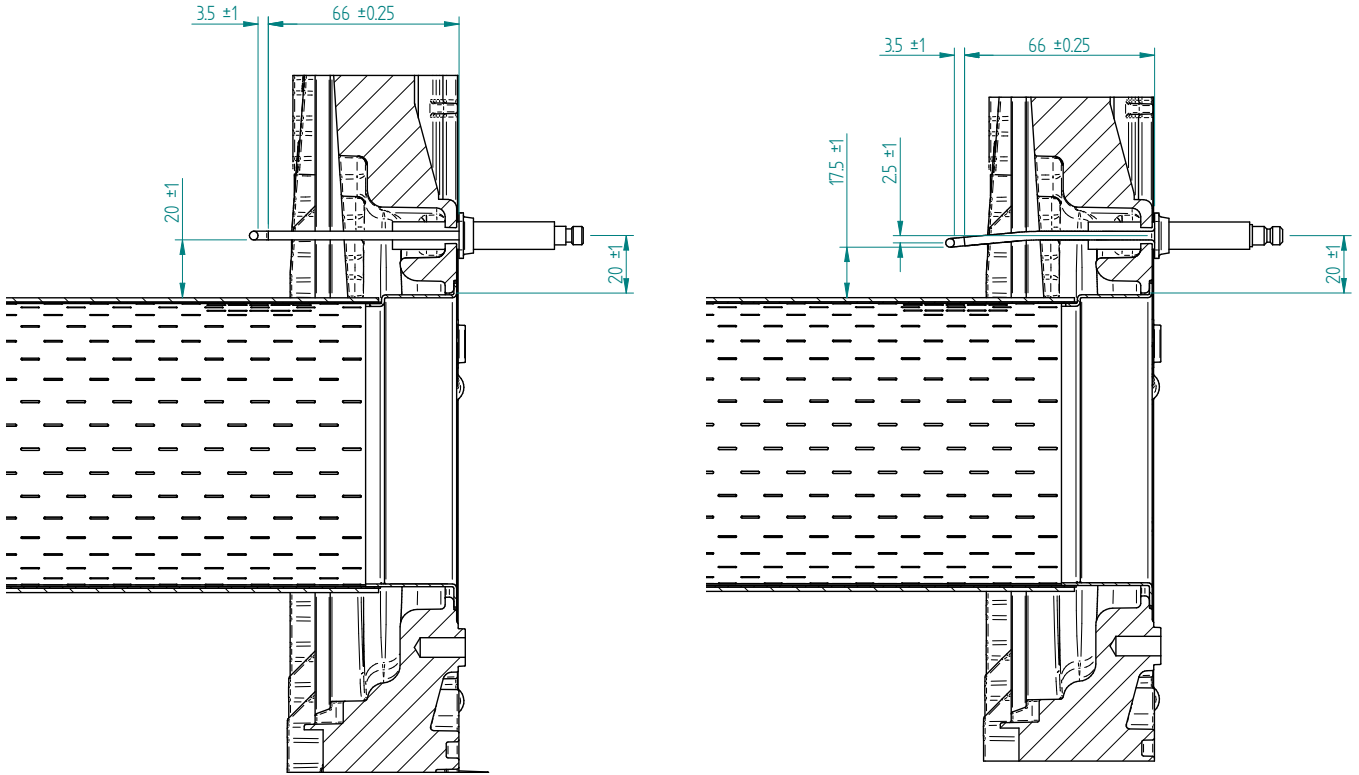

Figure 10.2.1 - Spark Electrode position

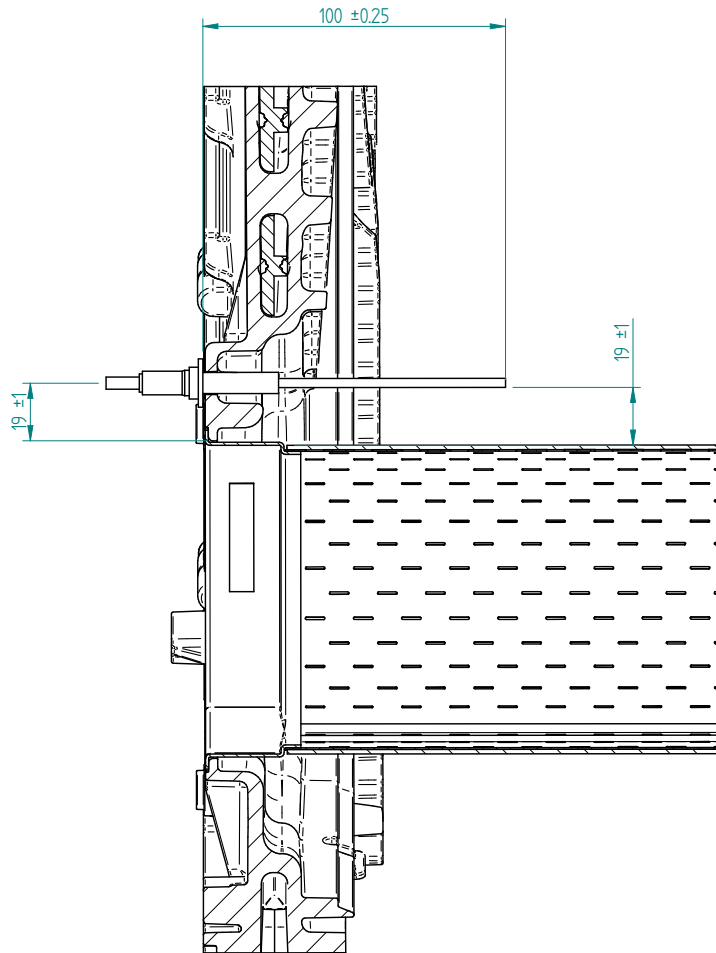

Figure 10.2.2 - Flame Probe position

11.0 REPLACEMENT OF FAILED COMPONENTS

There are a number of components listed below which can be replaced simply and quickly by following the given procedure. In each case the operation of each replaced component must be checked by carrying out the appropriate part of the commissioning procedure. See **Section 8: COMMISSIONING & TESTING**.

Note:- Isolate all electrical supplies to the boiler module before opening the front cover and commencing any servicing or component exchange procedure. Turn off the gas at the service valve.

11.1 HT Electrode and Flame Probe - HT Ignitor Electrode

Part nos. 533805029 UF100, UF150, UF300 & UF350

Part nos. 533805030 UF200 & UF250

Flame Sensing Probe—Part nos. 533805021

Note:- The electrode and flame probe ceramics are very fragile.

Disconnect the HT cable from the electrode. Remove the 2 M4 screws securing the electrode to the heat exchanger and carefully remove the electrode and its gasket. Check the condition of the ceramic, wires and the spark gap. Adjust if necessary. In replacing the electrode, fit a new gasket and take care when feeding the wires through the heat exchanger aperture. Carefully re-connect the HT cable to the electrode.

Disconnect the cable from the flame probe. Remove the 1 M4 screw securing the probe to the heat exchanger and withdraw the probe. Check the condition of the ceramic and wire. In replacing the probe fit a new gasket and refit the cable.

To check the position of the electrode and probe in relation to the burner, remove the burner and refer to Figures 10.2.1 & 10.2.2

11.2 Flow / Return sensor - part no. 533901675

Note: The flow/return sensors are immersed in the water circuit. To remove/replace will require the heat exchanger to be drained.

The two identical sensors are located in the return and flow connections. Prior to removal, check the resistance of the sensor against **Figure B 1.3** In refitting the sensor, a sealant will be required on the threads. Check for water soundness before firing the boiler.

11.3 Flue Gas sensor - Part no. 533901675

The flue gas sensor is located in the flue elbow (175-250) or sump sealing plate (300-350) at the rear of the boiler. Prior to removal, check the resistance of the sensor against **Figure B 1.3** In refitting the sensor, a sealant will be required on the threads. Check for soundness of the joint when firing the boiler.

11.4 Temperature Limiter (Limit Stat)

Part no. 533901583

The limit stat is a bi-metallic disc type located on the front of the heat exchanger assembly, secured by two screws. Disconnect the electrical connections and remove the screws **Beware the terminals are 230v!**

11.5 Water Flow switch

Part no. 533901860 - UF100 & UF150

Part no. 533901859 - UF200 to UF350

Note: The flow switch is immersed in the water circuit. To remove/replace will require the heat exchanger to be drained.

The water flow switch is located in the return pipe on the pump inlet. Undo the union and carefully withdraw the switch assembly from the pipe. The switch consists of a magnetic reed switch providing open or closed circuit. In fitting a replacement switch ensure that a new sealing gasket is used.

11.6 Gas Valve

Part no. 533903044 UF100 & UF150

Part no. 533903036 UF200 to UF300

Part no. 533903045 UF350

All models - isolate the gas supply using the valve located in the bottom left hand corner. To access this valve, first remove the air inlet elbow from the venturi by removing the worm drive clip and 4 - M6 fixing screws. Disconnect the electrical lead and pressure sensing tube.

Remove the 4 - M5 screws securing the inlet fitting to the gas valve. Remove the gas orifice, if fitted (LPG UF200to UF300).

Support the weight of the valve and remove the 4 - M5 screws securing the gas valve to the venturi manifold.

When replacing the gas valve using new 'o' rings and gasket.

All models - reassemble in reverse order and check all joints for gas soundness.

11.7 Fan

Part no. 533704014 UF100 & UF150

Part no. 532418015 UF200 & UF250

Part no. 533704016 UF300 & UF350

To remove the fan it is preferable to remove the complete fan, gas valve and venturi assembly. To access this valve, first remove the air inlet elbow from the venturi by removing the worm drive clip and 4 - M6 fixing screws.

Disconnect the electrical lead and pressure sensing tube from the gas valve.

Disconnect the two electrical plugs (power supply and speed control signal) from the fan motor.

Disconnect the gas supply from the inlet to the gas valve. Carefully disengage the air inlet duct from the venturi. Remove the 4 - M5 screws securing the fan assembly to the burner transition duct. Take care not to drop any screws into the duct opening.

Carefully withdraw the complete assembly and place on a suitable working area.

Remove the screws securing the gas valve and venturi assembly to the fan inlet, noting the position of the venturi.

All models - reassemble in reverse order using new gaskets and check all joints for gas soundness.

11.8 Main control pcb - LMS - refer to spares list

The LMS is located by two screws on the electrical control panel which is secured to the boiler chassis. Carefully disconnect all plug connections from the LMS, taking note of their location. The plugs are polarised to

prevent incorrect fitting.

If a 'clip in module' is fitted, this must be removed and transferred to the new LMS. Carefully disconnect the plug connecting the clip in to terminal X40 or X50. Depress the latch at the plug end of the clip in and disengage the module from the LMS.

Fit the replacement control in reverse order. Remember to apply the parameters local to the installation - refer to section 8.

11.9 Display screen - Part no. 533901691

Remove the control knob from the front of the display, use a pen to push the shaft of the though the securing clip on the back of the display PCB. The display screen is held in place by four clips. Push the display over these four clips using a small screw drive to prise the clips away. Disconnect display ribbon cable from PCB.

Refit ribbon cable to new display PCB and push the display into the display housing past the four retaining clips. Refit control knob

11.10 Low gas pressure switch

Part no. 533901497 UF100 & UF150

Part no. 533925004 UF200 to UF350

Isolate the gas supply using the valve located in the bottom left hand corner.

Disconnect the electrical plug after removing the securing screw. Remove the screw securing the switch to the gas valve body.

When re-fitting a replacement switch remember to set the operating pressure. See Figure A2 Gas Data

11.11 Air Pressure Switch - Part no. 532496004

Disconnect the sensing tube from the switch noting the position. Disconnect the electrical connections noting their position. Remove the 2 screws securing the switch to the control panel. The replacement switch is factory set.

11.12 Air Filter Media - Part no. 532812027

The Upton is fitted with an air inlet filter which is accessed after removing the main front cover of the boiler.

The White filter material can be replaced at service intervals by ordering the part number above available from Hamworthy Heating Ltd spares department.

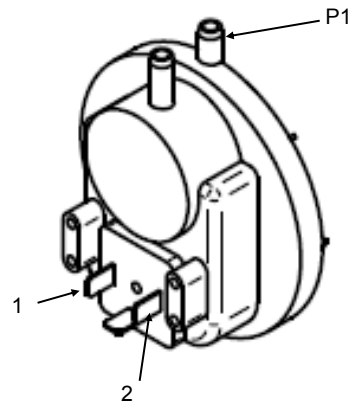

Figure 11.11 Air pressure switch

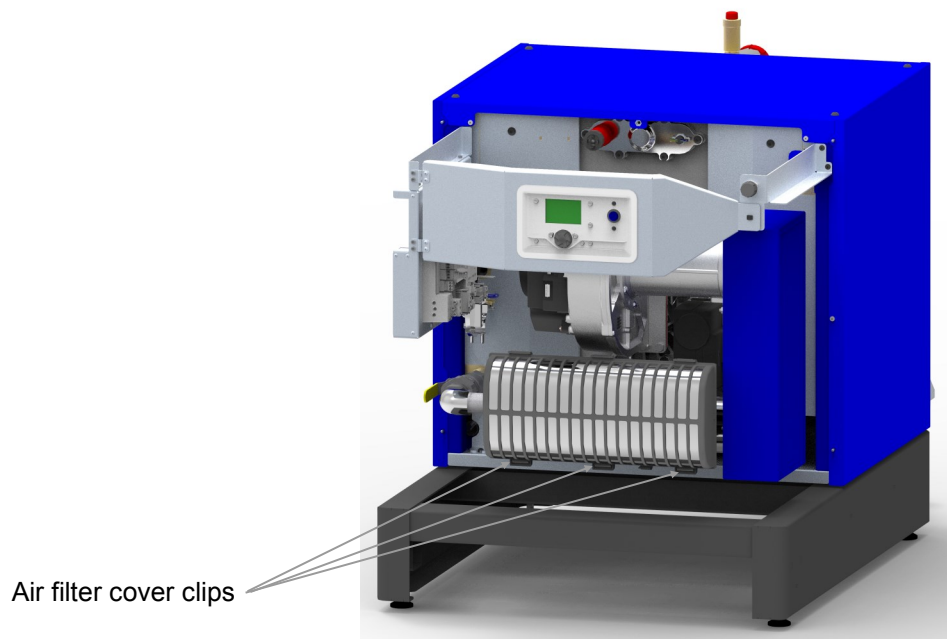

Figure 11.12 Air filter media

12.0 RECOMMENDED SPARES

Please Note:- To ensure the correct spare parts are despatched by our spares department, it is imperative that the complete Boiler/Module/Control Panel Serial Numbers are given. The Boiler and Module Serial Numbers are located on the Data Plates affixed to the combustion chamber front panel. The Electrical Panel Serial Number is located inside the Control panel on the rating label. These numbers **MUST** be quoted when ordering spare parts.

SPARES ITEM	PART No.
ELECTRICAL ITEMS	
Navistem control - UF100-1 Nat Gas.....	179319
Navistem control - UF150-1 Nat Gas.....	179320
Navistem control - UF200-1 Nat Gas.....	179321
Navistem control - UF250-1 Nat Gas.....	179322
Navistem control - UF300-1 Nat Gas.....	179323
Navistem control - UF350-1 Nat Gas.....	179324
Navistem control - UF100-1 LPG.....	179377
Navistem control - UF150-1 LPG.....	179378
Navistem control - UF200-1 LPG.....	179379
Navistem control - UF250-1 LPG.....	179380
Navistem control - UF300-1 LPG.....	179381
Navistem control - UF350-1 LPG.....	179382
Navistem Display PCB.....	179325
Spark Generator 50-60Hz.....	179326
Flow / Return / Flue Temperatue Sensor.....	179327
Water Flow Switch UF100 & UF150.....	179328
Water Flow Switch UF200 to UF350.....	179329
Overheat Thermostat.....	179330
Pressure Sensor.....	179331
HT Ignitor Electrode UF100, UF150, UF300 & UF350.....	179332
HT Ignitor Electrode UF200 & UF250.....	179333
Ht Ignitor Lead.....	179334
Flame Sensing Probe.....	179335
On/Off switch.....	179336
Clip in Module - Fault Alarm & Run Signal - AGU2.550A109.....	179337
Clip in Module - LPB Bus communication - OCI345.06/101.....	179338
MECHANICAL ITEMS	
Burner Fabrication - UF100-1.....	179339
Burner Fabrication - UF150-1.....	179340
Burner Fabrication - UF200-1.....	179341
Burner Fabrication - UF250-1.....	179342
Burner Fabrication - UF300-1.....	179343
Burner Fabrication - UF350-1.....	179344
Gas Control Valve - UF100 & UF150.....	179345
Gas Control Valve - UF200 to UF300.....	179346
Gas Control Valve - UF350.....	179347
Combustion Fan - UF100 & UF150.....	179348
Combustion Fan - UF200 & UF250.....	179349
Combustion Fan - UF300 & UF350.....	179350
Venturi - UF100 & UF150.....	179351
Venturi - UF200 to UF300.....	179352
Venturi - UF350.....	179353
Low Gas Pressure Switch - UF100 & UF150.....	179354
Low Gas Pressure Switch - UF200 to UF350.....	179355
Air Pressure Switch.....	179356
Gasket - gas valve to venturi manifold.....	179357
Gasket - Burner to heat exchanger.....	179358
Gasket - Fan to burner duct UF100 & UF150.....	179359
Gasket - Ignitor.....	179360
Gasket - Probe.....	179361
Gasket - Fan.....	179362
Gasket - Sight Glass.....	179363
View Port Sight Glass.....	179364
Air Inlet Filter Media.....	179365
LPG Gas Orifice - UF200 to UF 300.....	

APPENDIX A - GAS DATA

Figure A1– Gas data

Gas data	MODEL	UF100-1	UF150-1	UF200-1	UF250-1	UF300-1	UF350-1
Gas Inlet Connection Pipe Thread Size		R1 1/4"					
Nominal Inlet Pressure Nat Gas (LPG)	mbar	20 (37)					
Maximum Inlet Pressure Nat Gas (LPG)	mbar	25 (45)					
Gas Pressure Switch Setting Nat Gas	mbar	9.5	6.5	11.0	7.5	6.5	6.0
Gas Pressure Switch Setting LPG	mbar	17					
Gas Flow Rate (max. per module) Nat Gas	m ³ /h	9.8	14.7	19.1	25.0	30.0	34.4
Gas Flow Rate (max. per module) LPG	m ³ /h	3.8	5.7	7.7	9.7	11.6	13.3
Target CO ₂ % at High / Low fire Nat Gas	%	9.0 (±0.2%) / 8.4 (±0.1%)			9.0 (±0.2%) / 8.4 (±0.1%)		
Target CO ₂ % at High / Low fire LPG	%	10.55 (±0.2%) / 9.97 (±0.1%)			10.55 (±0.2%) / 9.97 (±0.1%)		
NO _x Class		6			6		
NO _x .pond,Hs (Gross) emission at 0% O ₂ (dry) Nat Gas	mg/kWh	33	32	33	35	34	36
NO _x .pond,Hs (Gross) emission at 0% O ₂ (dry) LPG	mg/kWh	42.8	44.8	49.0	40.1	47.3	47.1
NO _x .pond,(Nett) emission at 0% O ₂ (dry) Nat Gas	mg/kWh	37	36	36	39	37	39
NO _x .pond,(Nett) emission at 0% O ₂ (dry) LPG	mg/kWh	48.3	48.7	53.3	43.6	51.5	51.2

Figure A2– General data

General Data	MODEL	UF100-1	UF200-2	UF300-3	UF150-1	UF300-2	UF450-3
Maximum Heat Input (Gross)	kW	103.0	206.0	309.0	154.6	309.2	463.8
Maximum Heat Input (Nett) Qn	kW	92.8	185.5	278.3	139.2	278.4	417.6
Minimum Heat Input (Gross)	kW	20.6			30.9		
Maximum Output Condensing Pn 50/30°C	kW	98.6	197.2	295.8	147.3	294.6	441.9
Max Output Non Condensing Pn 80/60°C	kW	89.1	178.2	267.3	134.5	269.0	403.5
Minimum Output/Module 80/60°C	kW	17.8			26.9		
Minimum Output/Module 50/30°C	kW	19.7			29.5		
Ignition Heat Input (Gross)	kW	64.4			83.2		
Nett Efficiency 100% Load 80/60°C	%	86.5			87.0		
Nett Efficiency 30% Load 50/30°C	%	99.3			97.1		
Noise Emission @ 1m (per module)	dB (A)	55.8			59.4		
General Data	MODEL	UF200-1	UF400-2	UF600-3	UF250-1	UF500-2	UF750-3
Maximum Heat Input (Gross)	kW	208.9	417.7	626.6	261.9	523.9	785.8
Maximum Heat Input (Nett) Qn	kW	188.1	376.1	564.2	235.9	471.7	707.6
Minimum Heat Input (Gross)	kW	41.2			51.6		
Maximum Output Condensing Pn 50/30°C	kW	197.9	395.8	593.7	246.9	493.8	740.7
Max Output Non Condensing Pn 80/60°C	kW	181.7	363.4	545.1	229.4	458.8	688.2
Minimum Output/Module 80/60°C	kW	36.3			45.9		
Minimum Output/Module 50/30°C	kW	39.6			49.4		
Ignition Heat Input (Gross)	kW	128.3			102.0		
Nett Efficiency 100% Load 50/30°C	%	87.0			87.6		
Nett Efficiency 30% Load 50/30°C	%	98.2			95.5		
Noise Emission @ 1m (per module)	dB (A)	59.7			58.5		

General Data	MODEL	UF300-1	UF600-2	UF900-3	UF350-1	UF700-2	UF1050-3
Maximum Heat Input (Gross)	kW	314.6	629.1	943.7	360.8	721.6	1082.5
Maximum Heat Input (Nett) Qn	kW	283.3	566.5	849.8	324.9	649.8	974.8
Minimum Heat Input (Gross)	kW	61.9			72.2		
Maximum Output Condensing Pn 50/30°C	kW	295.9	591.8	887.7	348.9	697.8	1046.7
Max Output Non Condensing Pn 80/60°C	kW	273.0	546.0	819.0	316.4	632.8	949.2
Minimum Output/Module 80/60°C	kW	54.6			63.3		
Minimum Output/Module 50/30°C	kW	59.2			69.8		
Ignition Heat Input (Gross)	kW	113.2			132.1		
Nett Efficiency 100% Load 80/60°C	%	86.8			87.7		
Nett Efficiency 30% Load 50/30°C	%	97.2			98.5		
Noise Emission @ 1m (per module)	dB (A)	60.9			60.9		

Figure A3 - Product information - technical parameters required by ErP Regulation (813/2013)

Information requirements for boiler space heaters.							
Models:		UF100-1	UF150-1	UF200-1	UF250-1	UF300-1	UF350-1
Condensing boiler: [yes/no]		yes					
Low temperature boiler: [yes/no]		yes					
B1 boiler: [yes/no]		no					
Cogeneration space heater: [yes/no]		no					
Combination heater: [yes/no]		no					
Item	Symbol Unit						
Seasonal space heating energy efficiency	η_s %	94	92	93	91	92	94
For boiler space heaters and boiler combination heaters: Useful heat output & efficiency							
At nominal heat output and high-temperature regime	P ₄ kW	89.1	131.5	173.4	234.1	256.6	302.0
	η_4 %	86.5	87.0	87.0	87.6	86.8	87.7
At 30 % of nominal heat output and low-temperature regime	P ₁ kW	31.0	45.4	62.4	72.9	88.0	106.4
	η_1 %	99.3	97.1	98.2	95.5	97.2	98.5
Auxiliary electricity consumption							
At full load	e _{lmax} kW	0.139	0.304	0.220	0.285	0.442	0.508
At part load	e _{lmin} kW	0.022	0.028	0.042	0.048	0.045	0.070
In standby mode	PSB kW	0.003	0.003	0.003	0.004	0.003	0.003
Other items							
Standby heat loss	P _{stby} kW	0.196	0.212	0.229	0.279	0.320	0.160
Emissions of nitrogen oxides Nat Gas	Nox mg/kWh	33	32	33	35	34	36
Emissions of nitrogen oxides LPG	Nox mg/kWh	42.8	44.8	49.0	40.1	47.3	47.1

APPENDIX B - ELECTRICAL CONNECTIONS AND CONTROLS

ELECTRICAL DATA - per boiler module	BOILER MODEL		
	UF100	UF150	UF200
Nominal supply voltage	230V ~ 50Hz		
Power Consumption (maximum) W	139	304	220
Start and Run Current (per module) A	0.6	1.3	1.0
	UF250	UF300	UF350
Nominal supply voltage	230V ~ 50Hz		
Power Consumption (maximum) W	285	442	508
Start and Run Current (per module) A	1.2	1.9	2.2

Figure B1 - Electrical supply

B1 ELECTRICAL SUPPLY

IMPORTANT: Individual boilers must be earthed.

The boiler must be isolated from the mains electricity supply in the event of electric arc welding being carried out on any connecting pipe work.

1. Wiring external to the boiler must be installed in accordance with the IEE Regulations and any local regulations which apply. Wiring must be completed in heat resistant 3-core cable of 1.0mm² cross sectional area. Boilers are normally supplied for connection to a 230 volts, 50Hz mains supply. The boiler control is supplied with a replaceable fuse (T6.3A). External fuses should be 10A for all boilers.

2. 3-Phase Electrical Supplies. Individual modules of Upton boilers and any boilers installed in close proximity to each other **MUST NOT** be supplied from different phases of a 3 phase supply. The method of connection to the mains electricity supply must facilitate complete electrical isolation of the single boiler / battery with a separation of at least 3mm in all poles.

3. A mains isolator must be provided adjacent to the boiler in a readily accessible position. The supply should only serve the boiler using the conduits supplied. High and low voltage cables should be separated and routed along individual conduits.

4. Multiple modules. It is highly recommended that each boiler is connected via its own mains isolator to facilitate servicing and maintenance of the individual boiler whilst leaving the remaining boilers in operation.

5. Volt free contact electrical supplies must be isolatable where fitted.

6. Further details regarding connection to the electricity supply are given in BS EN 60335, Part 1.

WARNING: THE MAINS POWER SUPPLY MUST NOT BE SWITCHED BY A TIME-CLOCK CONTROL.

CAUTION: DO NOT FEED MAINS VOLTAGE ONTO THE TIMER TERMINALS

7. The mains power supply must be maintained at all times. Each Upton boiler module incorporates a remote enable link, which can be used to operate the boiler(s) under a timed regime. The boiler controls provide a 24V DC signal that can be fed through a volt free contact for operation. Refer to BS 6644 for further information on installing the electrical supply.

**NOTE: FOR BASIC TERMINATION DIAGRAM SEE FIGURE 4.6
FOR BOILER WIRING SCHEMATIC SEE FIGURE 9.3.1
FOR MULTIPLE BOILER WIRING SEE FIGURE B1.2
FOR CONTROL WIRING SEE FIGURE E1.3.1 TO E1.3.3**

Figure B1.2 - External Control Wiring for Multiple Module Installation

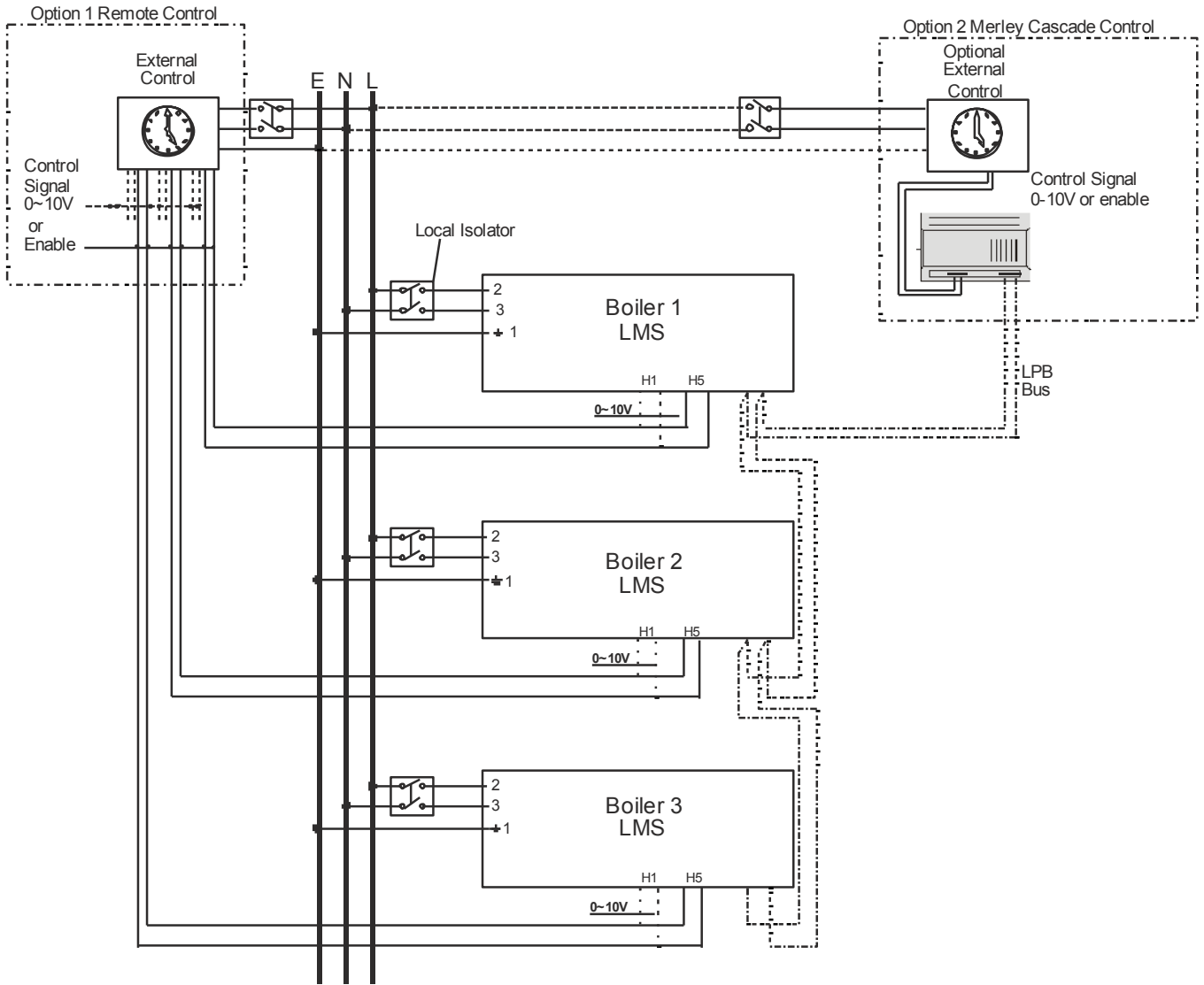

Note:- each module requires independent isolation of electrical supply and control signals. Signal cables must not be run in the same conduit as mains voltage cables

- Option 1 - reference should be made to Building Regulations and CIBSE Guide 'Energy Efficiency in Buildings' for controls requirements.
- All modules must be sequenced.
- Enable - will give On/Off control of the modules
- 0~10V - will give modulation control of each module
- Option 2 provides modulation control of up to 16 modules.

Figure B1.3 - Sensor resistance values

T [°C]	R[Ohm]	T [°C]	R[Ohm]	T [°C]	R[Ohm]
-30.0	175203	50.0	3605	130.0	298
-25.0	129289	55.0	2989	135.0	262
-20.0	96360	60.0	2490	140.0	232
-15.0	72502	65.0	2084	145.0	206
-10.0	55047	70.0	1753	150.0	183
-5.0	42158	75.0	1481	155.0	163
0.0	32555	80.0	1256	160.0	145
5.0	25339	85.0	1070	165.0	130
10.0	19873	90.0	915	170.0	117
15.0	15699	95.0	786	175.0	105
20.0	12488	100.0	677	180.0	95
25.0	10000	105.0	586	185.0	85
30.0	8059	110.0	508	190.0	77
35.0	6535	115.0	443	195.0	70
40.0	5330	120.0	387	200.0	64
45.0	4372	125.0	339		

APPENDIX C - FLUE DATA - Natural Gas & LPG

Figure C1 - Flue Data

	MODEL	UF100-1	UF200-2	UF300-3	UF150-1	UF300-2	UF450-3
Flue Connection (B23p open flue)	mm	130	200	200	130	200	200
Approx. Flue Gas Temperature @ 80/60°C	°C	72			72		
Approx. Flue Gas Temperature @ 50/30°C	°C	42			42		
Approx. Flue Gas Volume @ 9.0% CO ₂ (@ 72°C)	m ³ /h	155	310	465	233	466	699
Maximum Natural Flue Draught - Hot (Cold)	Pa	100 (30)			100 (30)		
Maximum pressure at flue sample point	Pa	120			150		
Pressure available at Flue Connection	Pa	150	150	150	150	150	150
Approximate maximum straight flue length	m	114	267	126	54	126	59
	MODEL	UF200-1	UF400-2	UF600-3	UF250-1	UF500-2	UF750-3
Flue Connection (B23p open flue)	mm	130	250	250	130	250	250
Approx. Flue Gas Temperature @ 80/60°C	°C	72			72		
Approx. Flue Gas Temperature @ 50/30°C	°C	42			42		
Approx. Flue Gas Volume @ 9.0% CO ₂ (@ 72°C)	m ³ /h	314	628	942	394	788	1182
Maximum Natural Flue Draught - Hot (Cold)	Pa	100 (30)			100 (30)		
Maximum pressure at flue sample point	Pa	180			210		
Pressure available at Flue Connection	Pa	150	150	150	150	130	130
Approximate maximum straight flue length	m	31	219	103	20	125	58
	MODEL	UF300-1	UF600-2	UF900-3	UF350-1	UF700-2	UF1050-3
Flue Connection (B23p open flue)	mm	130	300	300	130	300	300
Approx. Flue Gas Temperature @ 80/60°C	°C	72			72		
Approx. Flue Gas Temperature @ 50/30°C	°C	42			42		
Approx. Flue Gas Volume @ 9.0% CO ₂ (@ 72°C)	m ³ /h	474	948	1422	543	1086	1629
Maximum Natural Flue Draught - Hot (Cold)	Pa	100 (30)			100 (30)		
Maximum pressure at flue sample point	Pa	210			210		
Pressure available at Flue Connection	Pa	100	100	80	110	70	60
Approximate maximum straight flue length	m	9	168	63	8	91	37

C1.0 FLUE SYSTEM

1. Detailed recommendations for flue systems are given in BS 6644, and IGE/UP/10. All flue discharges for plant exceeding 150kW output must comply with the third edition of the 1993 Clean Air Act Memorandum.

WARNING: THE FLUE DISCHARGE FROM A UPTON BOILER WILL GENERATE A PLUME AT THE TERMINAL EXIT. THIS MUST BE CONSIDERED WITH REGARD TO TERMINAL LOCATION AND ADJACENT BUILDING FABRIC.

C1.1 General Requirements

The Upton boilers are designed to be used with natural draught flues. Flue systems should be designed in accordance with regulations and with reference to BS 6644 and IGE/UP/10.

Open (Natural draught) Flue.

Type B23p: Flue pressurised, intake from ventilated plant room and discharge via horizontal/vertical flue.–

The following points should be noted:

- Due to the high thermal efficiency of the boiler condensation in the flue will occur. It is strongly recommended that twin wall or insulated flue pipe is used on all installations.
- Care should be taken to ensure that the flue is installed such that any condensation is continuously drained. Any flue system with a horizontal section should have a maximum slope of 3° upwards in the direction of the exhaust gas flow. All joints should be such that any condensation is directed back down the slope to an open

drain connection in the flue. The drain pipe must be manufactured from a corrosion resistant material and at least 15mm diameter. It must have a fall of at least 3° (approx. 50mm/meter) and connect to a drain via a waste trap.

c. Boiler flue outlet sizes - A flue system designed with the same diameter as the boiler flue outlet may not provide satisfactory performance in all applications. Conversely a flue system designed with a smaller diameter than the boiler flue outlet may provide satisfactory performance. Consideration must be given to the correct calculation of the required flue size. If in any doubt consult Hamworthy Heating Ltd who working in partnership with Midtherm Engineering Ltd can provide a comprehensive flue design and installation package.

C1.2 Waste Gas Volume and Temperature.

It is recommended that the volume and temperature of the waste gases used for design of the flue system are as given in the above tables.

C1.3 Materials.

Materials used for the flue system must be mechanically robust, resistant to internal and external corrosion, non-combustible and durable under the conditions to which they are likely to be subjected. Consideration must be given to avoid possible freezing of condense water traps and pipe work.

C1.4 Suction

The flue system must be designed acknowledging that there is a positive pressure generated by the boiler combustion fan. Refer to table Appendix C.

The flue system must be designed to limit the max. suction to 100Pa (negative). This condition must be checked hot and with all boilers firing, the max. pressure at the flue sample point should not exceed the values in Appendix C.

Any stabiliser fitted must be in or close to the vertical chimney.

Fan Dilution - The design must provide for the use of balancing and trim dampers, and their location and operation must be such that the constraints detailed above can be met. Care must be taken to ensure that the fan performance is matched to deliver the appropriate dilution, whilst ensuring that excessive suction is not applied to the boilers. If in doubt, refer to HHL Technical.

C1.5 Disconnection

Provisions should be made for disconnection of the flue pipe for servicing. It is advisable that bends are fitted with removable covers for inspection and cleaning as appropriate.

**WARNING: THE FLUE SYSTEM MUST BE SELF SUPPORTING AND NOT PRESENT
A RISK TO PEOPLE IN OR AROUND THE BUILDING.**

C1.6 Flue Discharge

The flue system must ensure safe and efficient operation of the boiler protecting the combustion process from wind effects and dispersing the products of combustion to the external air. The flue must terminate in a freely exposed position and be so situated as to prevent the products of combustion entering any opening in a building. Where the flue diameter is less than 204mm (8") diameter a terminal must be fitted. Where the flue is of a larger size, consideration should be given to the fitting of a flue discharge terminal or grille to stop ingress of birds etc.

C1.7 Surface Temperatures

Combustible materials in the vicinity of the boiler and flue shall not exceed 65°C during boiler operation. The flue shall not be closer than 50mm to any combustible material, except where it passes through such material with a non-combustible sleeve when the air gap may not be less than 25mm.

C1.8 Location

The flue system must not be placed or fitted where there is undue risk of accidental damage to the flue pipe or undue danger to persons in the vicinity. Check that the flue and chimney are clear from any obstruction. Upton boilers are suitable for installation in a balanced compartment in accordance with the requirements of BS 6644. Consult Hamworthy Heating Technical Department for help or assistance if in doubt.

C1.9. Condensate Discharge

Due to the high thermal efficiency of the boiler, condensation will occur within the boiler casing during firing from cold conditions. A drain with an integral trap is fitted to each module suitable for connection to a 34mm o.d. Polypropylene plastic waste pipe (not Hamworthy Heating Ltd supply), which must be connected to a tundish (not Hamworthy Heating Ltd supply). Discharge piping from a tundish should be of synthetic material due to the mild

acidity of the condensate (pH3-5), with all discharge piping having a minimum fall of 50mm/m away from the boiler. Consideration should be given to possible freezing of condense water traps and pipe work. This must be avoided at all times by routing pipe work within the building, where possible.
In addition to the above the stacked module arrangement flue boxes are supplied with a trap terminating in a 32mm i.d. connection, which should be connected in a similar manner to a drain.

APPENDIX D - VENTILATION

D1.1 Air Supply

Detailed recommendations for air supply are given in BS 6644 and BS5440 Pt 2. The following notes are intended to give general guidance. In all cases there must be provision for an adequate supply of air for both combustion and general ventilation, in addition to that required for any other appliance.

Note: The combustion air for the boiler is drawn through the rear of the boiler. The air inlets **must** be kept open and free from blockage at all times.

LPG - installations. It is strongly recommended that gas detection equipment is fitted. This equipment should be positioned near the boiler(s) and at low level. The space housing the boiler(s) must be ventilated at high and low level in accordance with the following;

D1.2. Air Supply by Natural Ventilation - Open Flue applications

The boiler room must have, or be provided with, permanent air vents directly to the outside air, at high level and at low level. For an exposed boiler house, air vents should be fitted, preferably on all four sides, but at the least on two sides. Air vents should have negligible resistance and must not be sited in any position where they are likely to be easily blocked or flooded or in any position adjacent to an extraction system which is carrying flammable vapour. Grilles or louvres must be so designed that high velocity air streams do not occur within the space housing the boiler.

Boiler house ventilation

Low level (inlet) - 4cm² per kW of total rated input (Net)
High level (output) - 2cm² per kW of total rated input (Net)

Compartment ventilation

Where the boiler is to be installed in a cupboard or compartment, permanent high and low level ventilation is required which must communicate direct to outside, for cooling purposes.

Low level (inlet) - 10cm² per kW of total rated input (Net)
High level (output) - 5cm² per kW of total rated input (Net)

D1.3 Air Supply by Mechanical Ventilation

Air supplied to the boiler room by Mechanical means should be as follows:

- 1) Mechanical ventilation must be interlocked with the boilers to prevent operation in the event of ventilation fan failure
- 2) Mechanical extract ventilation with natural inlet ventilation **MUST NOT** be used.

For Mechanical ventilation systems an automatic control should be provided to cut off the gas supply to the boiler, in the event of failure of air flow in either inlet or extract fans.

D 1.4. Boiler House Temperatures

The air supplied for boiler house ventilation shall be such that the maximum temperatures within the boiler house shall be as follows:

At floor level (or 100mm above floor level) = 25°C.

At mid-level (1.5m above floor level) = 32°C.

At ceiling level (or 100mm below ceiling level) = 40°C.

D 1.5. General Requirements

The air supply should be free from contamination such as building dust and insulation fibres from lagging. To avoid unnecessary cleaning and servicing of the boiler modules, the boilers should not be fired whilst building work is being undertaken.

High and low level ventilation grilles shall be positioned as high and as low as practicably possible. Low level grilles should be located within 1 metre of the floor for Natural Gas and within 250mm of the floor for LPG. High level grilles should be positioned within 15% of the boiler room height from the ceiling. High and low level grilles shall communicate with the same room or space where compartment ventilation is used. Where grilles communicate directly with outside air, they shall be positioned on the same wall.

Figure D1 Mechanical Ventilation Flow Rates

	Flow rate per kW total rated heat input (Net)	
	Inlet air (Combustion ventilation)	Difference between Inlet & Extract air *
	m ³ /h.	m ³ /h.
Volume	2.6	1.35

Note * : Where the associated air extraction is also by means of a fan, this shall be selected such as not to cause a negative pressure to develop in the boiler house and to maintain the difference between inlet and extract flow rates shown above.

The calculated extract flow rate is the actual inlet flow rate minus the appropriate figure in the table above.

APPENDIX E - WATER DATA

Figure E1 - Water Data	MODEL	UF100-1	UF150-1	UF200-1	UF250-1	UF300-1	UF350-1
Water connections (Flow & Return)	BSP	R2"					
Maximum Water Pressure PMW	Bar g	6.0					
Maximum Operating Pressure	Bar g	5.3					
Minimum Operating Pressure (not including pipe kit)	Bar g	0.5					
Minimum Operating Pressure with pipe kit	Bar g	1.0		1.2		1.5	
Water content (not including pipe kit)	l	9.0	12.6	16.2	19.8	23.4	27.0
Design Flow Rate @ 20°C ΔT Rise	l/s	1.2	1.8	2.4	3.0	3.6	4.2
Waterside Pressure Loss @ 20°C ΔT Rise	m/bar	225	250	217	234	246	255
Flow Temperature Set Point (default setting)	°C	80°C					
Maximum flow temperature setting	°C	85°C					
Minimum flow temperature setting	°C	30°C					

Figure E1.1 Hydraulic Resistance

Hydraulic Resistance - Upton

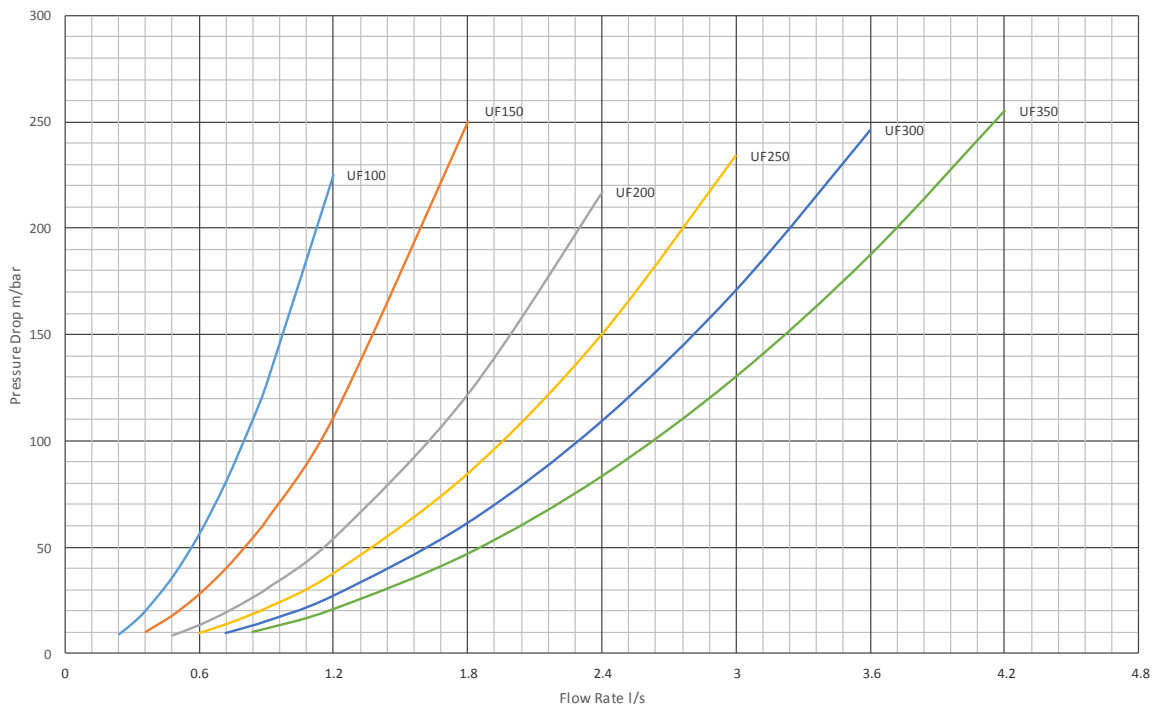

E1.1 Water Circulation System

The Upton boiler has a low water content and the requirements of minimum water flow are given in the above table. Recommendations for the water circulation system are given in BS 6644 and CP 342.

The following details are of particular importance for the correct installation of the water circulation system:

- 1) In a combined central heating and hot water system the hot water storage vessel must be of the indirect cylinder or calorifier type. The hot water storage vessel should be insulated, preferably with not less than 75mm (3") thick mineral fibre, or its thermal equivalent.
- 2) Circulating pipe work not forming part of the useful heating surface should be insulated to help prevent heat loss and possible freezing, particularly where pipes are run through roof spaces and ventilated cavities. Cisterns situated in areas which may be exposed to freezing conditions should also be insulated. Furthermore, insulation exposed to the weather should be rendered waterproof.
- 3) Drain valves must be located in accessible positions which permit the draining of the whole system, including the boiler and hot water storage vessel.
- 4) Each boiler module has flow and return connections as detailed in the table above. Multiple boilers should be connected by flow and return headers. Hamworthy strongly recommend that boilers are connected in a primary circuit configuration utilising a low loss header arrangement to enable secondary circuits to be connected to the header. Figure E1.1.1 on the following page show typical layouts.
- 5) Ideally, individual valves should be fitted to each module to enable isolation from the system, however, the arrangement must comply with the requirements of BS 6644.

E1.2 Pressure Relief Valve (Safety Valve)

The most important single safety device fitted to a boiler is its safety valve. Each boiler module is provided with a G $\frac{3}{4}$ " connection for the fitting of a safety valve (not supplied). BS 6644 provides comprehensive information for the selection and location of safety valves and attention is drawn to the higher capacity requirements of safety valves for pressurised hot water systems. For boilers in excess of 300kW nominal heat output the Navistem controls can be configured to shut off the boiler before the safety valve operates.

E1.3 Altitude Gauge (Water Pressure Gauge)

The system pressure can be accessed from the HMI control panel.

E1.4 Water flow protection.

Each boiler is provided with an integral flow switch to shut off the boiler if there is insufficient through the heat exchange.

E1.5 Thermometer

A thermometer complete with pocket should be fitted in the pipe work to indicate water flow temperature. See Figure E1.1.1 for typical position.

E1.6 Drain Valves

Each boiler has a 15mm NB drain valve fitted in front of the heat exchanger, for draining the boiler only. The heating system in total should have drain valves as recommended by BS 6644. See Figures E1.3.1 to E1.3.7 for typical position.

E1.7 Circulating Pump

One or more circulating pumps will be required to circulate water around the boilers and heating system. The pump should be sited to facilitate servicing. It is important that when Upton boilers are used to replace boilers on an existing system, the pumps should be checked for performance against the new boiler waterside pressure loss to ensure that the minimum flow rate can be obtained. It is also important that the existing system be flushed through twice to remove any loose matter which may have accumulated. If in any doubt regarding the cleanliness of the system, a coarse filter should be fitted in the return pipework to the boilers.

If boilers are run off time clock control a pump overrun (not Hamworthy Heating Ltd supply) should be fitted which must run for a minimum of 5 minutes on shutdown of the last boiler. This must be interlocked to the Navistem B3000 boiler control for frost protection.

E1.8 Minimum Water Flow Rates

Minimum water flow rates are shown in table at beginning of Appendix E. These flow rates should be maintained through the boiler at all times whilst the boiler is firing. To prevent the boiler firing in the event of poor or no flow, the boiler is fitted with an integral flow switch. Particular attention should be paid to the restriction of external flow circuits during periods of low heat demand.

E1.9 Waterside Pressure Drop

The waterside hydraulic resistance (Pressure drop) is given in table at beginning of Appendix E.

E1.10 Water Flow Controls

Any external mixing valve / shunt pump or similar controls MUST always ensure that the minimum water flow rate as given in table at beginning of Appendix E is maintained. As a precaution, the Upton boiler is fitted with a flow switch. The flow switch is designed to operate such that the boiler will shut down if insufficient flow occurs.

E1.11 Frost Protection

Consideration should be given to fitting an optional outside air sensor, to provide the necessary frost protection.

E1.12 Unvented Systems

For system design refer to BS 7074 Part 2. In order to correctly size a pressurisation unit for any heating system the following parameters are required.

- 1) Static height of highest component in system (metres)
- 2) System volume. If this is not known, a general rule of thumb of 10litres/kW of installed boiler power can be used.
- 3) Maximum flow temperature (°C)
- 4) Maximum system hot working pressure, generally given in bar gauge.

From the parameters given, Hamworthy Heating can size the pressurisation unit and also the expansion vessel. Care must be taken in sizing expansion vessels to ensure maximum acceptance factors are not exceeded. Normally manufacturers of vessels impose a limit of 0.5. This value must not be exceeded at any time during the operation of the boiler, this includes the over pressure condition should a safety valve lift. Consideration should also be given to sizing of the safety valve(s) in the system.

E 1.13 Minimum System Water Pressure

To comply with guidance note **INDG436 (Health and Safety Executive)**, the minimum pressure requirements at the boiler are given below :-

Individual boiler @ 82°C	0.5 bar
Multiple boilers	
With flow isolation (pump or valve) @ 82°C.....	0.5 bar
Without flow isolation @ 20°C rise across the system @ 82°C.....	1.0 bar

Please note that the maximum flow temperature available from the controls is 85°C

E1.14 Pressure Limiter

Each boiler is fitted with a pressure limiter to shutdown the boiler if the pressure exceeds the maximum or minimum operating limits.

Hydraulic Schemes: For Single Boiler Installations

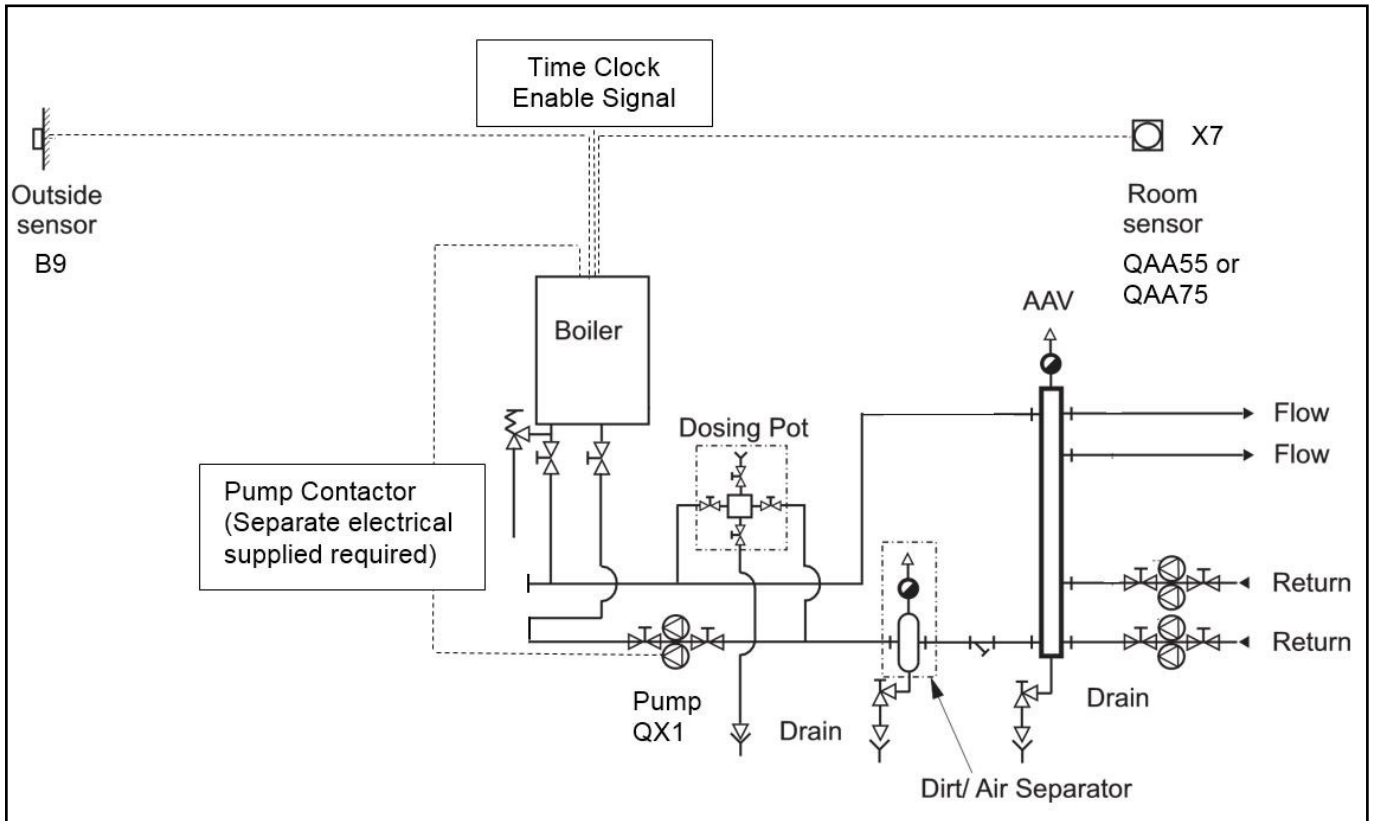

Figure E 1.3.1 - Schematic 1 - External Time Clock Enabled Boiler

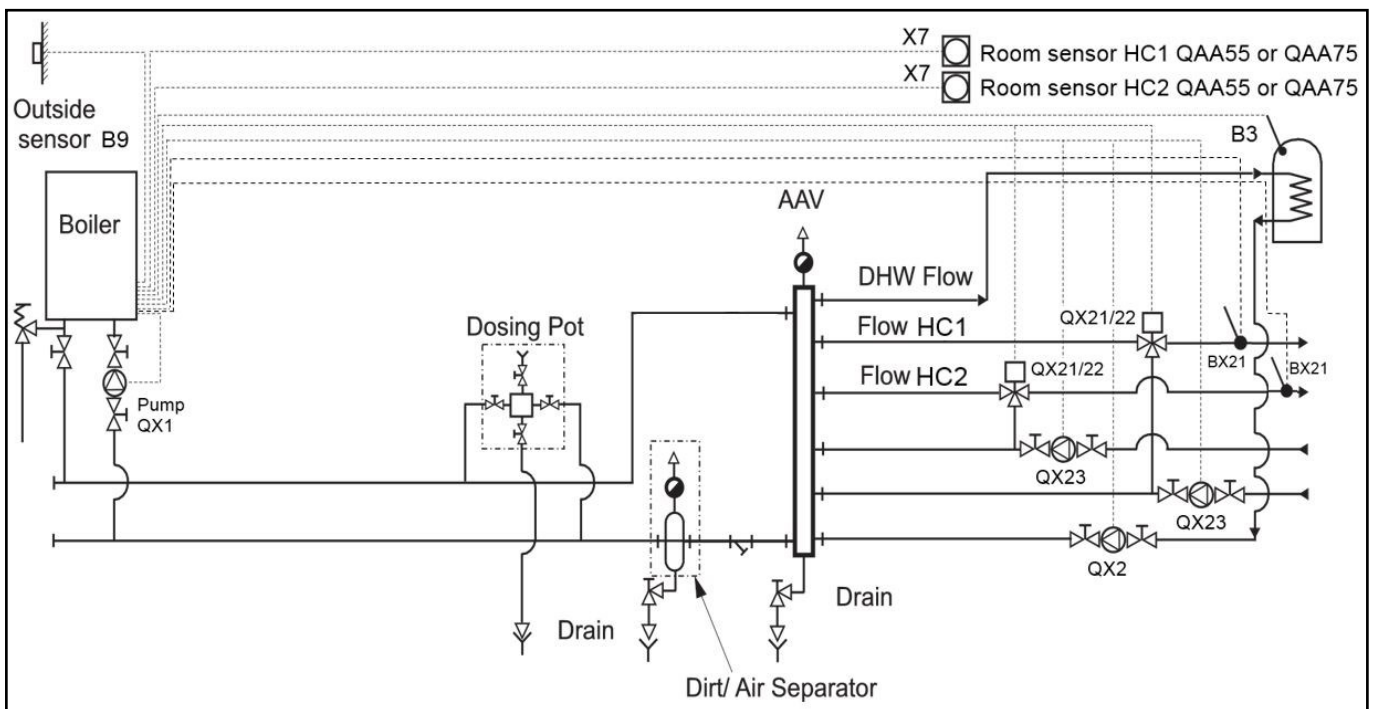

Figure E 1.3.2 - Schematic 2 - Two Heating Circuits with DHW & Boiler Shunt Pump

Hydraulic Schemes: For Multiple Boiler Installations

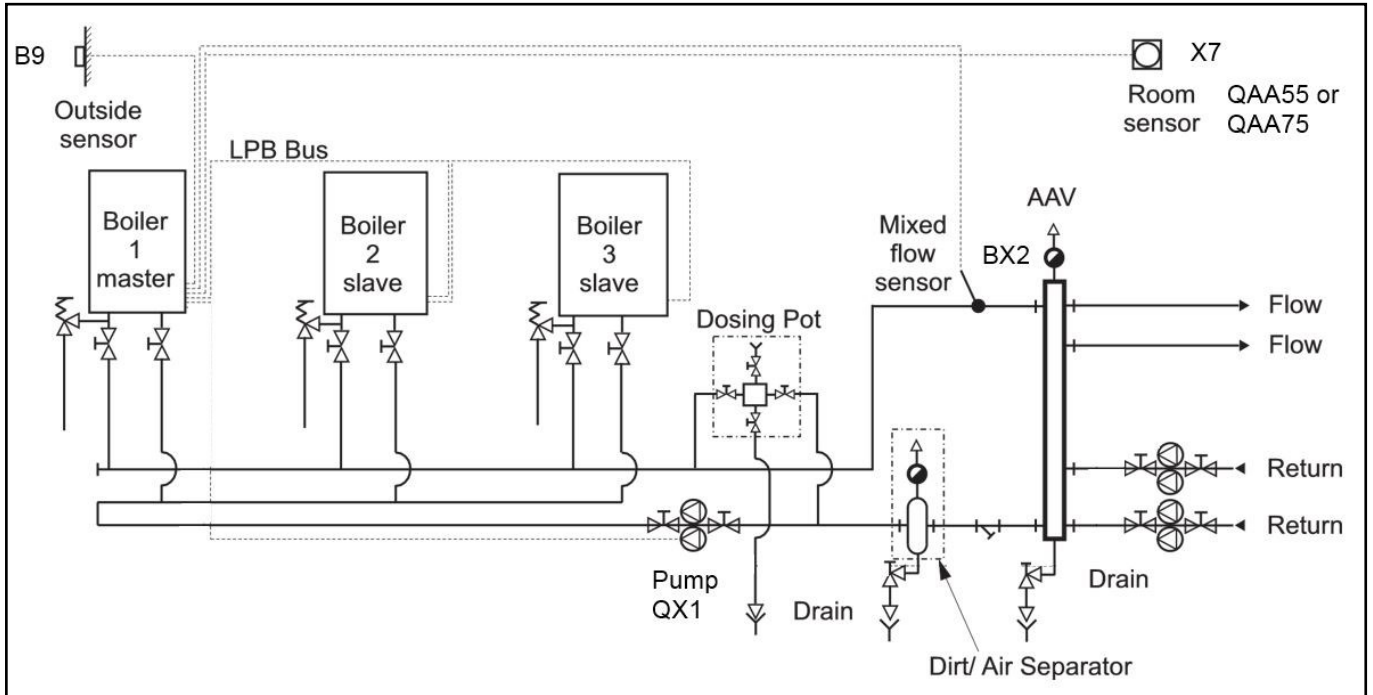

Figure E 1.3.3 - Schematic 3 - Master and Slave Sequence Control With Reverse Return Primary

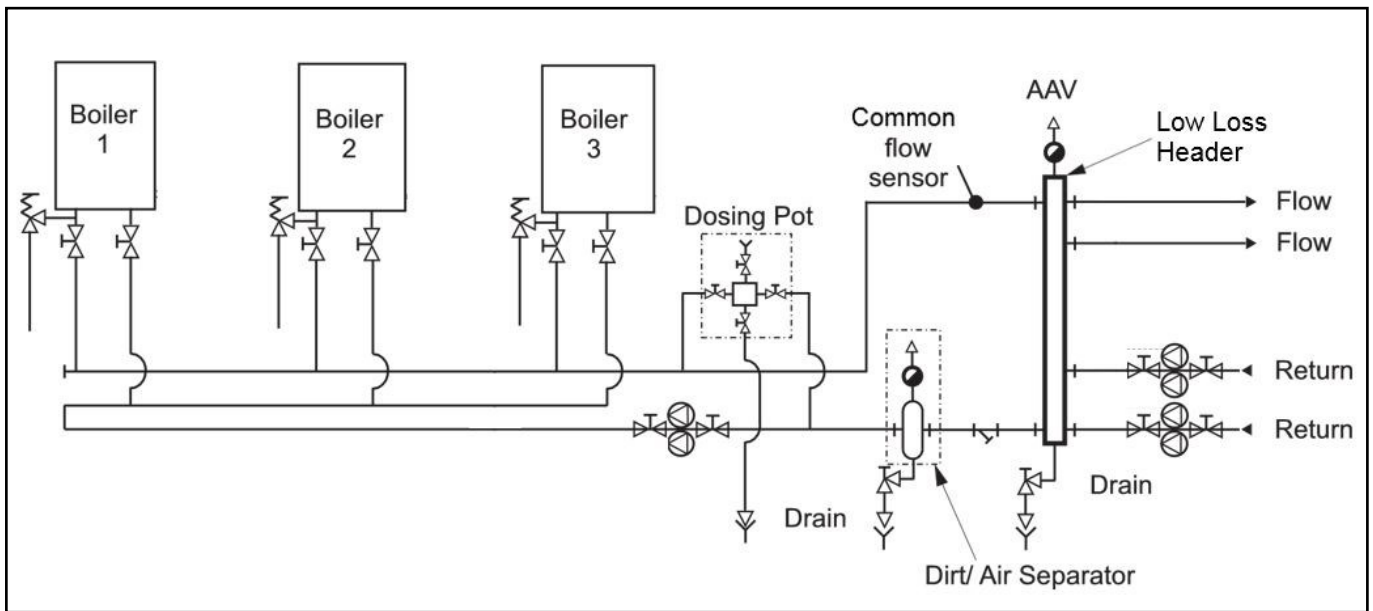

Figure E 1.3.4 - Schematic 4 - Reverse Return Primary Circuit

Hydraulic Schemes:

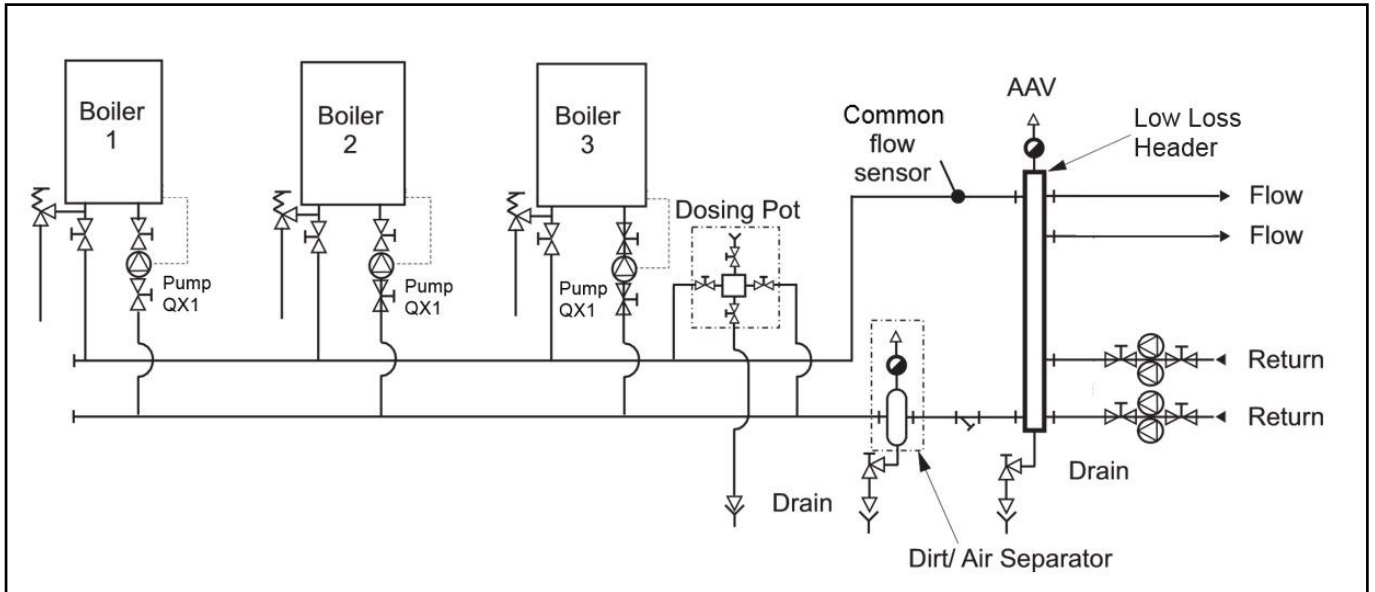

Figure E 1.3.5 - Schematic 5 - Primary Circuit With Individual Boiler Shunt Pumps

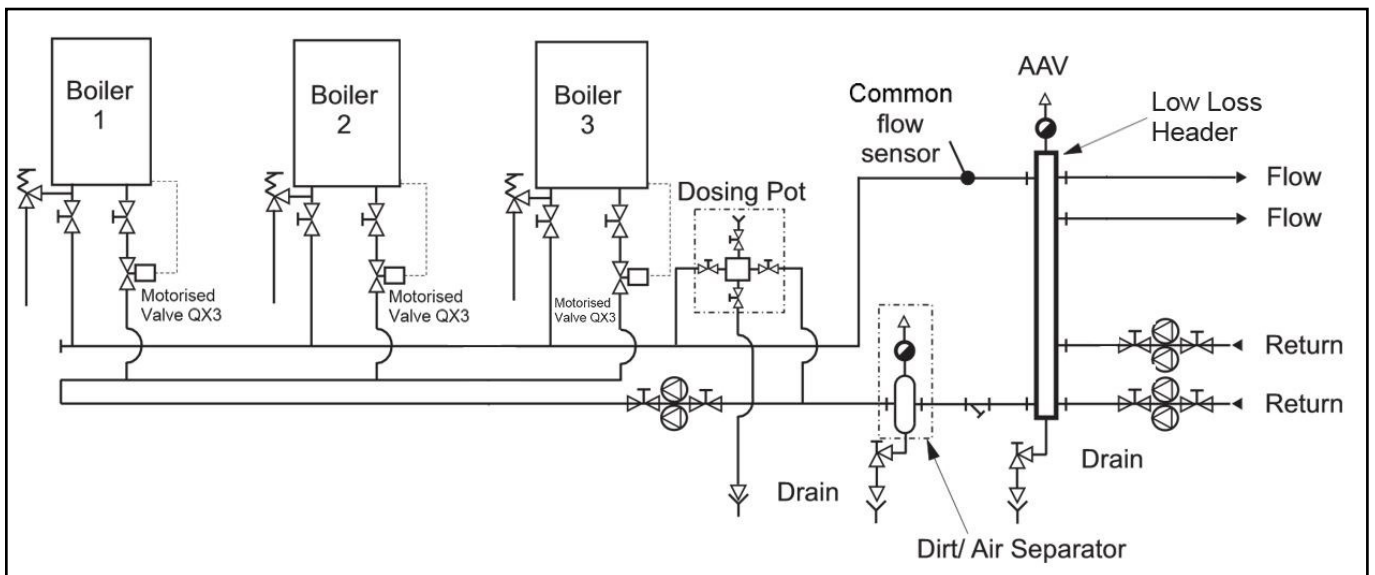

Figure E 1.3.6 - Schematic 6 - Reverse Return Primary Circuit with Individual Motorised Boiler Isolation

Note:

Motorised valves can be either power open/power close or power open/spring return close.

Boiler Parameter Settings: Single Boiler

Fault Alarm and Run Signal

Parameters are pre-programmed into Navistem Controller.

Extension module AGU2.550A109 is required for each boiler. Set the dip switch to 1. The parameters in the LMS are set to acknowledge module No.1 as the VFC outputs

Note: A maximum of three extension modules can be accommodated per boiler. Using this option reduces the number of addition heating circuits that can be controller by the boiler from three to two.

Connections on extension module AGU2.550A109.

Volt Free Connections

L (1) Low voltage supply (24v Signal)

QX21 (7) - Switch Closed - Run Signal

QX22 (5) - Switch Closed - Fault Signal

Mains Supply 230V Signal

L (1)- connected to AUX2 L

N (2) - connected to AUX2 N

QX21 (7) - Switch Live - Run Signal

N (4) - Neutral - Run Signal

QX22 (5) - Switch Live - Fault Signal

N (6) - Neutral - Fault Signal

Enable with external time clock for constant temperature

Legend E = End user I = Commissioning F = Heating engineer

<u>Menu</u>	<u>Operating Line</u>	<u>User Level</u>	<u>Function</u>	<u>Setting</u>
LPB System	6600	F	Device address	1
	6630	F	Cascade Master	Automatically
Configuration	5710	F	Heating circuit 1	Off
	5977	F	Function of input H5	Consumer request VK1
Consumer Circuit 1	1859	F	Flow temperature setpoint	80°C or as required

Note:

Use H5 wiring connection to enable boiler requires volt free enable from time clock.

Optional extras required for this configuration:

None

Boiler Parameter Settings: Individual Boiler Shunt Pumps 0-10v

Using the boiler control to set the pump speed (pumps with 0-10v control).

Legend E = End user I = Commissioning F = Heating engineer

<u>Menu</u>	<u>Operating Line</u>	<u>User Level</u>	<u>Function</u>	<u>Setting</u>
Boiler	2323	F	Pump speed maximum	% Set as required to achieve 20°C temperature differential
	2322	F	Pump speed minimum	Same % value as 2323
Diagnostics Heat Generation	8310	F	Display boiler flow temp.	Display only
	8314	F	Display boiler return temp.	Display only

The pump is defaulted to pump speed min 100% & pump speed max 100% to adjust these values you will need to do the following.

On the HMI press **OK**, time and date will appear.

- Press and hold the **I** button for 3-5 seconds

- Enduser will be displayed on the screen use rotary knob to select Engineer press **OK**, Time and date will be displayed on the screen.
- Use rotary knob to select Boiler.
- Use rotary knob to select line number 2322 pump speed min, press **OK** 100% will flash adjust as required then press **OK**.
- Use rotary knob to select line number 2323 pump speed max, press **OK** 100% will flash adjust as required to match min speed then press **OK**.
- When finished press ESC twice to return to main screen on HMI.
- On the HMI press **OK**, time and date will appear.
- Press and hold the I button for 3-5 seconds
- Enduser will be displayed on the screen use rotary knob to select Engineer press **OK**, Time and date will be displayed on the screen.
- Use rotary knob to select Diagnostics heat generation press **OK**.
- Use rotary knob to select line number 8310, Boiler flow temp will be displayed on the screen.
- Use rotary knob to select line number 8314, Boiler return temp will be displayed on the screen.

Optional extras required for this configuration:
Hamworthy Flow and return manifold kit

Boiler Parameter Settings: Individual Boiler Shunt Pumps (Relay Output QX1)

Legend E = End user I = Commissioning F = Heating engineer

<u>Menu</u>	<u>Operating Line</u>	<u>User Level</u>	<u>Function</u>	<u>Setting</u>
Configuration	5890	F	Relay output QX1	Boiler pump Q1

Optional extras required for this configuration:
None

Boiler Parameter Settings: Single Boiler

External time clock with weather compensation

Legend E = End user I = Commissioning F = Heating engineer

<u>Menu</u>	<u>Operating Line</u>	<u>User Level</u>	<u>Function</u>	<u>Setting</u>
LPB System	6600	F	Device address	1
	6630	F	Cascade Master	Automatically
Heating Circuit 1	900	F	Operating mode Changeover	Automatic
Configuration	5710	F	Heating circuit 1	On
	5977	F	Function of input H5	HCS
	5978	F	Contact type H5	NC
Heating Circuit 1	740	F	Flow temp min set point	50
	741	F	Flow temp max set point	80
	720	F	Heating curve slope	3
	726	F	Heating curve slope adaption	On
Operation section	26	F	Operation lock	On
Hot water mode	No display			

Note:
Use H5 wiring connection to enable boiler requires volt free enable from time clock.

Optional extras required for this configuration:

External air sensor	– QAC34	Part number 533901457
Room sensor choice	– QAA55—Offset adjustable room sensor	Part number 533901589
	– QAA75—Programmable room sensor	Part number 533901587

Boiler Parameter Settings: Individual Boiler Flow Isolation Using Motorised Valve

Legend E = End user I = Commissioning F = Heating engineer

<u>Menu</u>	<u>Operating Line</u>	<u>User Level</u>	<u>Function</u>	<u>Setting</u>
Configuration	5892	F	Relay output QX3	Boiler pump Q1

Note:

The QX3 terminals have live outputs on NO & NC connection together with neutral & earth this will facilitate powering the valve open and closed.

Optional extras required for this configuration:
None

Boiler Parameter Settings: Single Boiler

Internal time clock with two heating circuits, DHW & boiler shunt pump

Legend E = End user I = Commissioning F = Heating engineer

<u>Menu</u>	<u>Operating Line</u>	<u>User Level</u>	<u>Function</u>	<u>Setting</u>
Configuration	5890	F	Relay output QX1	Boiler pump Q1
	5931	F	Sensor input BX2	Common flow Sensor B10
	5977	F	Function input H5	None
	5710	F	Heating Circuit 1	On
	5715	F	Heating Circuit 2	On
	6021	F	Function extension Module 2	Heating Circuit 1
	6022	F	Function extension Module 3	Heating Circuit 2
	6054	F	Function input H2 Module 2	Room Stat HC1
	6062	F	Function input H2 Module 3	Room Stat HC2
	Domestic Hot Water	1610	F	Nominal Set Point

Domestic Hot Water - additional parameters may need to change

Extension module AGU 2.550A109 are require for each addition heating circuit to be controlled. Maximum of three additional extension modules can be accommodated per boiler.

Heating mode Auto symbol
Hot water mode On

Note:

For this application, the Function extension modules 2 & 3, with respect to their parameter setting as heating circuits 1 & 2, have pre-defined outputs for each extension module as shown in the table below.

	Wiring connections on heating circuit extension module AGU 2.550A109					
	QX21	QX22	QX23	BX21	BX22	H2
Multifunctional	*	*	*	*	*	*
Heating circuit 1	Y1	Y2	Q2	B1	*	*
Heating circuit 2	Y5	Y6	Q6	B12	*	*
Heating circuit 3	Y11	Y12	Q20	B14	*	*

Note:

To check operation of pumps, mixing valves & thermostats select: engineer – diagnostic consumers – parameters 8730 to 8779

Optional extras required for this configuration:
2x Heating circuit extension modules AGU2.55A109

Part number 563605669

Heating sensor kit	– QA236	Part number 563605673
2x Room sensor choice	– QAA55—Offset adjustable room sensor	Part number 533901589
	– QAA75—Programmable room sensor	Part number 533901587
DHW sensor kit	– QA236	Part number 563605674

Connections on heating circuit extension module AGU2.550A109:

QX21—Switched live—Mixing valve opening

QX22—Switched live—Mixing valve closing

QX23—Switched live—Heating circuit pump (Contactor required for pump)

BX21—Flow temperature sensor—Heating circuit

H2—Heating circuit room thermostat—Basic type no/nc switch vfc (Only use if optional room sensor QAA55 or QAA75 are not specified)

Boiler Parameter Settings: Multiple Boilers

Sequence control using integral Master and Slave configuration

Single primary pump set for fixed flow rate operation (pump will have to be low energy type)

The table below shows all available settings up to the heating engineer level. However, certain operating lines may be hidden, for security purpose

Legend E = End user I = Commissioning F = Heating engineer

<u>Menu</u>	<u>Operating Line</u>	<u>User Level</u>	<u>Function</u>	<u>Setting</u>
LPB System	6600	F	Device address	Boiler 1 set to 1 (master) Boiler 2 set to 2 Additional boilers set to 3, 4 ect.
	6601	F	Segment address	Boilers all set to 0
	6640	F	Clock mode	Boilers 1 set to Master Boilers additional set to Slave with remote setting
	6630	F	Cascade	Boiler 1 set to always Boilers additional set to Autonomously
Configuration	5710	F	Heating Circuit 1	Boiler 1 set to on Boilers additional set to off
	5890	F	Relay output QX1	Boiler 1 set to Cascade pump Q25
	5931	F	Sensor input BX2	Boiler 1 Master Common flow sensor B10 Boilers additional set to none
	6117	F	Central compensation set up	Boilers all set to 5
	6200	F	Save sensors	Boilers all set to yes

Internal time clock settings

Settings must be programmed to master boiler

<u>Menu</u>	<u>Operating Line</u>	<u>User Level</u>	<u>Function</u>	<u>Setting</u>
Time program	500	E	Mon-sun: Mon-Fri:	As req
Heating Circuit 1	501	E	1st period on	
	502	E	1st period off	
	503	E	2nd period on	
	504	E	2nd period off	
	505	E	3rd period on	
	506	E	3rd period off	
Configuration	5710	F	Heating circuit 1	On

External enable—e.g. Remote time clock

Settings must be programmed to master boiler

<u>Menu</u>	<u>Operating Line</u>	<u>User Level</u>	<u>Function</u>	<u>Setting</u>
Configuration	5710	F	Heating circuit 1 1—on/off	On
	5950	F	Function of remote Input H1	Operating mode changeover HC1
	5951	F	Define time clock Switch—no/nc contacts	As required
Heating mode	Auto symbol			
Hot water mode	Off			

Optional extras required for this configuration:

Heating sensor kit – QA236

LPB bus communication module OC1345—one per boiler module

Part number 563605673

Part number 563605667

Boiler Parameter Settings: Multiple Boilers

Individual boilers enabled from B.M.S. using 0-10V analogue input

Legend E = End user I = Commissioning F = Heating engineer

Navistem settings

BMS 0-10v Power Control

<u>Menu</u>	<u>Operating Line</u>	<u>User Level</u>	<u>Function</u>	<u>Setting</u>
LPB System	6600	F	Device address	1
Configuration	5710	F	Heating circuit 1	Off
	5950	F	Function input H1	Output req VK1 10v
	5951	F	Contact type H1	NO
	5953	F	Voltage value H1	0.1v
	5954	F	Function value 1 H1	200 (200 = 20% modulation)
	5955	F	Voltage value 2 H1	10.0v
	5956	F	Function valve 2 H1	1000 (1000 = 100% modulation)
	5890	F	Relay output QX1	Boiler pump Q1

BMS 0-10v Temperature

<u>Menu</u>	<u>Operating Line</u>	<u>User Level</u>	<u>Function</u>	<u>Setting</u>
LPB System	6600	F	Device address	1
Configuration	5710	F	Heating circuit 1	Off
	5950	F	Function input H1	Consumer req VK1 10v
	5951	F	Contact type H1	NO
	5953	F	Voltage value H1	0.5v
	5954	F	Function value 1 H1	0 (0 = 0°C)
	5955	F	Voltage value 2 H1	10.0v
	5956	F	Function valve 2 H1	800 (800 = 80°C)
	5890	F	Relay output QX1	Boiler pump Q1

Note:

Use H1 wiring connection for 0-10V analog input from B.M.S.

Optional extras required for this configuration:

None

Boiler Parameter Settings: Multiple Boilers With External Merley Boiler Sequence Controller

The maximum number of boiler modules that can be controlled from Merley boiler sequence controller is 16.

The table below shows all available settings up to the heating engineer level. However, certain operating lines may be hidden, for security purposes

Legend E = End user I = Commissioning F = Heating engineer

<u>Menu</u>	<u>Operating Line</u>	<u>User Level</u>	<u>Function</u>	<u>Setting</u>
LPB System	6600	F	Device address	Boiler 1 set to 2 Boiler 2 set to 3 Additional boilers set to 4, 5 ect.
	6601	F	Segment address	Boilers all set to 0
	6640	F	Clock mode	Boilers all set to Slave with remote setting
Configuration	5710	F	Heating Circuit 1	Boilers all set to off
	6200	F	Save sensors	Boilers all yes
	6117	F	Central compensation set up	Boilers all set to 5

Note:

Merley to be set up independently using the Merley O&M (500001210)

Optional extras required for this configuration:

Merley wall mounted boiler sequence controller	Part number 563605672
Merley loose boiler sequence controller for panel mounting	Part number 563605671
LPB bus communication module OC1345—one per boiler module	Part number 563605667

Note:

2x LPB bus communications modules are supplied with each Merley boiler sequence controller, therefore additional modules are only required for boiler module 3 upwards.

USEFUL USER INFORMATION

INSTALLER

SITE ADDRESS

--

--

BOILER TYPE

BOILER SIZE(S)

UNIT NO(S).

SERIAL NO(S).

FLUE

--

--

--

--

--

--

Notes

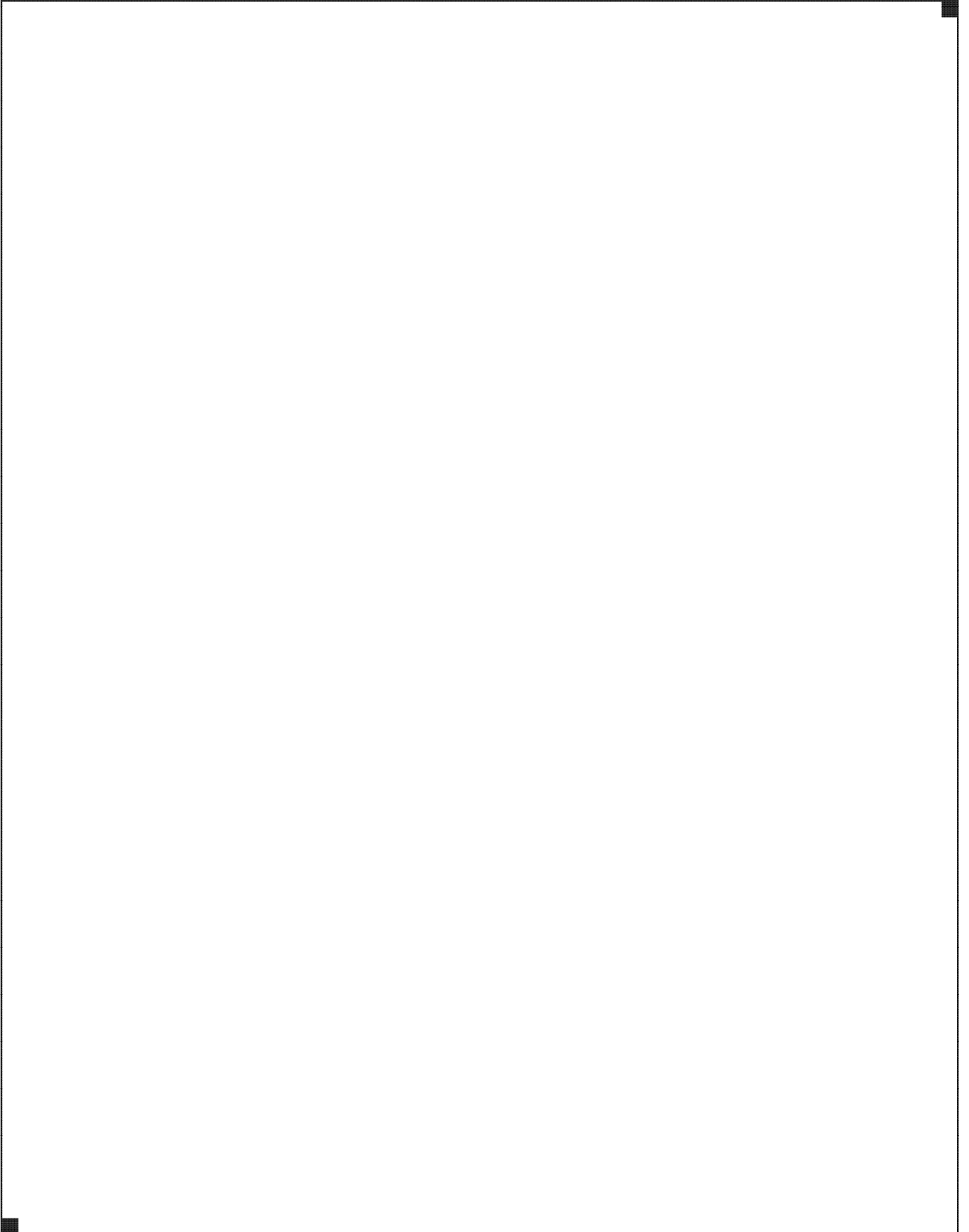

Hamworthy Heating Accredited Agents

North West England (Sales & Service)

Gillies Modular Services
210-218 New Chester Road, Birkenhead, Merseyside L41 9BG
tel: **0151 666 1030** fax: **0151 647 8101**

Southern Ireland (Sales & Service)

HEVAC Limited
Naas Road, Dublin 12, Ireland
tel: **00 353 141 91919** fax: **00 353 145 84806**

Northern Ireland (Sales & Service)

HVAC Supplies Limited
Unit A6, Dargan Court, Dargan Crescent, Belfast BT3 9JP
tel: **02890 747737** fax: **02890 741233**

Scotland (Sales & Service)

McDowall Modular Services
2 Penston Road, Glasgow, Scotland G33 4AG
tel: **0141 336 8795** fax: **0141 771 9635**

North East England (Service)

Allison Heating Products
12 Sunnyside Lane, Cleadon Village, Sunderland SR6 7XB
tel: **0191 536 8833** fax: **0191 536 9933**

Hamworthy Heating Customer Service Centre

Sales

tel: **0845 450 2865**

Technical Enquiries

tel: **0845 450 2865**

Servicing

tel: **01202 662555**

Spares

tel: **0845 450 2866**



Customer Service Centre

Hamworthy Heating Limited,
Fleets Corner, Poole,
Dorset BH17 0HH

Telephone: **0845 450 2866**

Fax: **01202 662522**

Email: **aftersales@hamworthy-heating.com**

Website: **www.hamworthy-heating.com**